

Operating Instructions

Electrically Heated Chamber Furnaces

N ... E(L)(R)
N ... (H)(14)(G)(S)
NW ... (H)

M01.1038 ENGLISCH

Original instructions

■ Made
■ in
■ Germany

www.nabertherm.com

Copyright

© Copyright by
Nabertherm GmbH
Bahnhofstrasse 20
28865 Lilienthal
Federal Republic of Germany

Reg: M01.1038 ENGLISCH
Rev: 2022-09

No responsibility is accepted for the correctness of this information. We reserve the right to make technical alterations.

1	Introduction	6
1.1	Explanation of the Symbols and Warnings	6
1.2	Product Description.....	9
1.3	Overview of the Complete System.....	10
1.4	Key to the Model Names.....	17
1.5	Scope of Delivery.....	17
2	Specifications	19
3	Warranty and Liability	24
4	Safety	24
4.1	Defined Application	24
4.2	Requirements for the Furnace Operator	26
4.3	Protective Clothing.....	27
4.4	Basic Measures During Normal Operation	28
4.5	Basic Measures in Case of Emergency	28
4.6	Basic Measures for Servicing and Maintenance.....	30
4.7	General Risks with the Furnace.....	31
4.8	Safeguarding against Dangers from Excess Temperatures	32
5	Transportation, Installation and Initial Start-Up.....	33
5.1	Delivery.....	33
5.2	Unpacking (N 40 E(R) – N 100 E).....	35
5.3	Unpacking (N 140 E(L) – N 2200(H)(14)(G) – NW 150(H) – NW 300(H)).....	36
5.4	Unpacking (NW 440(H) – NW 2200(H))	37
5.5	Furnace or Switchgear with Transportation Rings (if included)	38
5.6	Transport Securing Device/Packaging	39
6	Constructional and Connection Requirements.....	40
6.1	Installation (Furnace Location)	42
6.1.1	N 40 E(R) – N 100 E.....	42
6.1.2	Stairclimber to Transport Chamber Furnaces N 100(H)(14)(G) – N 300(H)(14)(G) (Accessory)	43
6.1.3	N 100(H)(14)(G) – N 300(H)(14)(G) Installation of the base frame if it is not already installed.....	46
6.1.4	NW 150(H) – NW 300(H)	47
6.1.5	NW 440(H) – NW 660(H) (<u>from</u> model year 2022)	48
6.1.6	NW 440(H) – NW 660(H) (<u>to</u> model year 2022) and NW 1000(H) – NW 2000(H).....	52
6.1.7	Installation Package for Installing the Furnace Framework.....	56
6.1.8	Chemical Anchor Capsule/Anchor Rod Installation Instructions	57
6.1.9	Removing the Transportation Fittings	59
6.1.10	Removing the Foam Mats (NW 440(H) – NW 2200(H)).....	59
6.2	Assembly, Installation, and Connection.....	60
6.2.1	Assembling the Bypass Connection (Depending on Model)	60
6.2.2	Assembling the Air Inlet Flap After Assembling the Frame (N 100(H)(14)(G) – N 300(H)(14)(G)).....	61
6.2.3	Place the Controller in the Holder on the Furnace (model-related)	62
6.2.4	Exhaust Air	62
6.2.4.1	Exhaust Air Control without Ducting	63
6.2.4.2	Exhaust air control with piping	64
6.2.4.3	Installing the Exhaust Hood(s) (Accessories)	68
6.2.4.4	Setting the Height of the Exhaust Hood.....	70

6.2.5	Connecting the Furnace to the Power Supply	70
6.2.6	Initial Start-Up	73
6.2.7	Recommendations for Heating Up the Furnace for the First Time	73
7	Operation	76
7.1	Controller	76
7.2	Operation, Display and Switch Elements (depending on design)	76
7.2.1	Turning on the Controller/Furnace	76
7.2.2	Turning off the Controller/Furnace	77
7.2.3	Accessing Extra Functions (Extra 1 and Extra 2) via the Controller	77
7.2.4	Handling the Controller	79
7.3	Over-Temperature Limiter with Manual Reset and Adjustable Cutout Temperature (Additional Equipment)	80
7.4	Loading/Charging	80
7.5	Driving the Bogie in and out	82
7.6	Opening and Closing the Door	83
7.6.1	Furnace with Adjustable Quick Release	83
7.6.2	Furnace with Quick Release (Variant A)	84
7.6.3	Furnace with Quick Release (Variant B)	84
7.6.3.1	Safety Star Knobs - Actuation with Key (Accessories)	85
7.7	Exhaust-Air Flap (Depending on the Model)	85
7.8	Air Inlet Valve/Flap (Model-Related)	86
7.9	Schematic Description of Fresh Air Supply	88
7.10	Fresh Air and/or Cooling Blower (Additional Equipment)	88
8	Tips for Potters	89
8.1	Bisque Firing	92
8.2	Glaze Firing	92
8.3	Reduction Firing	93
8.4	Preset Programs for Ceramic Applications	93
9	Servicing, Cleaning, and Maintenance	96
9.1	Furnace Insulation	97
9.2	Shutting Down the Furnace for Servicing, Cleaning, and Maintenance	99
9.3	Regular Maintenance Tasks for the Complete System	100
9.4	Regular Maintenance Tasks – Heating Elements/Furnace Chamber	100
9.5	Regular Maintenance Tasks – Heating Elements/Bogie	101
9.6	Regular Maintenance Tasks – Insulation Furnace Chamber	102
9.7	Regular Maintenance Tasks – Insulation Bogie	103
9.8	Regular Maintenance Tasks – Mechanics Bogie	103
9.9	Regular Maintenance Tasks – Housing	103
9.10	Regular Maintenance Tasks – Switchgear	104
9.11	Regular Maintenance Tasks – Electrical Testing	105
9.12	Regular Maintenance Tasks – Documentation	106
9.13	Maintenance Table Key	107
9.14	Cleaning Products	107
10	Malfunctions	108
10.1	Error Messages of the Controller	109
10.2	Warnings of the Controller	111

10.3	Malfunctions of the Switchgear	113
11	Spare Parts/Wearing Parts	114
11.1	Replacing a Heating Element	115
11.1.1	Heating Elements on Support Tubes	116
11.1.2	Heating Elements in Grooves	120
11.2	Replacing a Thermocouple.....	122
11.3	Electrical Schematics/Pneumatic Schematics	122
12	Accessories (Options)	123
12.1	Assembling the Base for Furnace Model N 40 E(R) – N 100 E (Accessory)	123
12.2	Assembling the charging frame (accessory).....	125
12.3	Shelves/Props	126
13	Additional Equipment.....	127
13.1	Operation with Heat Treatment Accessories	127
14	Nabertherm Service.....	129
15	Declaration of Conformity	130
16	For Your Notes	131

1 Introduction

These documents are intended only for buyers of our products and may not be copied or disclosed to third parties without our written consent. (Law governing copyright and associated protective rights, German Copyright Law from Sept. 9, 1965)

Nabertherm GmbH owns all rights to drawings, other documents and authorizations, also in case of applications for protective rights.

All the figures in the instructions have a descriptive character; in other words, they do not represent the exact details of the furnace.

1.1 Explanation of the Symbols and Warnings



Note

In the following operating instructions, specific warnings are given to draw attention to residual risks that cannot be avoided when the furnace is operating. These residual risks include dangers for humans/products/ the furnace, and the environment.

The symbols used in the operating instructions are especially intended to draw attention to safety information.

The symbols used cannot replace the text of the safety information. Therefore, always read the entire text.

Graphic symbols correspond to **ISO 3864**. In accordance with the **American National Standard Institute (ANSI) Z535.6** the following warning information and words are used in this document:



The general hazard symbol, in combination with the words **CAUTION**, **WARNING** and **DANGER** warns about the risk of serious injury. Observe the following information to prevent injury or death.

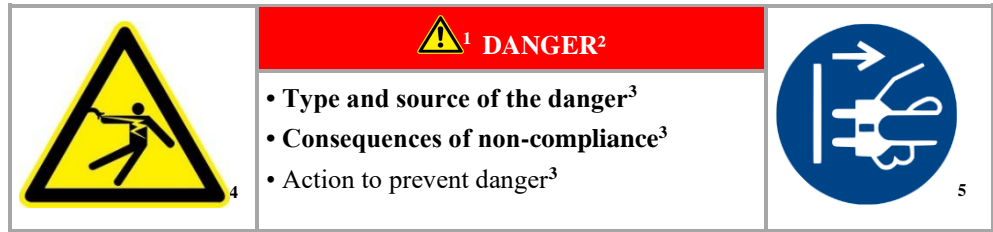
NOTE	Refers to a hazard that could damage or destroy the equipment.
CAUTION	Refers to a hazard with a minor or medium risk of injury.
WARNING	Refers to a hazard that could cause death, serious or irreversible injury.
DANGER	Refers to a hazard that could directly cause death, serious or irreversible injury.

Structure of the Warning:

All Warnings are Structured as Follows

	¹ WARNING ²
4	<ul style="list-style-type: none"> • Type and source of the danger³ • Consequences of non-compliance³ • Action to prevent danger³

or



Position	Description	Explanation
1	Hazard Symbol	Indicates the risk of injury
2	Signal Word	Classifies the danger
3	Reference Texts	<ul style="list-style-type: none"> Type and source of the danger Possible consequences of non-compliance Measures/prohibitions
4	Graphical Symbols (optional) According to ISO 3864	Consequences, measures, and prohibitions
5	Graphical Symbols (optional) According to ISO 3864	Instructions or prohibitions

Information Symbols in the Instructions:



Note

Below this symbol you will find instructions and particularly useful information.



Rule - Rule Sign

This symbol draws attention to important rules that must be observed. Rule signs protect people against injury and show what is to be done in certain situations.



Rule – Important Information for Operators

This symbol draws the operator's attention to important information and operating instructions that must be observed.



Rule – Important Information for Maintenance Personnel

This symbol draws the maintenance personnel's attention to important operating and maintenance instructions (service) that must be observed.



Rule – Pull Out the Power Plug

This symbol tells the operator to pull out the power plug.



Rule – Lift only with Several People

This symbol draws the personnel's attention to the fact that this device may only be lifted and moved to its final destination by several people.



Warning – Hot Surface, Do Not Touch

This symbol warns the operator that the surface is hot and should not be touched.



Warning – Danger of Electric Shock

This symbol warns the operator that there is a risk of an electric shock if the following warnings are not heeded.



Warning – Danger if Heavy Loads are Lifted

This symbol warns the operator of the potential dangers of lifting heavy loads. Ignoring this can lead to injury.



Caution – Danger of Falling

Ignoring this can lead to fatal injury. Danger of falling exists at a height less than 1.00 m above the ground or another sufficiently broad bearing surface (for example, on elevated operating positions and workplaces, working platforms, galleries, platforms, footbridges, flying bridges, ramps and stairways), openings and recesses through which people can fall (for example in floors, platforms, installation openings, hatchways and pits, non-bearing roofs).



Warning – Fire Danger

This symbol warns operators of the danger of fire if the following information is not followed.



Prohibited – Important Information for Operators

This symbol warns the operator that water or cleaning products must NOT be poured over the objects. A high-pressure cleaning device must also not be used.



Prohibited – Important information for operators

This symbol warns the operator that the surface must NOT be walked upon. There is a risk of it caving in or components could break or be damaged if they are walked upon.

Warning Signs on the Furnace:



Warning – Hot Surface, Danger of Burning – Do Not Touch

You may not always realize that surfaces, such as furnace components, furnace walls, doors and materials, and even liquids are hot. Do not touch the surface.



Warning – Danger of Electric Shock!

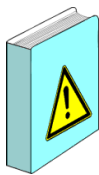
Warning, dangerous electric voltage



! DANGER

- **It is not allowed to walk on the furnace roof.**
- **There is a risk of it caving in.**
- Components can break or be damaged if they are walked upon.

1.2 Product Description



These electrically heated furnaces are a high-quality product which will give you many years of reliable service if they are properly cared for and maintained. One basic prerequisite is that the furnace is used the way it was designed to be used.

During development and production a high priority was placed on safety, functionality and economy.

Furnaces in this model series are electrically heated firing furnaces for ceramic, glass or porcelain paintings, but can also be used for simply fusing jobs. This furnace model features an attractive design, highest quality and an excellent temperature uniformity. Ceramic furnaces are, depending on the furnace model, heated from both sides, three sides or five sides. The right furnaces for hobby, schools, nursery schools, studios as well as small workshops.

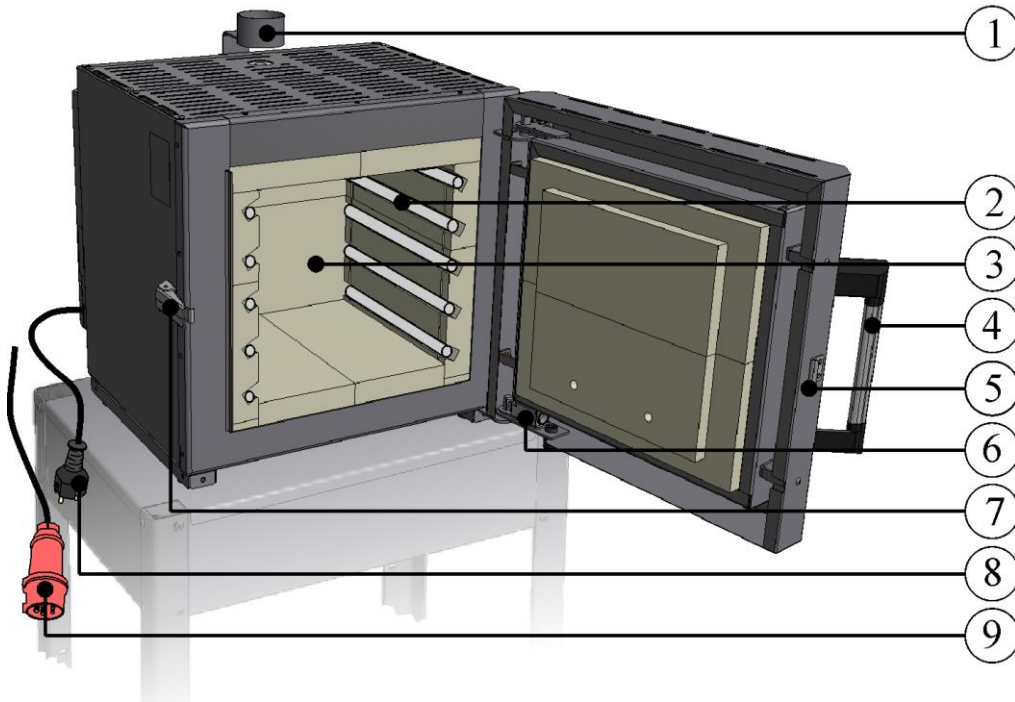
Description of the Furnace

Basic Construction:

- Professional design
- Rugged housing design
- Environment-friendly, long-life powder-coating of housing
- Dual shell door with low outside temperatures
- Multi-layered lining with light weight insulation bricks and microporous insulation for a cooler shell and low power consumption
- Air outlet in the ceiling
- Thermocouple Type S
- High quality heating wire with optimal thickness and length results in long life time
- Special arrangement of the heating elements for optimal temperature uniformity
- Solid state relays provide for low-noise operation
- Fast power switching for precise temperature uniformity
- Door safety switch shuts down power to the elements when the door is opened
- NTLog Basic for Nabertherm controller: recording of process data with USB-flash drive
- Exclusive use of insulation materials without categorization according to EC Regulation No 1272/2008 (CLP). This explicitly means that alumino silicate wool, also known as “refractory ceramic fiber” (RCF), which is classified and possibly carcinogenic, is not used.

1.3 Overview of the Complete System

Furnace model N 40 E(R) – N 500 E (similar to picture)

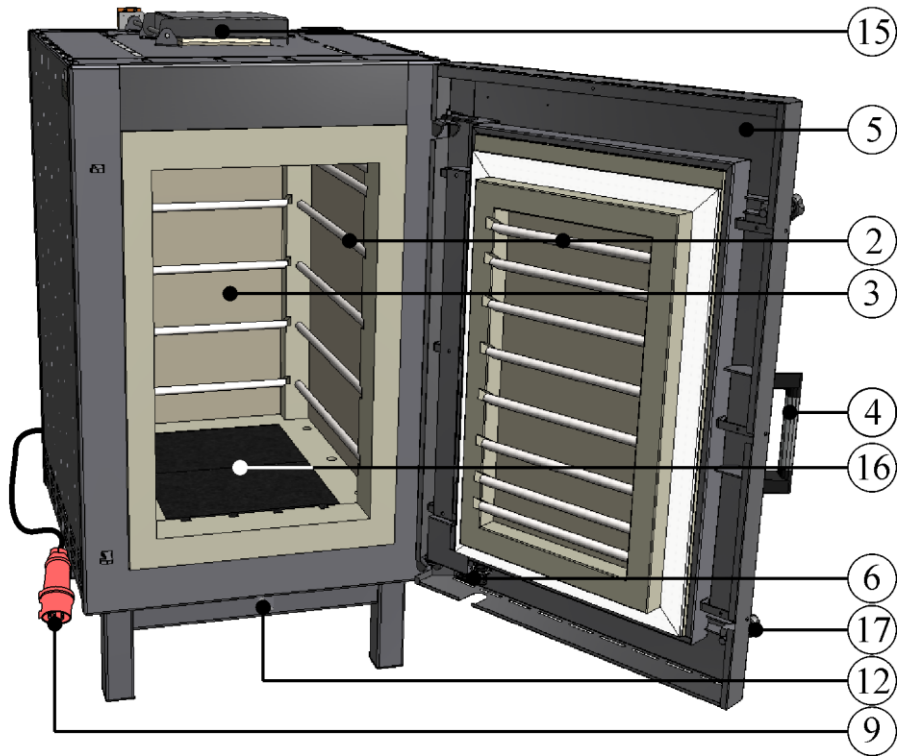


Chamber furnace as tabletop model (table not included with delivery)

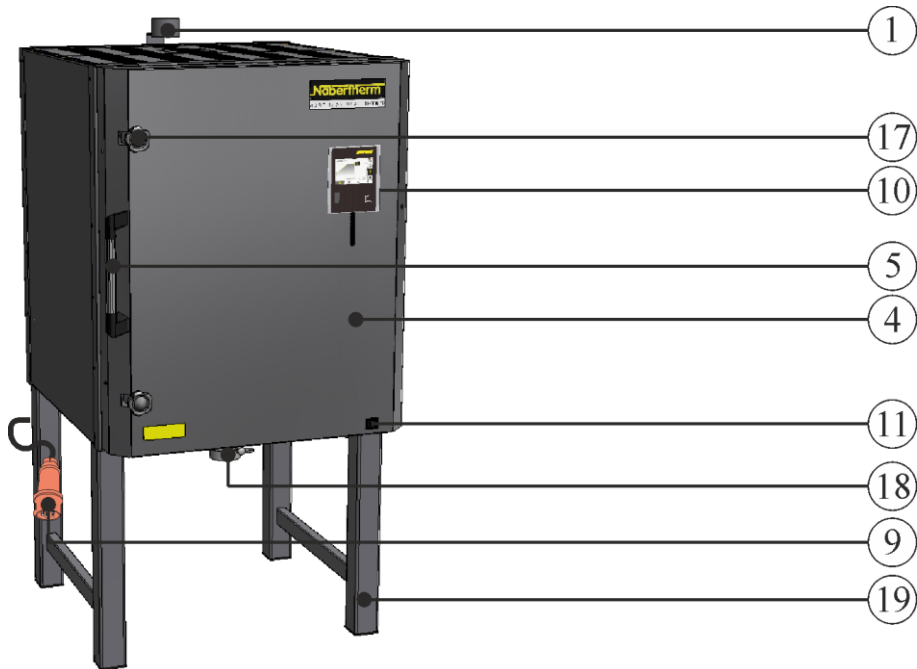


Fig. 1: Example: Chamber furnace N 40 E (tabletop model) with frame and castors as accessories

Furnace model N 100(H)(14)(G) – N 2200(H)(14)(G) (similar to picture)



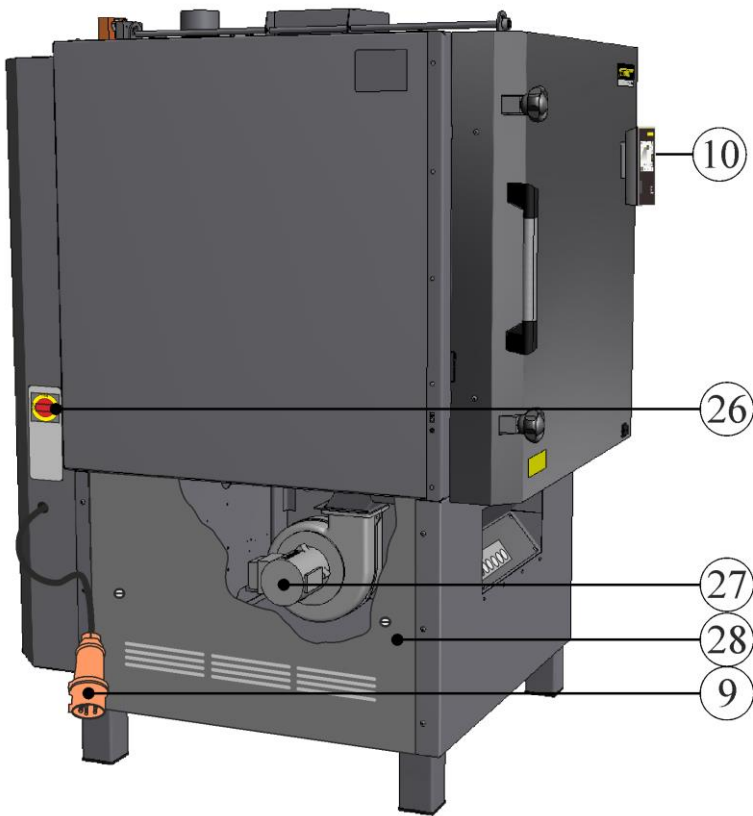
Example N 440/H



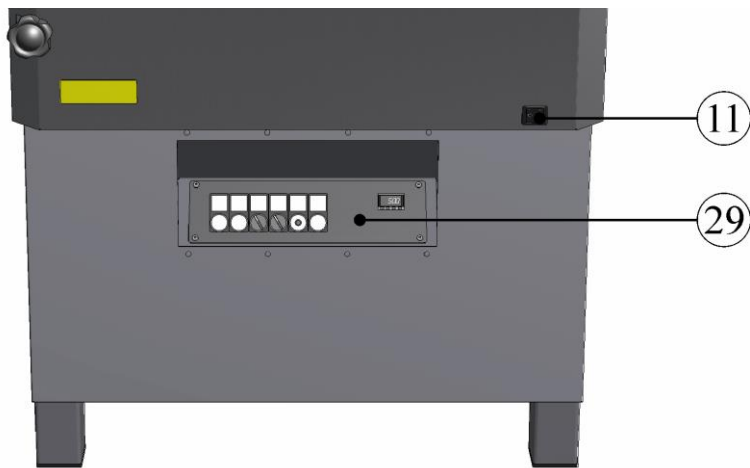
Example N 150/H

Fig. 2: Example: Chamber furnace N 440/H and N 150/H

Furnace model from a current of 32 A (similar to picture)



Example: Chamber furnace with main switch from 32 A current



Example: Enclosed frame in combination with cooling fan

Fig. 3: Example: Chamber furnace N 100(H)(14)(G) to N 300(H)(14)(G)

Furnace model NW 150(H) – NW 300(H) (similar to picture)

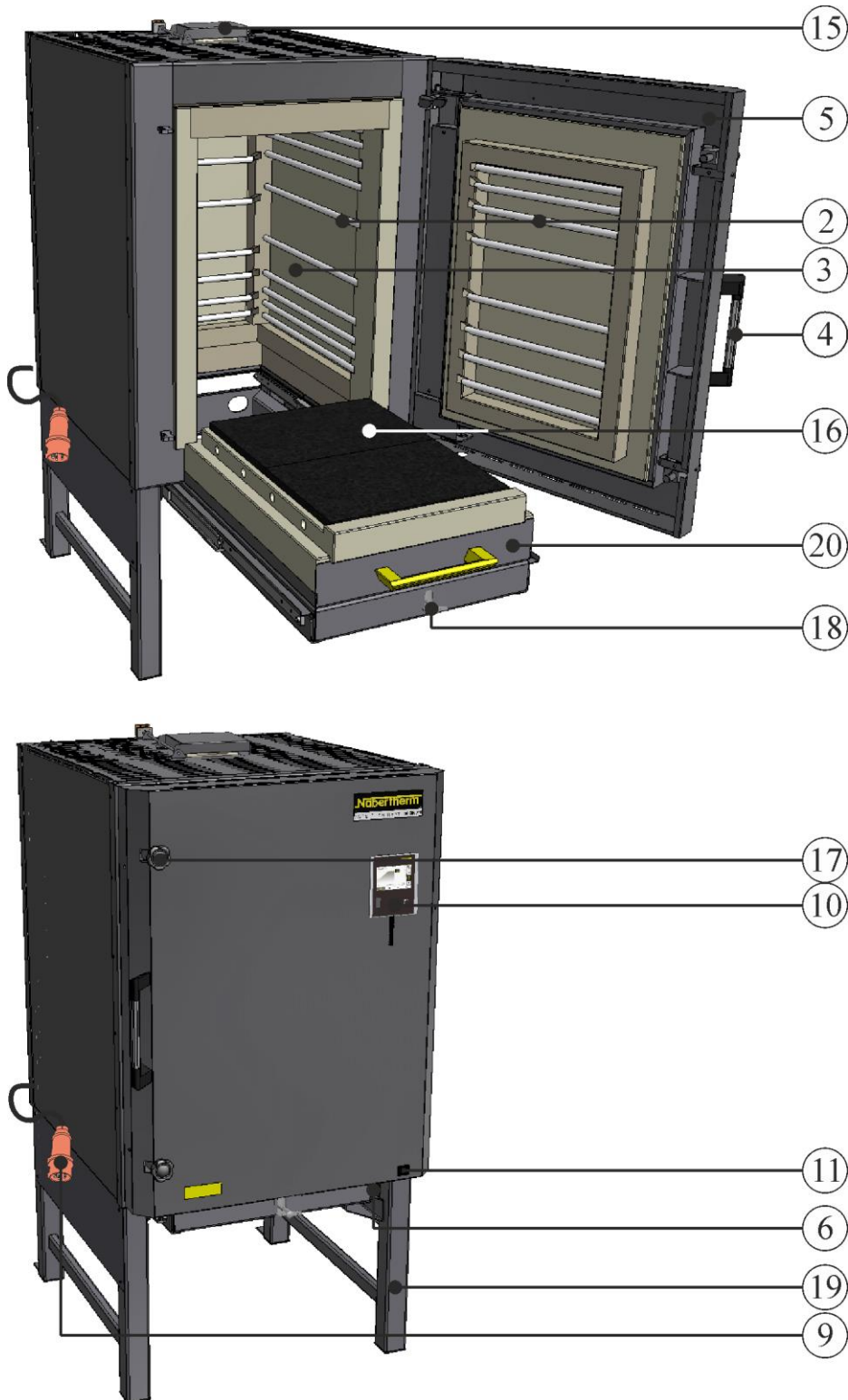
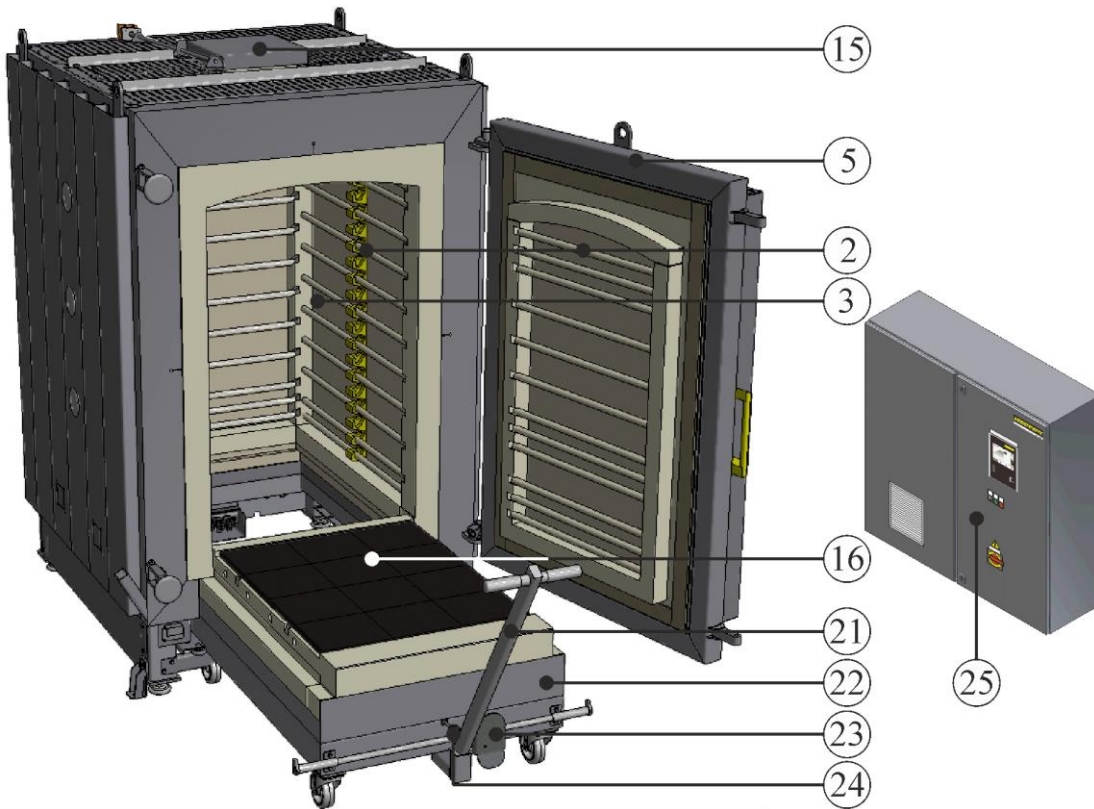
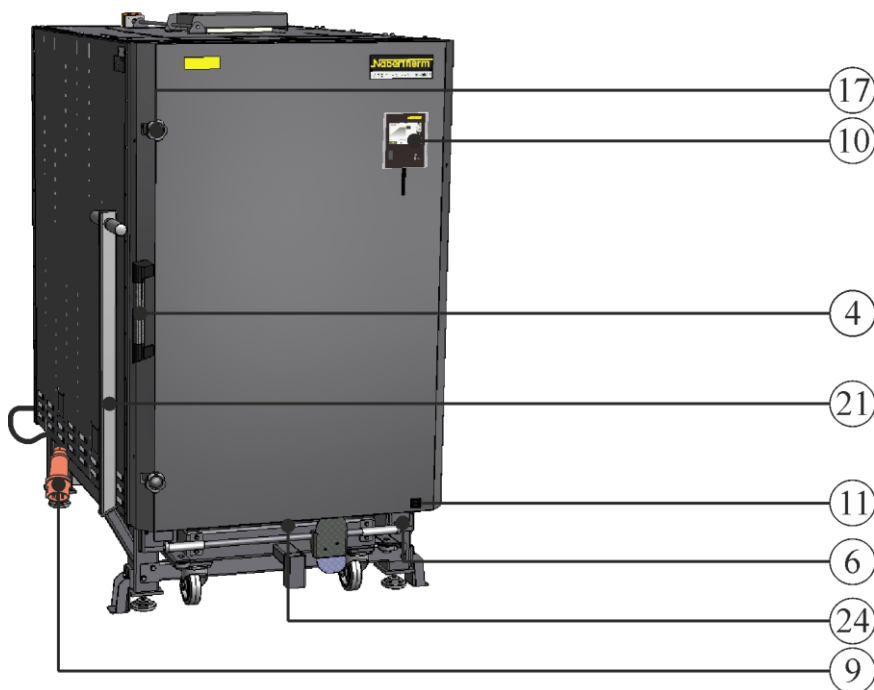


Fig. 4: Example: Chamber furnace NW 300 with pull-out drawer

Furnace model NW 440(H) bis NW 1000(H) (similar to picture)



NW 1000 with external switchgear (controller and switching elements depending on model)

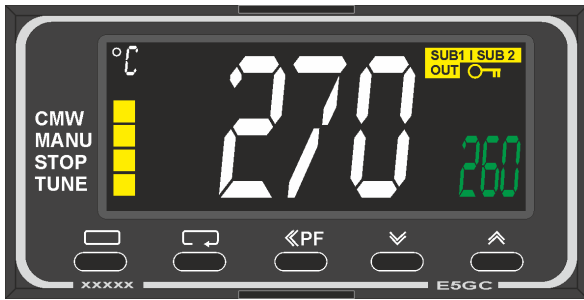


NW 660

Fig. 5: Example: Chamber furnace with removable bogie

No.	Name
1	Bypass connection
2	Heating elements on support tubes
3	Furnace chamber
4	Handle
5	Swing door
6	Door contact switch
7	Adjustable door lock
8	Power plug (up to 3600 watts)
9	Power plug (from 5500 watts)
10	Controller (depending on design)
11	Protective device switch with integrated fuse (for switching furnace on/off)
12	Fresh-air inlet (infinitely adjustable)
13	Base (accessory): convenient filling height of 770 mm (without transport casters)
14	Transport casters as accessories (front casters with locking brake)
15	Automatic exhaust air flap (N 100(H)(14)(G)-N 300(H)(14)(G) as additional equipment; standard from N 440(H)(14)(G))
16	SiC floor tile to protect the bottom heating
17	Lock
18	Semi-automatic, electromagnetically controlled air inlet flap (fully automatic as additional equipment)
19	Base frame
20	Pull-out drawer (to pull out the furnace floor for easy charging. NW 150(H)(G) – NW 300(H)(G); from NW 440(H) the furnace floor is designed as a bogie)
21	Draw bar
22	Bogie can be moved freely, with internal heating elements
23	Foot pedal (for easy locking of the bogie and furnace housing)
24	Infinitely adjustable, manual fresh-air opening
25	Switchgear (controller and switching elements depending on model)
26	Main switch (depending on model)
27	Cooling fan (accessory)
28	Closed base with removable side panels (only in combination with a cooling fan)
29	Operating, display, and switching elements (depending on design)

Additional Equipment

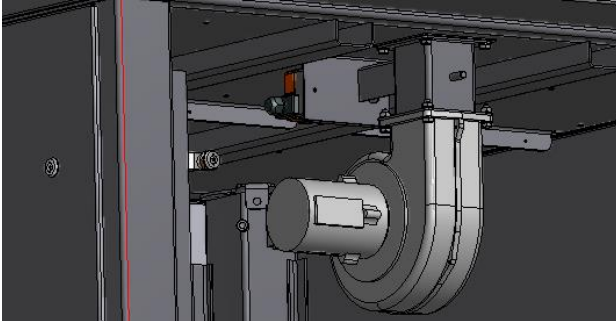


Over-temperature limiter with manual reset according to DIN EN IEC 60519-1 as over-temperature protection for the furnace and the charge

Abb. 6: Beispiel (Abbildung ähnlich)



Gas supply system for non-flammable protective and reaction gases with shut-off valve and flow meter with control valve, piped and ready to connect (similar to picture)



Controlled or uncontrolled cooling system with frequency-controlled cooling blower (similar to picture)

Accessories



Stainless steel exhaust hood (similar to picture)

Height adjustable via the screws on the bracke

1.4 Key to the Model Names

Example	Explanation
N 70 E/R	N = Chamber furnace NW = Chamber furnace with drawer mechanism or bogie system
N 70 E/R	40 = 40-liter furnace chamber (volume in L) 70 = 70-liter furnace chamber (volume in L) 100 = 100-liter furnace chamber (volume in L) 140 = 140-liter furnace chamber (volume in L) ... 1000 = 1000-liter furnace chamber (volume in L) 1500 = 1500-liter furnace chamber (volume in L) 2200 = 2200-liter furnace chamber (volume in L)
N 70 E/R	E = entry model H = high temperature 14 = 1400 °C G = 900 °C LE = low energy R = rapid S = special design













 MORE THAN HEAT 30-3000 °C		
Nabertherm GmbH Bahnhofstr. 20, 28865 Lilienthal/Bremen, Germany Tel +49 (04298) 922-0, Fax +49 (04298) 922-129 contact@nabertherm.de www.nabertherm.com		
Made in Germany		
N 70 E/R	SN 123456	2021
NE02R2N-NE	1300 °C	 5,5 kW
-	400 V 3/N/PE~	-
50 Hz	13,8/0,0/13,8 A	5,5 kW
		





Fig. 7: Example: Model name (type plate)


1.5 Scope of Delivery

The scope of delivery includes:

	System components	Quantity	Comment
	Chamber furnace	1 x	Nabertherm GmbH
	Power cable ¹	1 x	Nabertherm GmbH
	Bypass connection ¹	1 x	Nabertherm GmbH
	Air inlet flap ¹	1 x	Nabertherm GmbH

	System components	Quantity	Comment
	SiC floor tile ¹ (furnace models N 100(H)(14)(G) – NW 1000(H))	3	Nabertherm GmbH
	Allen key	1 x	Nabertherm GmbH
	Tile ¹ 691600956 (furnace model N 40 E(R) – N 280 E)	3 x	Nabertherm GmbH
	Prop ¹ 691600185 (furnace model N 140 LE – N 280 E)	3 x	Nabertherm GmbH

Accessories:			
	Frame ²	1 x	Nabertherm GmbH
	Castor ²	4 x	Nabertherm GmbH
	Shelves/Props ²	4	Nabertherm GmbH
	Charging frame ²	1x ²	Nabertherm GmbH
	Pallet truck ²	1x ²	Nabertherm GmbH
	Other components, depending on model	- - -	See shipping documents

	Document type	Quantity	Comment
	Furnace operating instructions	1 x	Nabertherm GmbH
	Controller operating instructions	1 x	Nabertherm GmbH
	Other documents, depending on model	- - -	

¹ included with delivery depending on design/furnace model

² included with delivery if required, see shipping documents

³ quantity depends on furnace model

⁴ quantity as required, see shipping documents



Note

Keep all documents for future reference. All functions of this furnace system were tested during manufacturing and prior to shipping.



Note

The documents included do not always contain the electrical schematics and pneumatic diagrams.

If you need the respective diagrams, they can be ordered from Nabertherm Service.

2 Specifications



Electrical specifications are on the type plate located on the side of the furnace.

Model	Tmax	Inner dimensions in mm			Volume	Outer dimensions in mm			Connecte d load	Electrical connectio n	Weigh t
	°C	w	d	h	in L	W	D	H			
N 40 E	1300	350	330	350	40	640	800	600 ²	2.9	1-phase	95
N 40 E/R	1300	350	330	350	40	640	800	600 ²	5.5	3-phase ¹	95
N 70 LE	1200	400	380	450	70	690	850	700 ²	2.9	1-phase	120
N 70 E	1300	400	380	450	70	690	850	700 ²	3.6	1-phase	120
N 70 E/R	1300	400	380	450	70	690	850	700 ²	5.5	3-phase ¹	120
N 100 LE	1100	460	440	500	100	750	910	750 ²	5.5	3-phase	150

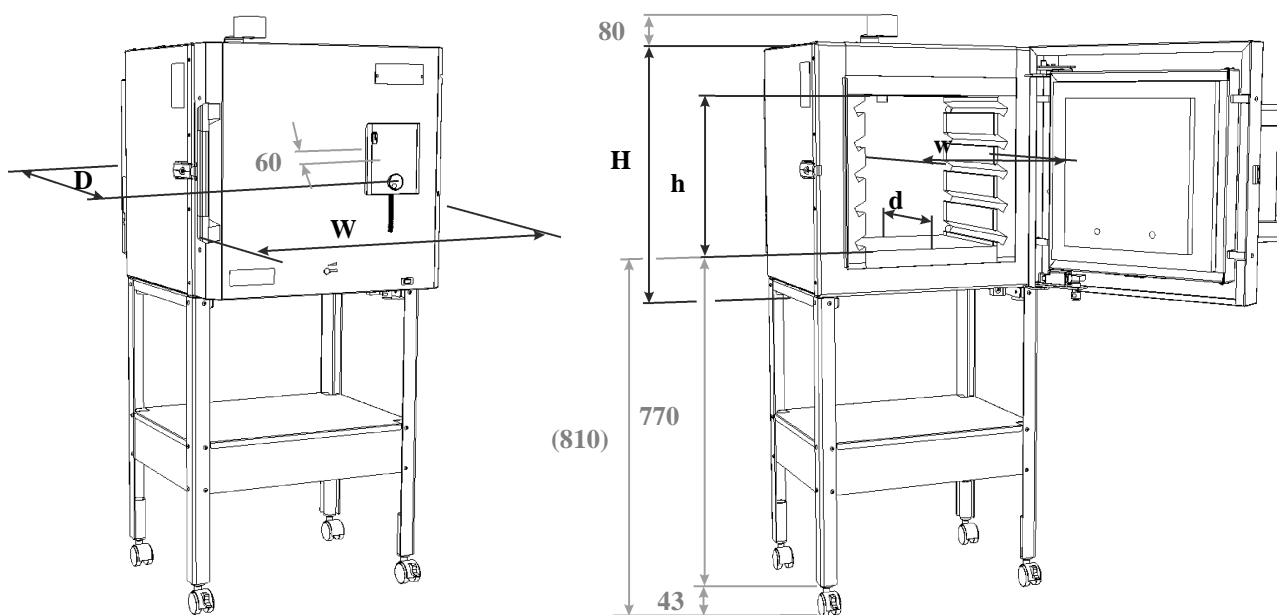
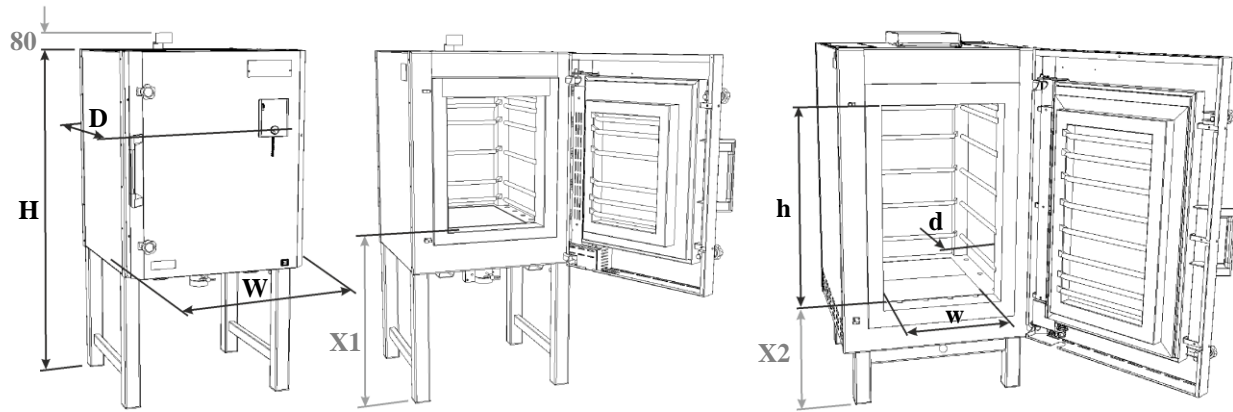


Fig. 8: Dimensions N 40 E(R) – N 100 E(LE)

Model	Tmax	Inner dimensions in mm			Volume	Outer dimensions in mm			Connecte d load	Electrical connectio n	Weigh t
	°C	w	d	h	in L	W	D	H			
N 140 LE	1100	450 ⁵	580	570 ⁶	140	720	1130	1440 ³	6.0	3-phase ¹	280
N 210 LE	1100	500 ⁵	580	700 ⁶	210	770	1130	1570 ³	9.0	3-phase	320
N 280 LE	1100	520 ⁵	580	890 ⁶	280	790	1130	1760 ³	9.0	3-phase	400
N 140 E	1300	450 ⁵	580	570 ⁶	140	720	1130	1440 ³	9.0	3-phase	280

Model	Tmax	Inner dimensions in mm			Volume	Outer dimensions in mm			Connect d load	Electrical connectio n	Weigh t
N 210 E	1300	500 ⁵	580	700 ⁶	210	770	1130	1570 ³	11.0	3-phase	320
N 280 E	1300	520 ⁵	580	890 ⁶	280	790	1130	1760 ³	15.0	3-phase	400
N 500 E	1300	600 ⁵	820	1000 ⁶	500	1000	1410	1830 ³	30.0	3-phase	760



X1 = 780 mm X2 = 500 mm N 440 (G)(H)(14) - N 660 (G)(H)(14)

Fig. 9: Dimensions N 140 E(LE) – N 660 (G)(H)(14)

Model	Tmax	Inner dimensions in mm			Volume	Outer dimensions in mm			Connect d load	Electrical connectio n	Weigh t
	°C	w	d	h	in L	W	D	H	kW		in kg
N 100/G	900	400	530	460	100	710	1130	1440	7.0	3-phase	280
N 150/G	900	450	530	590	150	760	1130	1570	9.0	3-phase	330
N 200/G	900	470	530	780	200	790	1130	1760	11.0	3-phase	380
N 200/GS	900	400	1000	500	200	795	1670	1550	16.0	3-phase	500
N 250/GS	900	500	1000	500	250	895	1670	1550	18.0	3-phase	660
N 300/G	900	550	700	780	300	860	1300	1760	15.0	3-phase	450
N 360/GS	900	600	1000	600	360	995	1670	1705	20.0	3-phase	810
N 440/G	900	600	750	1000	450	1000	1410	1830	20.0	3-phase	820
N 500/Gs	900	600	1400	600	500	995	2070	1705	22.0	3-phase	1000
N 660/G	900	600	1100	1000	660	1000	1750	1830	26.0	3-phase	950
N 1000/G	900	800	1000	1250	1000	1390	1850	2140	40.0	3-phase	1680
N 1500/G	900	900	1200	4000	1500	1590	2050	229	57.0	3-phase	2300
N 2200/G	900	1000	1400	1600	2200	1690	2050	2490	75.0	3-phase	2800

N 100	1300	400	530	460	100	710	1130	1440	9.0	3-phase	280
N 150	1300	450	530	590	150	760	1130	1570	11.0	3-phase	330
N 200	1300	470	530	780	200	790	1130	1760	15.0	3-phase	380
N 200/S	1300	400	1000	500	200	795	1670	1550	18.0	3-phase	500
N 250/S	1300	500	1000	500	250	895	1670	1550	20.0	3-phase	660
N 300	1300	550	700	780	300	860	1300	1760	20.0	3-phase	450
N 360/S	1300	600	1000	600	360	995	1670	1705	22.0	3-phase	810
N 440	1300	600	750	1000	450	1000	1410	1830	30.0	3-phase	820
N 500/S	1300	600	1400	600	500	995	2070	1705	24.0	3-phase	1000
N 660	1300	600	1100	1000	660	1000	1570	1830	40.0	3-phase	950
N 1000	1300	800	1000	1250	1000	1390	1850	2140	57.0	3-phase	1800
N 1500	1300	900	1200	1400	1500	1590	2050	2290	75.0	3-phase	2500
N 2200	1300	1000	1400	1600	2200	1690	2250	2490	110.0	3-phase	3100

N 100/H	1340	400	530	460	100	760	1150	1440	11.0	3-phase	330
N 150/H	1340	430	530	620	150	790	1150	1600	15.0	3-phase	380
N 200/H	1340	500	530	720	200	860	1150	1700	20.0	3-phase	430
N 300/H	1340	550	700	780	300	910	1320	1760	27.0	3-phase	540
N 440/H	1340	600	750	1000	450	1000	1410	1830	40.0	3-phase	900
N 660/H	1340	600	1100	1000	660	1000	1750	1830	52.0	3-phase	1250
N 1000/H	1340	800	1000	1250	1000	1390	1850	2140	745.0	3-phase	2320
N 1500/H	1340	900	1200	1400	1500	1590	2050	2290	110.0	3-phase	2700
N 2200/H	1340	1000	1400	1600	2200	1690	2250	2490	140.0	3-phase	3600

N 100/14	1400	400	530	460	100	760	1150	1440 ³	15.0	3-phase	370
N 150/14	1400	430	530	620	150	790	1150	1600 ³	20.0	3-phase	400
N 200/14	1400	500	530	720	200	860	1150	1700 ³	22.0	3-phase	490
N 300/14	1400	550	700	780	300	910	1320	1760 ³	30.0	3-phase	620
N 440/14	1400	600	750	1000	450	1000	1410	1830 ³	40.0	3-phase	1150
N 660/14	1400	600	1100	1000	660	1000	1750	1830 ³	57.0	3-phase	1400
N 1000/14	1400	800	1000	1250	1000	1390	1850	2140 ³	75.0	3-phase	250
N 1500/14	1400	900	1200	1400	1500	1590	2050	2290 ³	110.0	3-phase	3000
N 2200/14	1400	1000	1400	1600	2200	1690	2250	2490 ³	140.0	3-phase	3900

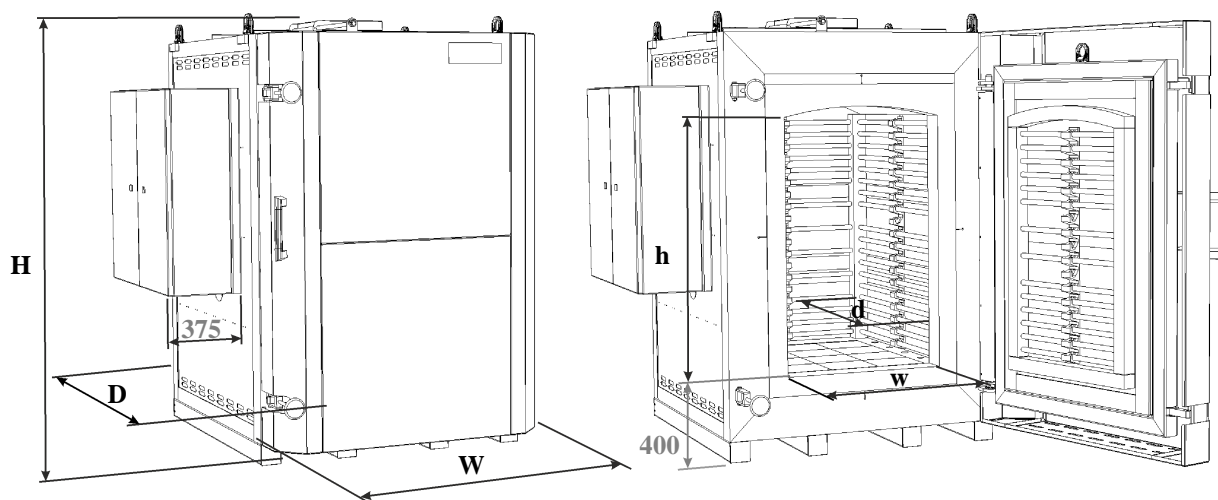
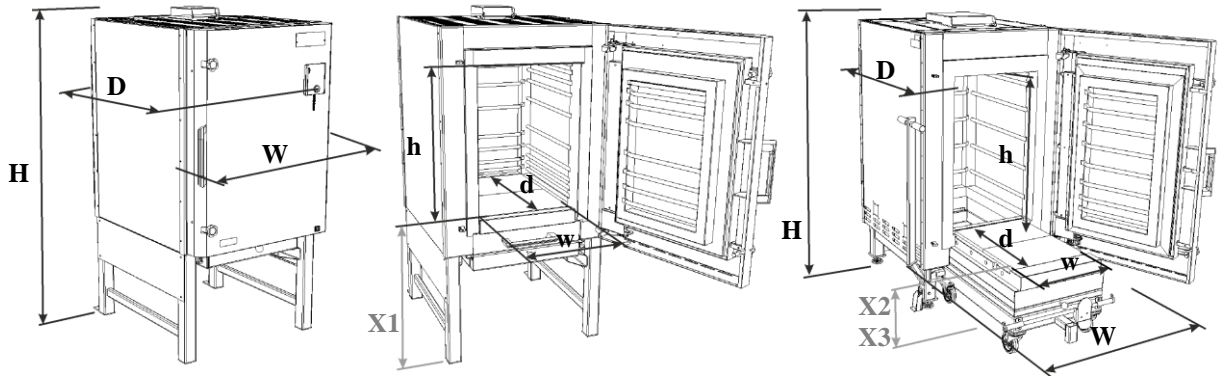


Fig. 10: Dimensions N 1000(G)(H)(14) - N 2200(G)(H)(14)

Model	Tmax	Inner dimensions in mm			Volume	Outer dimensions in mm			Connect d load	Electrical connection	Weigh t
	°C	w	d	h	in L	W	D	H			
N 150	1300	430	530	620	150	790	1150	1600	11.0	3-phase	420
N 200	1300	500	530	720	200	860	1150	1700	15.0	3-phase	490
N 300	1300	550	700	780	300	910	1320	1760	20.0	3-phase	590
N 440	1300	600	750	1000	450	1070	1410	1830	30.0	3-phase	850
N 660	1300	600	1100	1000	660	1070	1750	1830	40.0	3-phase	1180
N 1100	1300	800	1000	1250	1000	1460	1760	2230	57.0	3-phase	2100
N 1500	1300	900	1200	1400	1500	1560	1960	2370	75.0	3-phase	2500
N 2200	1300	1000	1400	1600	2200	1720	2160	2590	110.0	3-phase	3100

NW 150/H	1340	430	530	620	150	790	1150	1600	15.0	3-phase	520
NW 200/H	1340	500	530	720	200	860	1150	1700	20.0	3-phase	590
NW 300/H	1340	550	700	780	300	910	1320	1760	27.0	3-phase	670
NW 440/H	1340	600	750	1000	450	1070	1410	1830	40.0	3-phase	940
NW 660/H	1340	600	1100	1000	660	1070	1750	1830	57.0	3-phase	1310
NW 1000/H	1340	800	1000	1250	1000	1470	1750	2220	75.0	3-phase	2700
NW 1500/H	1340	900	1200	1400	1500	1560	1960	2370	110.0	3-phase	2700
NW 2200/H	1340	1000	1400	1600	2200	1720	2160	2590	140.0	3-phase	3300

Note Model **NW 150** with pull-out drawer – maximum charge weight **75 kg**
 Model **NW 200** with pull-out drawer – maximum charge weight **100 kg**
 Model **NW 300** with pull-out drawer – maximum charge weight **150 kg**



X1 = 790 mm NW 150 (H) - NW 300 (H)
 X3 = 540 mm NW 1000 (H)

X2 = 500 mm NW 440 (H) - NW 660 (H)

Fig. 11: Dimensions NW 150(H) - NW 2200(H)

- ¹ Heating only between two phases
- ² Height with frame +632 mm
- ³ Including frame
- ⁴ Protection with connection to 230 V = 32 A
- ⁵ Collar width 50 mm reduced
- ⁶ Collar height 110 mm reduced
- ⁷ Fresh-air fan +600 mm
- ⁸ Flue +525 mm

Electrical Connection	Voltage (V):	Consult type plate
	Frequency (Hz):	Consult type plate
	Electric current (A):	Consult type plate
Thermal Protection Class	Furnaces:	EN IEC 60519-1
Protective Type	Furnaces:	IP20
	Switch cabinet:	IP40
Ambient Conditions for Electrical Equipment	Temperature:	+5 °C to + 40 °C
	Humidity:	max. 80 % not condensing
Weights	Furnace with accessories	Varies (consult the shipping papers)
Emissions	Continuous sound pressure level	< 70 dB(A)

3 Warranty and Liability



As regards warranty and liability, the normal Nabertherm warranty terms apply, unless individual terms and conditions have been agreed. However, the following conditions also apply:

Warranty and liability claims for personal injury or damage to property shall be excluded if they are attributable to one or more of the following causes:

- All persons involved in operation, installation, maintenance, or repair of the furnace must have read and understood the operating instructions. No liability will be accepted for damage or disruption to operation resulting from non-compliance with the operating instructions.
- Not using the furnace as intended
- Improper installation, start-up, operation, or maintenance of the furnace,
- Operation of the furnace with defective safety equipment or improperly installed or non-functioning safety and protective equipment
- Not observing the information in the operating instructions with respect to transportation, storage, installation, start-up, operation, maintenance, or equipping the furnace
- Making unauthorized changes to the furnace
- Making unauthorized changes to the operating parameters
- Making unauthorized changes to the parameterization, the settings, or the program
- Nabertherm accepts absolutely no liability for damage caused by using parts that are not original Nabertherm parts. Original parts and accessories are designed especially for Nabertherm furnaces. Replace parts only with original Nabertherm parts. Otherwise the warranty will be void.
- Catastrophes due to third-party causes and force majeure

4 Safety

4.1 Defined Application



The Nabertherm furnace was designed and built in conformance with a careful selection of the applicable harmonized standards and other technical specifications. Hence, it corresponds to the state of the art and assures the greatest degree of safety.

Furnaces in this model series are electrically heated firing furnaces for ceramic, glass or porcelain paintings, but can also be used for simply fusing jobs.

Improper furnace operation:

- Any other use, such as processing of products other than those for which the furnace was intended as well as handling hazardous materials or materials dangerous to health is deemed IMPROPER.
- The set-up instructions and safety regulations must be followed, otherwise the furnace will be considered improperly used, effectively cancelling any claims against Nabertherm GmbH. The EC Declaration of Conformity will cease to be valid if any modifications are made to the machine without our approval.
- The set-up instructions and safety regulations must be followed, otherwise the furnace will be considered improperly used, effectively cancelling any claims against Nabertherm GmbH.

Target group

The instructions are intended for operators and qualified specialists. Persons who work with the furnace system should pay special attention. Only people with the necessary training or who have received the necessary instructions may work with the furnace.

In accordance with EN 60335-1, the following standards apply

This furnace may be used by children aged 8 years and above and by persons with reduced physical, sensory or mental capabilities or lack of experience and knowledge, provided they are supervised or have received instructions in using the furnace safely and they understand the hazards involved. Children must not be allowed to play with the furnace.



Operation with power sources, products, operating equipment, auxiliary materials, etc., which are listed as hazardous or which may in any way harm the health of the operator is prohibited.

The furnace must not be filled with materials or substances that release explosive gases or vapors. Only materials and substances whose properties are known may be used.



This furnace was designed for **private and commercial** use. The furnace is **NOT** to be used for heating food, animals, wood, grains, etc.

The furnace must **NOT** be used to heat the workplace.

Do **NOT** use the furnace to melt ice or for similar purposes.

Do **NOT** use the furnace as a clothes dryer.



Note

See safety instructions in the individual sections.

The operator is liable for any resulting damages.

- The furnace may only be operated in the manner described in these operating instructions, i.e., the operating instructions must be completely read and understood.
- The set-up instructions and safety regulations must be followed, otherwise the furnace will be considered improperly used, effectively cancelling any claims against Nabertherm GmbH.
- Under certain circumstances gases or materials may be released from the materials in the furnaces that settle on the insulation or the heating elements and destroy them. **If applicable, read the labels and instructions on the packaging of materials that you use.**
- Furnaces with over-temperature limit controllers must have their shut-down temperatures set to prevent any overheating of the material.
- Opening the furnace while it is still hot, over 200 °C (392 °F), can lead to increased wear of the following components: insulation, door seal, heating elements and furnace housing. No liability shall be accepted for any damage to the goods or the furnace resulting from non-compliance with this warning.



This furnace was designed for **private and commercial** use. The furnace is **NOT** to be used for heating food, animals, wood, grains, etc.

The furnace must **NOT** be used to heat the workplace.

Do **NOT** use the furnace to melt ice or for similar purposes.

Do **NOT** use the furnace as a clothes dryer.



Note

See safety instructions in the individual sections.



For all furnace systems

Operation with explosive gases or mixtures or explosive gases or mixtures formed during the process is prohibited.

These furnace systems have no safety technology for processes in which combustible mixtures can form (design does not meet the safety requirements of EN 1539)

The concentration of organic gases must at no time exceed 3% of the lower explosion limit (LEL) in the furnace. This requirement not only applies to normal operation, but also in particular to exceptional circumstances, such as process malfunctions (due to the breakdown of a unit, etc.).

Nabertherm offers a wide range of furnaces that have been especially developed for processes with combustible gases.



Note

This product does not comply with the ATEX Directive and may not be used in ignitable atmospheres. The system must not be operated with explosive gases or mixtures and it must be ensured that explosive gases or mixtures do not form during the process.

4.2 Requirements for the Furnace Operator



The set-up instructions and safety regulations must be followed, otherwise the furnace will be deemed to have been used improperly, effectively cancelling any claims against Nabertherm GmbH.

This level of safety can be achieved only if all the necessary measures have been taken. It depends on the furnace operator's diligence in planning these measures and controlling how they are carried out.

The operator must ensure that

- all harmful gases are removed from the workplace, for example by an extraction system,
- the extraction system is switched on,
- the workplace is properly ventilated,
- the furnace is operated only in a perfect operating condition and, in particular, that the functions of the safety components are checked regularly.
- the required personal protective equipment is available for and used by the operating, maintenance, and repair personnel.
- these operating instructions, including the supplier documentation, are kept near the furnace. These instructions must be available at all times for anyone working with or on the furnace;
- all the safety and operating instruction signs on the furnace can be read properly. Damaged or unreadable signs must be replaced immediately,
- furnace personnel are informed regularly about all issues involving occupational safety and environmental protection and are familiar with all the operating instructions, especially those involving safety,

- a risk assessment is carried out (in Germany, covered of the Occupational Safety Act) to determine any other hazards that may result from the working conditions particular to the furnace's location,
- all other instructions and safety guidelines that have been determined in a risk assessment for the workplace are compiled in an operation manual (in Germany, covered of the Ordinance Regulating the Use of Operating Equipment).
- Only sufficiently qualified and authorized personnel may operate, maintain and repair the system. This personnel must be trained in how to operate the furnace and must confirm their participation in the training with a personal signature. The training program must be documented in detail. In case an operator is replaced, additional training must also take place. The additional training may only be performed by authorized, trained individuals familiar with the system. The additional training must be painstakingly documented and participation must be evidenced by the names and signatures of the participating employees.
- When ceramics, clay, or glaze are fired, they can emit gases and vapors that are harmful to your health. It is therefore necessary to make sure that the "exhaust gases" emitted from the exhaust air opening are directed outdoors in a suitable manner (ventilate the working area). If adequate ventilation cannot be ensured at the working area, the "exhaust gases" must be removed via a pipe (see "venting exhaust fumes").
- Before placing materials in the furnace, check whether they could harm or destroy the insulation or the heating elements. Materials that could damage the insulation include: alkalis, alkaline earths, metal vapors, metal oxides, chlorine compounds, phosphorous compounds, and halogens. **If applicable, read the labels and instructions on the packaging of materials that you use.**
- If the furnace is used commercially:
Observe the safety regulations applicable in your country. In Germany, the furnace must be checked by a qualified electrician at defined intervals in accordance with a regulation issued by the employers' accident insurance fund.

**Note**

Continuous operation at maximum temperature can lead to increased wear of heating elements, insulation materials and metallic components. We recommend working at approx. **50 °C below maximum temperature.**

**Note**

In Germany, the general accident protection guidelines must be observed. The accident prevention regulations applicable in the country where the furnace is installed must be observed.

4.3 Protective Clothing



Wear heat-resistant gloves to protect your hands.



Wear safety boots to protect your feet.

4.4 Basic Measures During Normal Operation



Risks during normal operation

Before switching the furnace on, check and ensure that only authorized persons are in the working area of the furnace and that no one can be injured as a result of operating the furnace.

Each time, before starting production check and ensure that all the safety equipment functions as intended (for example, that the contact safety switch switches the heating off when the lid is opened).

Before starting production each time, check the furnace for obvious damage and ensure that it is operated only in a perfect condition. Report any defects to Nabertherm Service immediately.

Before starting production each time, remove all materials and objects that are not needed for production from the working area.

At least once every day (see also Servicing and Maintenance) check the following:

- Check the furnace for obvious external damage (visual check), for example insulation, heating elements, power cable, exhaust gas system, if applicable.
- Check that all safety equipment is functioning (for example, that the contact safety switch switches the heating off when the door is opened).

4.5 Basic Measures in Case of Emergency



Note

The power plug is to be pulled out to stop the furnace in case of an emergency.

Therefore, the power plug must be accessible at all times when the furnace is operating so that it can be pulled out quickly in case of an emergency.

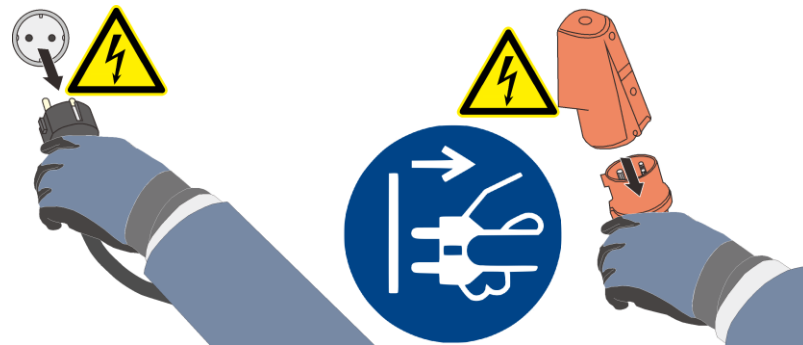


Fig. 12: Pull the power plug (similar to picture)

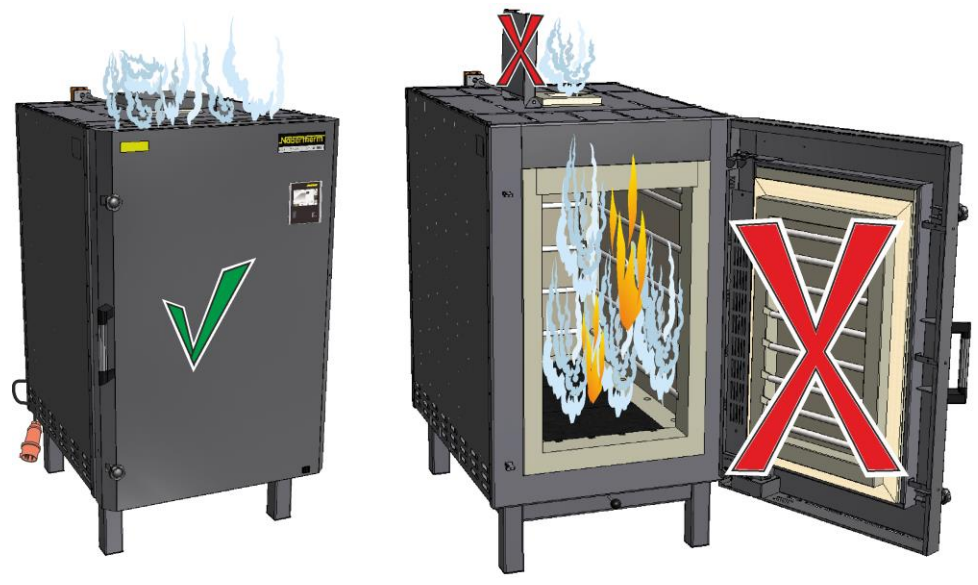


Risks during Normal Operation!

Switch the furnace off immediately in case of unexpected occurrences in the furnace (e.g. a lot of smoke or unusual smells). Wait until the furnace has cooled naturally to room temperature.

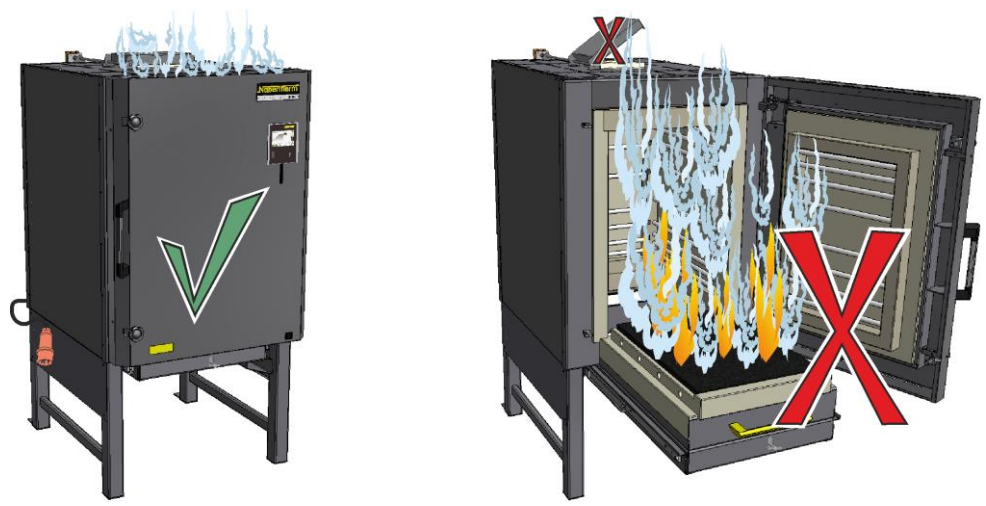
In case of fire, keep the door and exhaust air flap (if present) closed. This prevents smoke spreading and oxygen entering the furnace. Immediately disconnect the power plug.

Keep doors and windows closed. This prevents smoke spreading. Immediately notify the fire service, regardless of the extent of the fire. When you phone the fire service, remain calm and speak clearly.

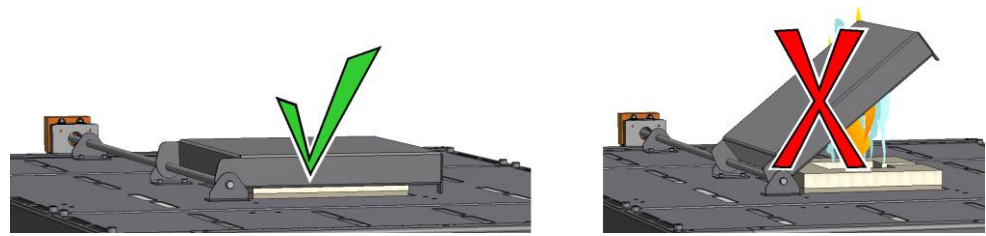


Similar to picture

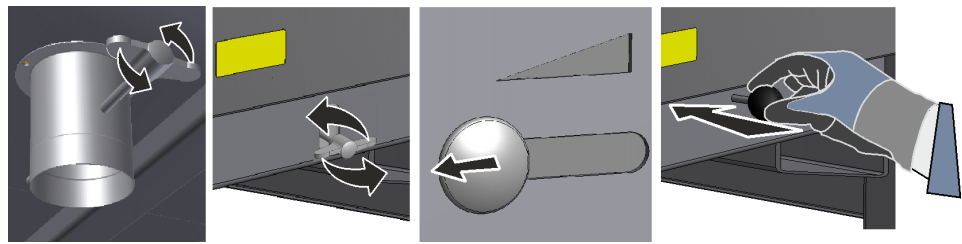
Similar to picture



The exhaust-air flaps must remain closed.






Close the fresh-air flap or adjustable fresh-air inlet
(model-related).
Similar to picture



Fresh-air flap

Adjustable fresh air inlet

 DANGER		
	<ul style="list-style-type: none"> • Danger of electric shock. • Risk of fatal injury. • Work on electrical equipment may be carried out only by qualified electricians or by trained personnel authorized by Nabertherm. • Before starting work, pull out the power plug 	

4.6 Basic Measures for Servicing and Maintenance



Maintenance work must be performed by authorized persons, following the maintenance instructions and the accident prevention regulations. We recommend that the maintenance and repair work be carried out by the service team of Nabertherm GmbH. Non-compliance may cause injuries, death, or considerable damage to property.

Switch the furnace off at the power supply **and pull out the plug.**

The furnace must be completely empty.

When cleaning furnaces, control cabinets, or electrical equipment housings, never spray them with water.

When maintenance or repair work has been completed, before recommencing production ensure the following:

- Check that loosened screw connections/tensioning straps have been re-tightened,
- Reinstall protective equipment, screens, and filters (if applicable),
- Remove all material, tools, and other equipment used for the maintenance or repair work from the working area of the furnace,
- Power cables may be replaced only with similar, approved cables.

4.7 General Risks with the Furnace



Warning – General hazards!

Risk of burning on the furnace housing

The door handle can be extremely hot when the furnace is operating; wear protective gloves

Risk of crushing from moving parts (door hinges)

Dangerous high voltages are present at the control cabinet (if applicable) and at the terminal boxes on the system.

Do not insert objects into openings in the furnace housing, exhaust-air holes or cooling slits of the switchgear or furnace (if present). Ignoring this warning can result in electric shock.

Risk of fire if using an extension cable:

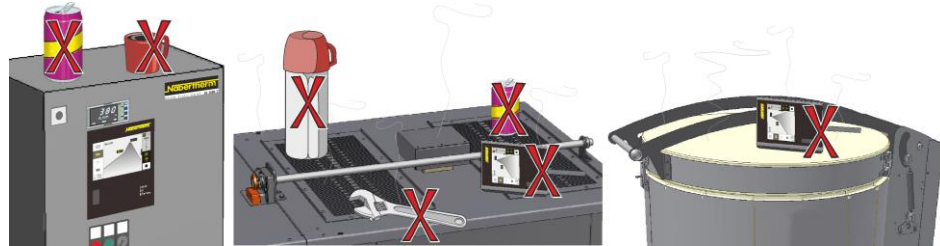
For all furnace models with a plug-in connection:

If an extension cable or a power board are used, their maximum electrical load must not be exceeded. Do not operate the furnace with an extension cable if you are not sure if grounding is guaranteed.






Warning – General Hazards

No objects may be placed or set down on the furnace or switchgear. There is a risk of fire or explosion.



DANGER



- **Danger caused by incorrectly entered cut-off temperature at the over-temperature limiter/over-temperature limiter with motor driven reset**
- **Risk of fatal injury**
- If, as a result of over-temperature from the charge and/or the operating equipment, a charge is likely to be damaged at this pre-set cut-off temperature of the over-temperature limiter/over-temperature limiter with motor driven reset, or if the charge itself becomes a source of danger for the furnace or its surroundings, the cut-off temperature must be reduced on the over-temperature limiter/over-temperature limiter with motor driven reset to the maximum permissible value.

	 DANGER	
	<ul style="list-style-type: none"> • Danger from electrocution • If there is no earth connection, or the earth connection is poorly connected, the result may be a deadly electrical shock. • Do not insert any metallic objects such as thermocouples, sensors or tools into the furnace chamber without having previously ensured that the plant has been correctly earthed. Entrust the job of making a earth connection between the object and the furnace housing to a qualified electrical technician. Any objects inserted into the furnace must be inserted only through those openings intended for this purpose. 	

4.8 Safeguarding against Dangers from Excess Temperatures

Over-temperature limiters and over-temperature limiters with automatic reset to protect against over-temperature in the furnace are available for Nabertherm GmbH furnaces either as a standard feature (depending on the model series) or as additional equipment (customized design).

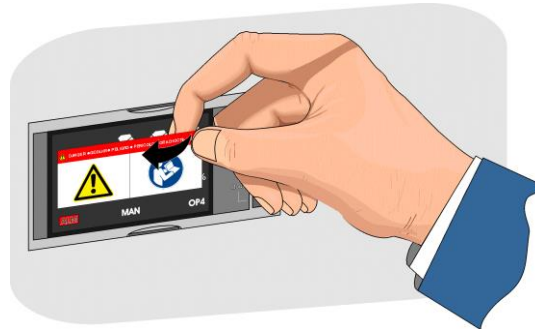
Over-temperature limiters and over-temperature limiters with automatic reset monitor the furnace temperature. The display shows the most recently set cut-off temperature. If the furnace temperature rises above the pre-set cut-off temperature, the heating is shut down to protect the furnace, the charge and/or the operating equipment.

	 DANGER
	<ul style="list-style-type: none"> • Danger caused by incorrectly entered cut-off temperature at the over-temperature limiter/over-temperature limiter with motor driven reset • Risk of fatal injury • If, as a result of over-temperature from the charge and/or the operating equipment, a charge is likely to be damaged at this pre-set cut-off temperature of the over-temperature limiter/over-temperature limiter with motor driven reset, or if the charge itself becomes a source of danger for the furnace or its surroundings, the cut-off temperature must be reduced on the over-temperature limiter/over-temperature limiter with motor driven reset to the maximum permissible value.

Read the operating instructions of the over-temperature limiter/over-temperature limiter with automatic reset before starting the furnace. The safety sticker must be removed from the over-temperature limiter/over-temperature limiter with automatic reset. When a change is made in the heat treatment program, the maximum permissible cut-off temperature (alarm trigger temperature) on the over-temperature limiter/over-temperature limiter with automatic reset must be checked or re-entered.

Depending on the physical characteristics of the furnace, we recommend that you set the maximum target temperature of the heating program in the controller between 5 °C and 30 °C below the trigger temperature of the over-temperature limiter/over-temperature

limiter with automatic reset. This prevents unwanted triggering of the over-temperature limiter/over-temperature limiter with automatic reset.



Description and function, see the Operating Instructions of the over-temperature limiter/over-temperature limiter with automatic reset.

Fig. 13: Removing the sticker (similar to picture)

5 Transportation, Installation and Initial Start-Up

5.1 Delivery

Check that everything is complete

Compare the delivered items with the delivery note and the purchase order documents.

Immediately notify the carrier and Nabertherm GmbH of any missing or damaged parts, as complaints at a later date cannot be acknowledged.

Danger of injury

When the furnace is being lifted, parts of the furnace or the furnace itself could topple over, slip, or fall. Before the furnace is lifted, make sure no one is in the working area. Appropriate protective gloves must be worn.

Safety Instructions

- Industrial trucks (e.g.: crane/pallet truck) must be operated only by authorized personnel. The operator bears sole responsibility for safe operation and the load.
- Use only lifting equipment with sufficient load-bearing capacity.
- When the furnace is being lifted, make sure that the ends of the forks or the load do not catch on neighboring goods. Use a crane to move tall parts, such as control cabinets.
- Lifting gear must be attached only to positions that have been designated for this purpose.
- Attachments, piping, or cable conduits must never be used to affix lifting gear.
- Attach transportation equipment only to positions intended for this purpose.



Note

Wear protective gloves when installing the furnace.



Risks during normal operation

Suspended loads are dangerous. Working beneath a suspended load is prohibited. There is a risk of fatal injury.



Note

Safety and accident prevention guidelines applicable for forklift trucks must be followed.

Transportation with a Pallet Truck

Observe the maximum permitted capacity of the pallet truck.

1. Our furnaces are delivered ex works on wooden frames to facilitate unloading. Transport the furnace in its original packaging and with suitable equipment to prevent any damage. Remove the packaging only when the furnace is in its final location. When transporting the furnace, make sure it is secured against sliding, toppling over, and damage. The furnace should be transported and installed by at least two persons. **Do not store the furnace in damp rooms or outdoors.**
2. Push the pallet truck underneath the transportation frame. Make sure that the pallet truck is **completely** beneath the frame. Pay attention to neighboring goods.

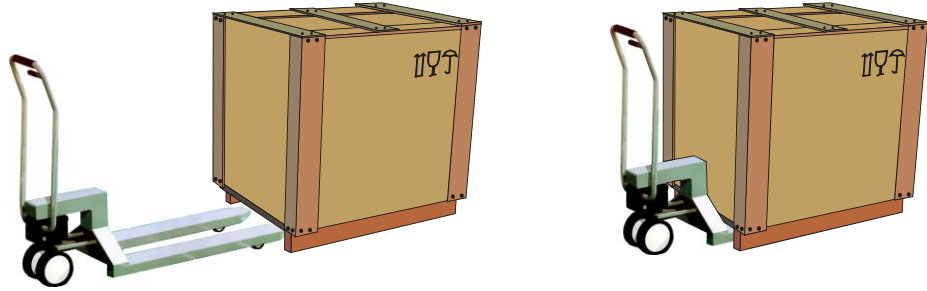






Fig. 14: Pallet truck is pushed **completely** beneath the transportation frame




3. Lift the furnace carefully and pay attention to its center of gravity. When the furnace is being lifted, make sure that the ends of the forks or the load do not catch on neighboring goods.
4. Make sure that the furnace is balanced safely; if not, attach securing equipment. Push the furnace carefully, slowly and with the pallet truck at its lowest position. Do not transport the furnace on inclines.
5. Carefully lower the furnace at its final position. Pay attention to neighboring goods. Try not to set it down too abruptly.

Symbols:

The symbols for handling packaging are defined in ISO R/780 (International Organization for Standardization) and in DIN 55402 (German Institute for Standardization).

Description	Symbol	Explanation
Fragile		This symbol is to be attached to fragile goods. Goods marked like this are to be handled carefully and must not be thrown or tied up.
This side up		The freight must be transported, transshipped, and stored in such a way that the arrows point upward. The freight must not be rolled, folded, or stored on edge. However, the package does not have to be packed on top of other freight.
Keep dry		Products with this symbol must be protected against high air moisture, hence, they must be stored under cover. If particularly heavy or bulky packages cannot be stored in halls or sheds, they must be covered carefully with a tarpaulin or similar.

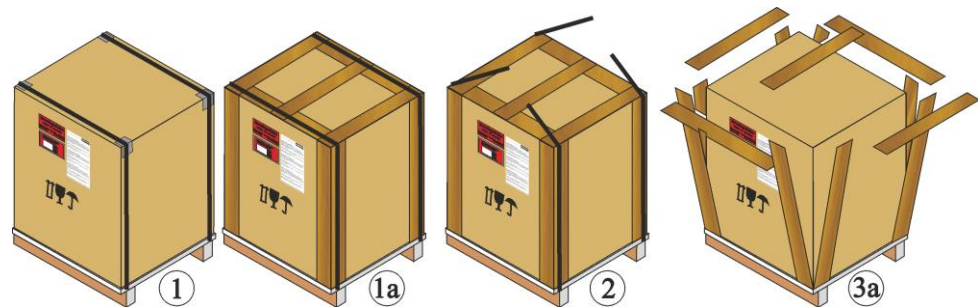
Description	Symbol	Explanation
Sling here		The symbol shows only where the sling should be attached, not the method of slinging. If the symbols are at an equal distance from the middle or center of gravity of the package, the package hangs straight if the slings are the same length. If this is not the case, the sling on one side has to be shortened.

⚠ CAUTION		
 	<ul style="list-style-type: none"> • Device may slip or topple over. • Damage to the device. • Risk of injury from lifting heavy loads. • Transport device only in original packaging. • Several people must carry the device. 	

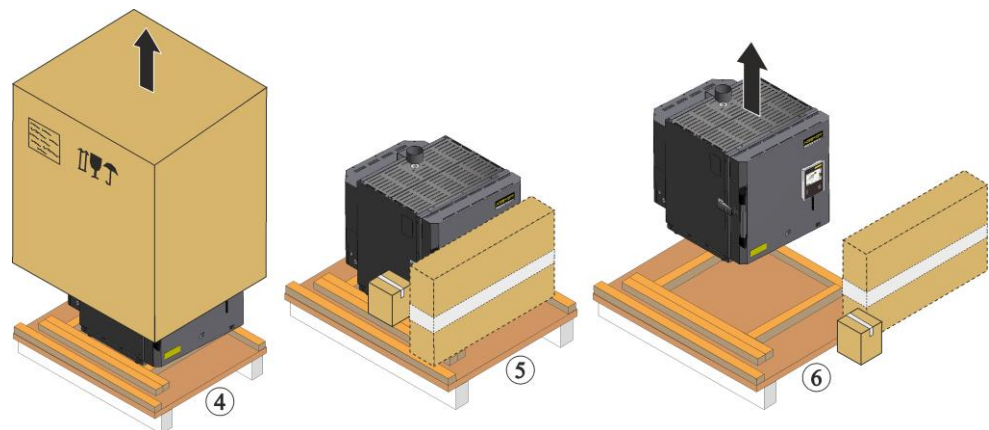
5.2 Unpacking (N 40 E(R) – N 100 E)



Wear protective gloves



1. Check the transportation packaging for possible damage.
2. Remove tensioning straps from the transportation packaging.
3. Slacken screws and remove wooden casing from the covering box (if available 3a).



4. Carefully raise the covering box and remove from the pallet.
5. A flat box containing the accessories for your furnace (ceramic insert plate or optionally a cable) is located on the rear wall of the furnace. Compare the scope of

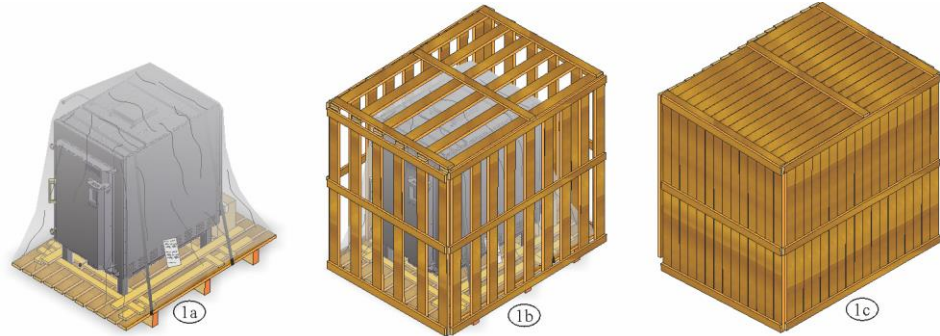
delivery with the delivery note and the order documents, see chapter "Delivery".
Loosen screws or nails from the retaining strips and remove.

6. Remove retaining strips from the pallet.

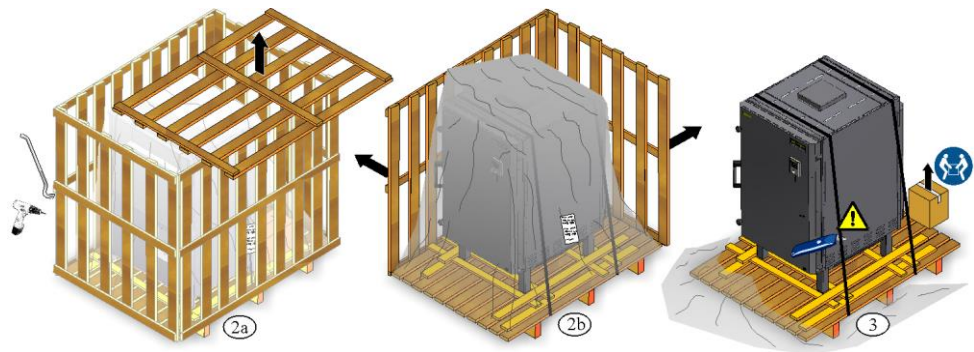
5.3 Unpacking (N 140 E(L) – N 2200(H)(14)(G) – NW 150(H) – NW 300(H))



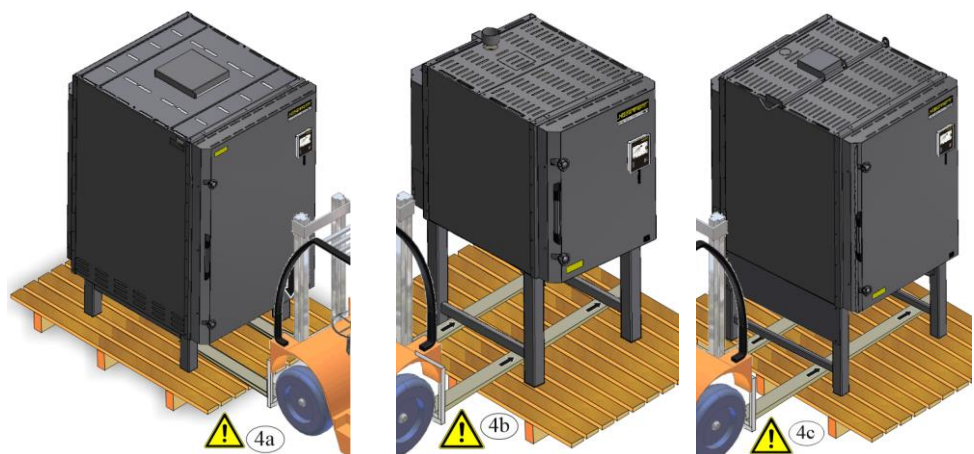
Wear protective gloves



1. Check the transport packaging for any signs of damage. The packaging differs depending on size, weight or installation site and, based on this, is provided in one of the following ways. On a pallet, in a wooden cage or in a wooden box.



2. Remove screws/staples and then carefully remove the wooden siding from around the base. Remove any plastic transportation sheeting.
3. Remove any transportation sheets, straps and packaging materials.



N 140 E(LE) –
N 2000 (H)(14)(G)

N 140/S – N 300/S

NW 150(H) – NW 300(H)

- The furnace frame is made of thick steel sections. Move the forklift forks into position under the furnace (4a) or, if the furnace has a base, under the base, as shown in the picture (4b-4c), carefully avoiding any attachments and lines, which, if necessary, should be removed first. Make sure that the forks of the forklift are **completely** under the frame. Mind the nearby transported goods.

Carefully lift the furnace from below minding the center of gravity. When lifting make sure that the fork tips or the load itself do not get caught on nearby stacked goods. Drive carefully, slowly and **in the lowest** position. Do not drive over any steep surfaces. Set the furnace carefully down at the installation site. Avoid any sudden drops.

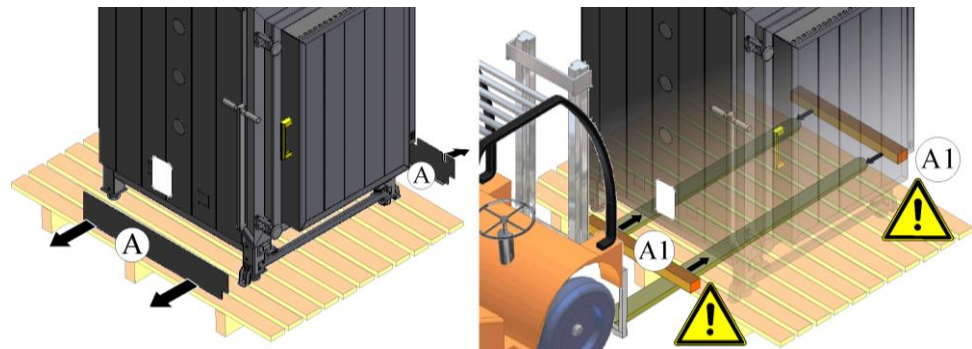


Caution

We recommend that the system be moved to the installation site over longer distances or over bumpy surfaces using a forklift or a pallet lift.

5.4 Unpacking (NW 440(H) – NW 2200(H))

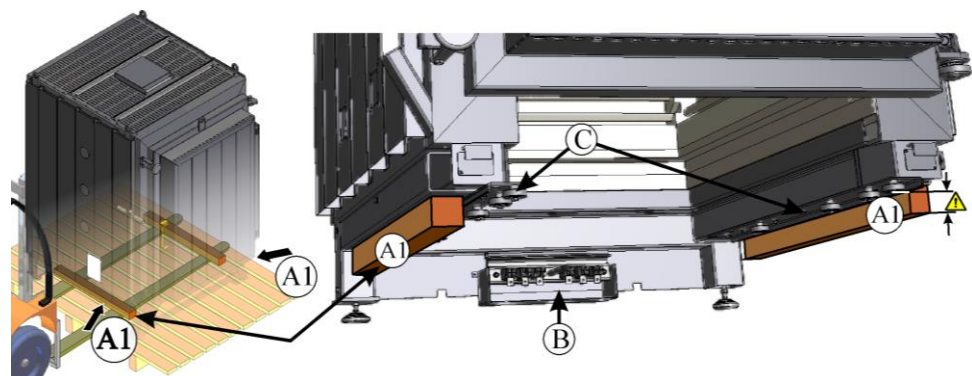
Transportation with suitable forklift truck



When moving the furnace with the help of appropriate forklifts remember:

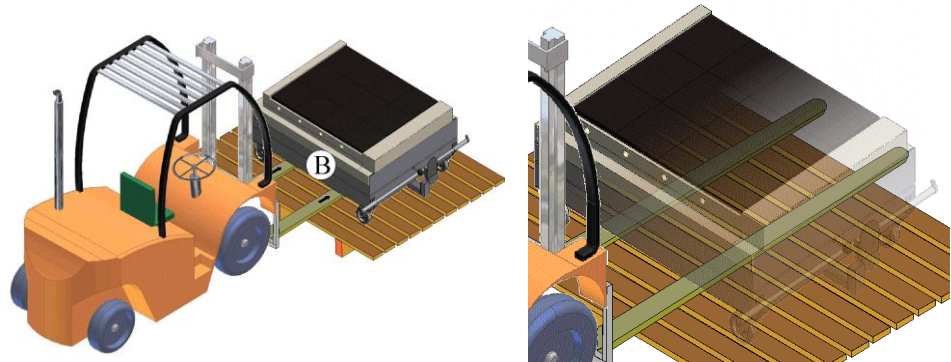
Some furnace models have side panels (A) that must be removed before removal from the frame of the furnace. Ignoring this results in damage to the side panels.

Move the forklift forks completely under the furnace frame and set it onto **wood platform**. Avoid damaging any attachments, pipes or cable raceways.



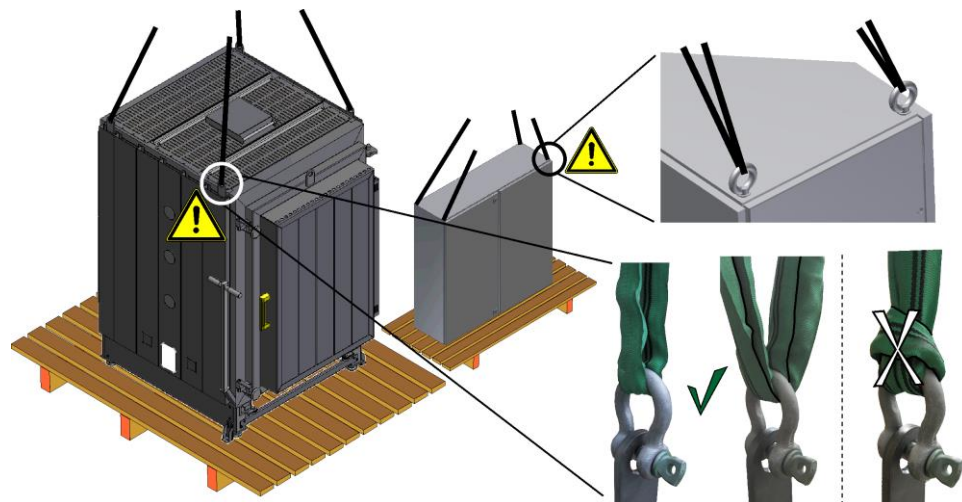
Place suitable squared timbers (A1) (at least 50 x 50 mm) under the furnace frame. You must ensure that they are **not** positioned under the guide rails and rollers (C). Ignoring this results in damage to the guiderails and rollers.

Once the squared timbers have been positioned between the frame and the forklift forks, the furnace can be lifted carefully and slowly, paying close attention to the center of gravity. When lifting make sure that the fork tips or the load itself do not get caught on nearby stacked goods. Drive carefully, slowly and **in the lowest** position. Do not drive over any steep surfaces. Set the furnace carefully down at the installation site. Avoid any sudden drops.



The furnace frame is made of thick steel sections. Move the Forklift truck forks under the bogie. Avoid damaging any attachments, pipes or cable raceways. Make sure that the forks of the forklift are completely under the frame of the bogie. Mind the nearby transported goods. Drive carefully, slowly and in the lowest position. Do not drive over any steep surfaces. Set the bogie carefully down at the installation site. Avoid any sudden drops.

5.5 Furnace or Switchgear with Transportation Rings (if included)



The inner diameter of the lifting rings is roughly 35 mm. Attach an appropriate shackle to all the lifting rings.

Only use a suitable transportation strap on the shackle. The furnace/switchgear must not be lifted by its attachments, pipes or cable conduits. Lifting belts must not be tied together.

Avoid any sudden upward jerks. Working beneath a suspended load is prohibited. The risk of death is imminent. Lift and lower the furnace/switchgear carefully.

Note

In Germany, the general accident protection guidelines must be observed. The accident prevention regulations applicable in the country where the furnace is installed must be observed.

5.6 Transport Securing Device/Packaging

The furnace packaging prevents damage during transportation. Make sure that you remove all packaging material. All packaging material can be recycled. The packaging was designed so that no special description is necessary.



Note

Please keep the packaging for possible shipping or storing of the furnace.



Safety Information

Do not allow children to play with packaging parts. They are at risk of suffocation from folding boxes and plastic film.



Note

No special transportation securing equipment is available for this furnace

During transportation, the furnace collar and door insulation are protected against mechanical effects all round with foil or cardboard strips (depending on the model). We recommend that you remove this protection only when the furnace is installed and set up.

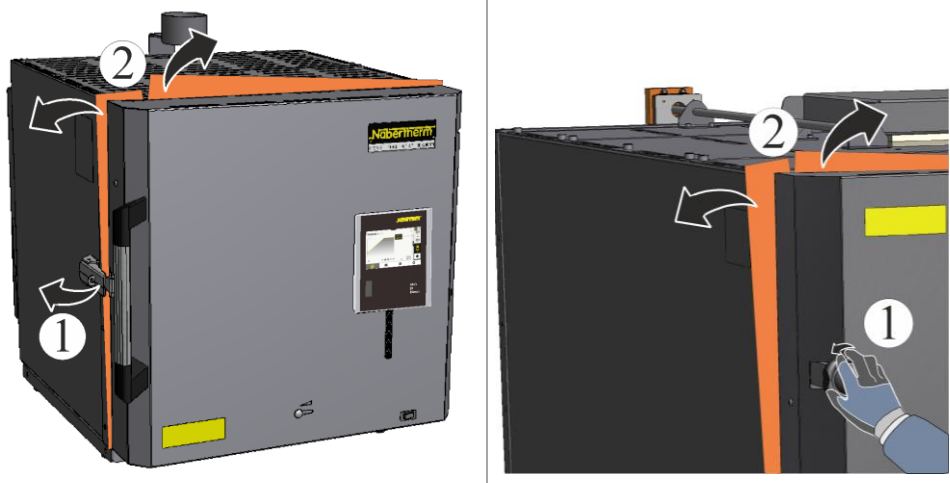


Fig. 15: Example: Removing the transportation protection (similar to picture)

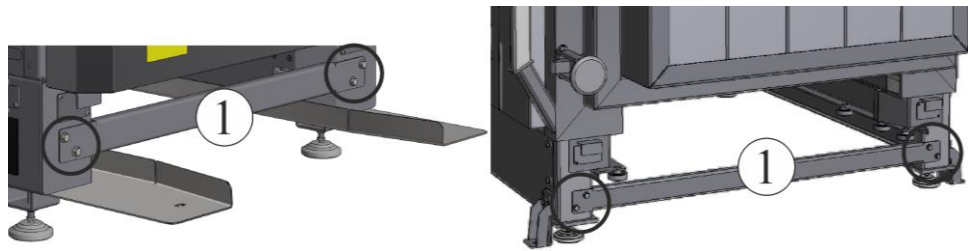
NW 440(H) – NW 2200(H)

Transportation fittings are for safe and secure transportation and to prevent damage to the furnace door and the furnace housing during installation.



Caution

The furnace must be securely anchored to the floor before the transportation fittings are removed, see the section "Installation (Furnace Location)". While the furnace is being anchored to the floor the door/lift door must remain locked. Any other sequence will result in damage.



1 = Transport rod (must remain in place until the furnace has been securely anchored to the floor)

Fig. 16: Transportation fitting (similar to picture)

6 Constructional and Connection Requirements

When setting up the furnace, these safety instructions must be followed:

Floor Characteristics

- The furnace must be positioned in a dry room as stated in the safety instructions.
- The floor must be level to permit the furnace to stand upright.
- The load-bearing capacity of the floor must be rated to take the weight of the furnace plus the operating personnel.
- Place the furnace on a **non flammable** surface (fire safety class A DIN 4102 – Example: concrete, tiles, glass, aluminum or steel) so that any hot material falling from the furnace cannot ignite the surface.

Installation Location

- The operator is responsible for adequate ventilation by installing the appropriate systems to supply fresh air and to vent exhaust air. If a batch emits gases or vapors, adequate ventilation of the installation site must be provided as well as a suitable exhaust air venting system. A suitable vent for combustion exhaust must be supplied by the customer
- Make sure that the heat radiated by the furnace is vented (consult a ventilation expert, if necessary)
- Although the furnace is well-insulated, the exterior surfaces of the furnace radiate heat. If necessary, this heat must be dissipated (**a ventilation technician may need to be consulted**). In addition, a minimum clearance (**S**) of 0.5 m on all sides and 1 m above the furnace must be maintained to flammable materials. In individual cases, more space must be chosen in order to match the local conditions. For **nonflammable materials**, the minimum **side** clearance can be reduced to 0.2 m.
- The furnace must be protected against weather and caustic atmospheres. Nabertherm accepts no liability or warranty claim for any corrosion damage as a result of installation in damp surroundings or for similar reasons.
- The furnace and switchgear are not designed to be operated outdoors.





Fig. 17: Minimum safety distance to flammable materials


Requirements related to the ambient conditions of the switchgear

- The switchgear x must be readily accessible.
- The floor must be level to permit the switchgear to stand upright.
- The furnace's electrical equipment is designed to operate in temperatures from + 5 °C to 40 °C (104 °F). At a temperature of 40 °C (104 °F) the humidity must not exceed 50 %. At lower temperatures the humidity can be higher (max. 80 %), but there must be no condensation.
- At higher temperatures the switch-cabinet coolers must be used. In case of higher humidity and very low temperatures, heaters must be used.
- The switchgear must be protected against heat, dust and moisture.
- The location must be sufficiently ventilated.

Connecting the switchgear

- When the switchgear is connected to the power source and, as necessary, to the furnace, a **clockwise rotating** field must be executed.
- Both connections must be made by specialized electricians. All applicable rules and legal regulations must be followed.
- Before connecting the furnace, the available supply voltage and frequency must be checked against the values stated on the type plate to ensure that they are identical.
- Check the protective conductor
- Select the cross sections of the feed line as specified in the schematic circuit.

	 DANGER
	<ul style="list-style-type: none"> • Risk of fire, danger to health • Risk of fatal injury • Adequate ventilation must be ensured at the installation location to remove exhaust heat and exhaust gases

	<div style="background-color: red; color: white; text-align: center; padding: 5px;">⚠ DANGER</div> <ul style="list-style-type: none"> • Danger associated with the use of an automatic extinguishing system • Danger to life from electrocution through wetness, suffocation caused by extinguishing gas, etc. • If automatic extinguishing systems are in place to fight fires and protect the building, e.g. sprinkler systems, care must be taken during their planning and installation that no additional hazards are created, for example by extinguishing a pilot light, mixing hardening oil and extinguishing water, shutdown of electrical equipment, etc.
-----------------------------------------------------------------------------------	----------------------------------------------------------------------------------------------------------------------------------------------------------------------------------------------------------------------------------------------------------------------------------------------------------------------------------------------------------------------------------------------------------------------------------------------------------------------------------------------------------------------------------------------------------------------------------------------------------------------------------------------------------------------------------------------------------------------------

6.1 Installation (Furnace Location)

6.1.1 N 40 E(R) – N 100 E

When setting up the furnace, these safety instructions must be followed:

- The furnace must be installed in a dry room in accordance with the safety instructions.
- The table/supporting surface must be flat to enable the furnace to be installed straight. Place the furnace on a **non-flammable** surface (fire safety class A DIN 4102 – Example: concrete, tiles, glass, aluminum or steel) so that any hot material falling from the furnace cannot ignite the surface.
- The carrying capacity of the table must be designed to bear the weight of the furnace incl. accessories.
- The floor covering must be made of non-flammable material so that hot material falling out of the furnace will not cause the floor covering to ignite.

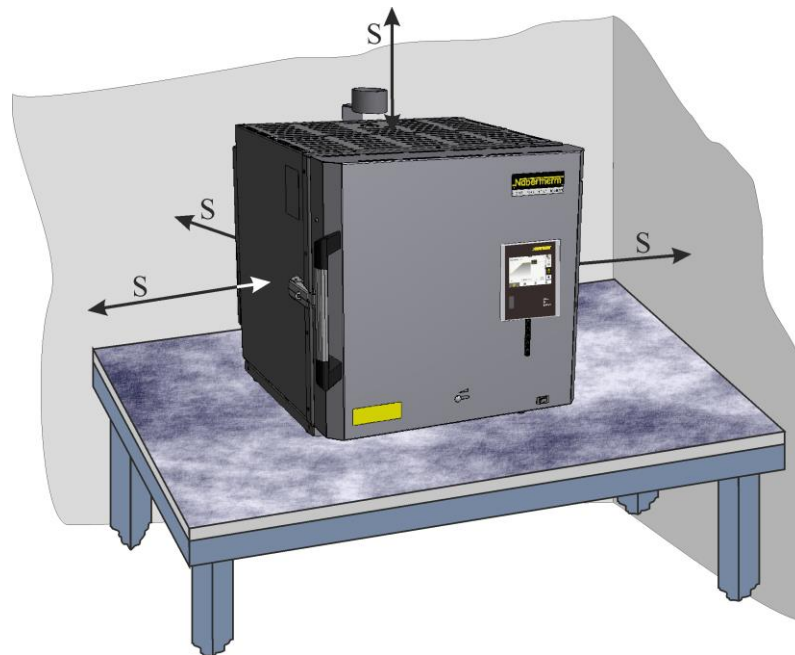
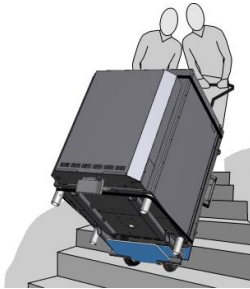


Fig. 18: Minimum safety gap to flammable materials (tabletop model) (similar to picture)

6.1.2 Stairclimber to Transport Chamber Furnaces N 100(H)(14)(G) – N 300(H)(14)(G) (Accessory)



To negotiate all types of stairs, we recommend the use of a **suitable stairclimber** and fastening strap to transport chamber furnaces from N 100(H)(14)(G) to N 300(H)(14)(G).

To prevent the furnaces being damaged, they must only be transported on their side, using the transportation aid that is part of the delivery (accessory).

For specifications, operating components, operation and safety information, please refer to the operating instructions for the stairclimber included with the delivery (not included in the scope of delivery of the transportation aid).

Observe the safety information for the stairclimber.

Nabertherm accepts no liability if the stairclimber is not handled or operated properly.

To transport the furnaces safely with a stairclimber, some models have a transportation aid (accessories), which must be removed when the furnace has been installed. If not already installed on the furnace, the transportation aid must be installed correctly as shown in the figure below.

Dismantling the Collar Protection Strip

Before the transportation frame is installed on the furnace, the collar protection strip must be dismantled from the furnace collar (see figure below). Undo the screws on the collar protection strip and remove it upward (keep the collar protection strip and the screws to reuse them).

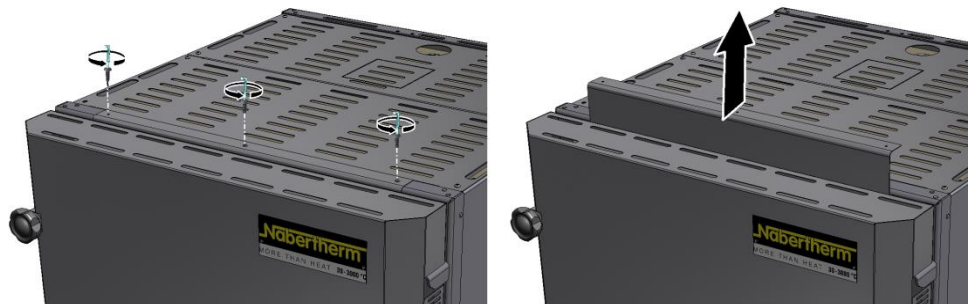


Fig. 19: Dismantling the collar protection strip (similar to picture)

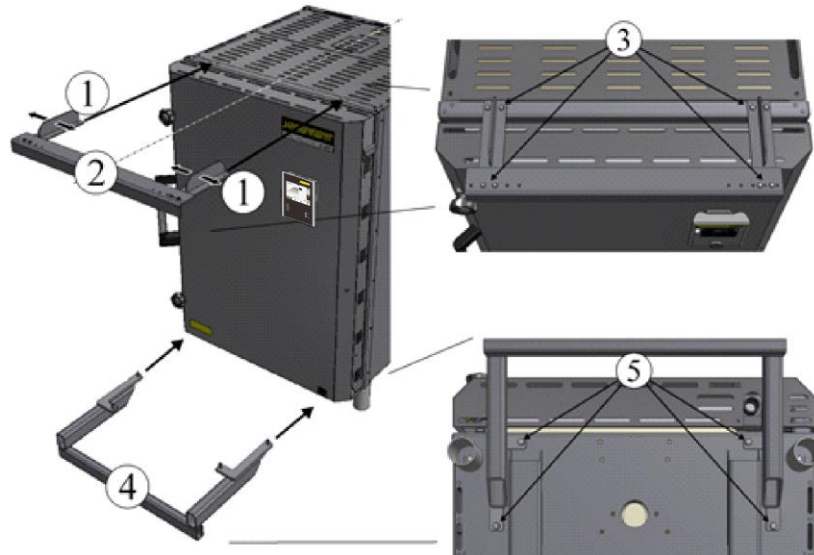
Installing the Transportation Aid

First, place the two brackets (1) at the position of the previously dismantled collar protection strip and connect them using the screws that were included in the delivery (3). The furnace collar has suitable threaded holes for the brackets. When the two brackets have been assembled, screw the support bracket (2) to them using the screws that were included in the delivery.

When the top transportation aid has been assembled, the bottom transportation aid (4) can be fixed to the base of the furnace using the screws that are part of the delivery (5). The bottom of the furnace has suitable threaded holes.

Check all screw connections on the transportation aid.

Transportation aid	Number of screws delivered	Screws
Top transportation aid (1, 2)	8	M5 x 20
Bottom transportation aid (4)	4	M8 x 30



3 = M5 x 20 / 5 = M8 x 30

Fig. 20: Assembling the transportation aid (similar to picture)

Using and Positioning the Transport Straps

The furnace must be secured with **suitable, adequately dimensioned fastening straps** (1a). When securing and transporting the furnace, make sure that **add-on parts, cable ducts, air inlet flap, and controller are not damaged**.

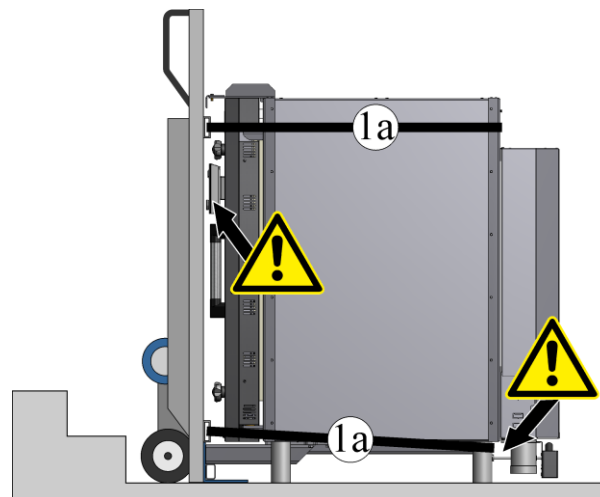
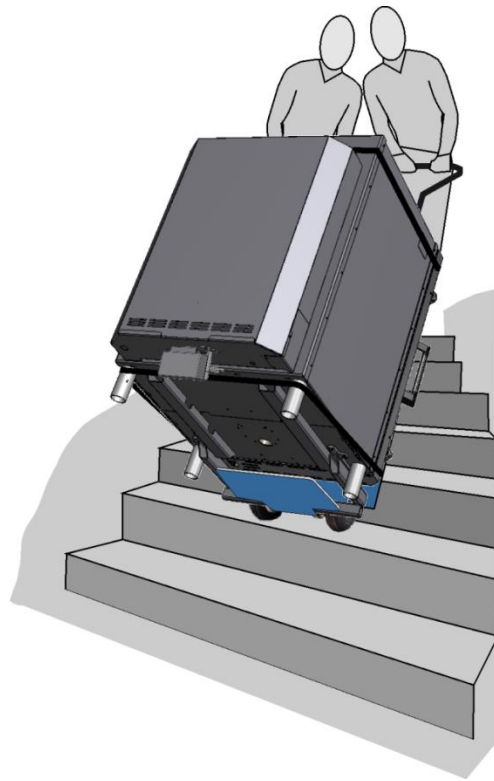


Fig. 21: Using the transport straps (recommendation) (similar to picture)

For technical data, operating components, operation and safety information, please refer to the operating instructions for the stairclimber that are included with the delivery.



Safety Instructions:

Wear suitable work clothing and slip-resistant footwear.

Stairclimbers may be used only by trained persons.

Get an idea of the exact stair situation before you start.

There must be no one in the danger area below the load.

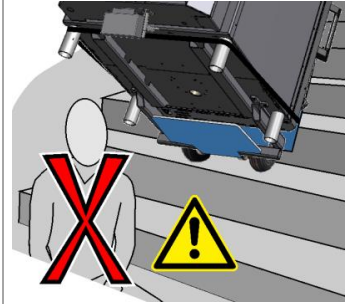


Fig. 22: Safe transportation of a furnace with a stairclimber (similar to picture)

Assembling the Collar Protection Strip

When the furnace has been installed and the transportation aid removed, reinstall the collar protection strip that was previously removed using the appropriate screws.

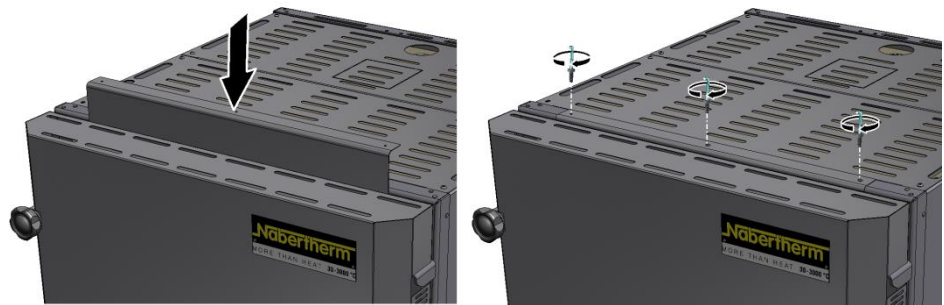
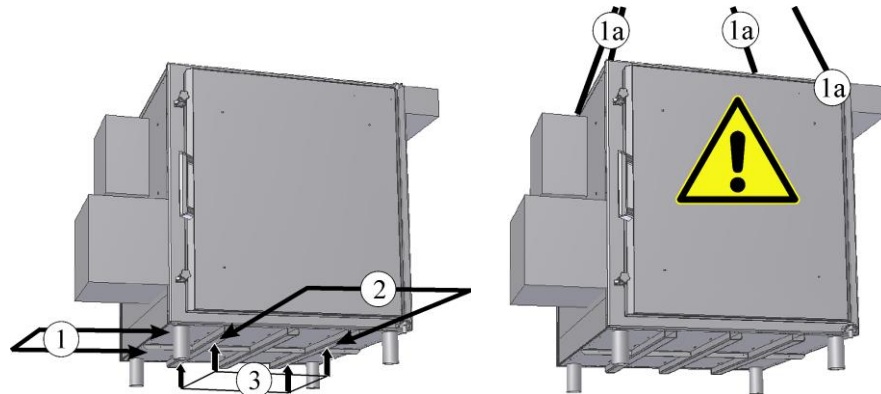


Fig. 23: Assembling the collar protection strip (similar to picture)

Notice

The customer keeps the transportation aid in case it is needed for future transportation/shipment

6.1.3 N 100(H)(14)(G) – N 300(H)(14)(G) Installation of the base frame if it is not already installed



Notice: Do not lift with a crane, this will damage the furnace. Use only suitable forklift trucks

Use a crane to lift the furnace only with models from 1000 liters. Only these furnace models are suitable for transporting with a crane

Fig. 24: Lifting the furnace with a forklift or a crane (models from 1000 liters) (similar to picture)

Lifting the Furnace with a Suitable Industrial Truck

The forks of the industrial truck should be completely inserted under the furnace floor either from the side (1) or from the front (2). Only the floor profiles (3) of the furnace floor may rest on the forks of the industrial truck. Make sure the forks are clear of attachments, pipework or cable conduits. Lift the furnace gently; avoid any sudden movements.

Lifting the furnace with a suitable crane (from 1000-liter model)

There are 4 lifting rings (1a) on the furnace for attaching shackles. The inner diameter of the lifting rings is roughly 35 mm. Attach an appropriate shackle to each of the 4 lifting rings. The lifting belts attached to the shackles must be adequate for the task (see the illustration "Lifting the furnace" in the section entitled "Unpacking"). The furnace must not be lifted by its attachments, pipes or cable conduits. Lifting belts must not be tied together. Lift the furnace gently; avoid any sudden movements.

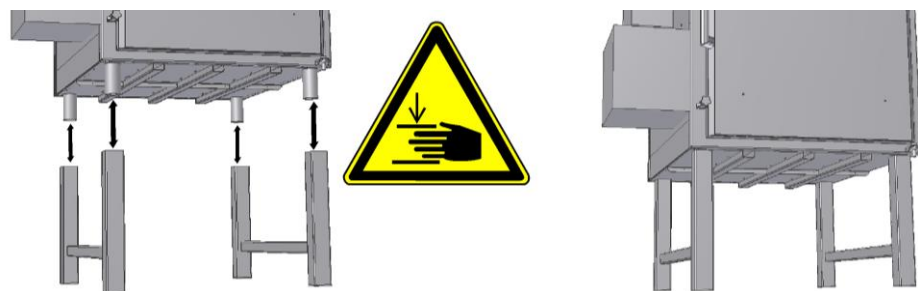
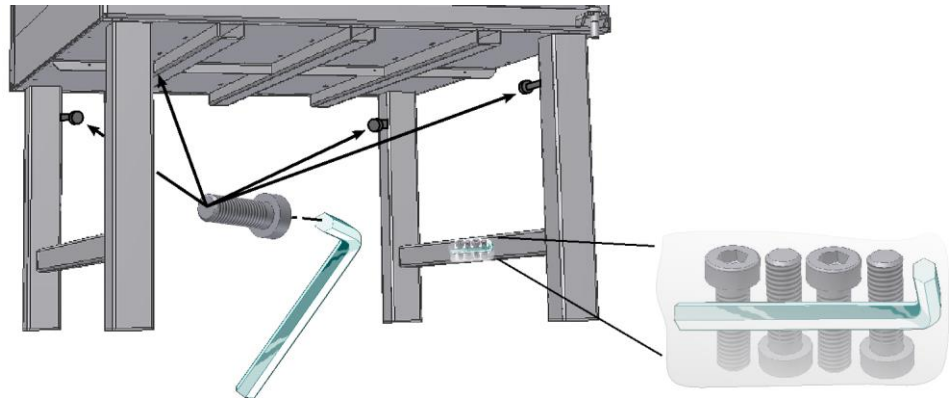


Fig. 25: Lowering onto the base frame (similar to picture)

Lower the furnace carefully onto the base frame and make sure that it rests securely in place.



Scope of delivery: 4x screws M10x30 mm / 1x Allen key 8 mm

Secure the base frame by attaching the screws included in the scope of delivery.

Fig. 26: Secure attachment of the base frame (similar to picture)



Caution

Nabertherm assumes no liability for damages caused by improper installation.

6.1.4 NW 150(H) – NW 300(H)

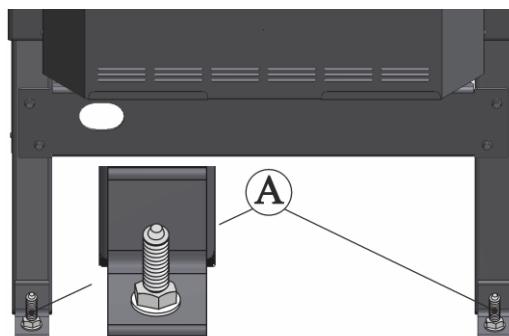
Secure the furnace with drawer to the floor to prevent it toppling over. We recommend that the furnace be installed and assembled by a qualified professional. To allow the heating elements to be replaced and for maintenance, we recommend that a gap of about 0.5 m be left between the back of the furnace and the wall



Note

Make sure you know where the power and water lines are located before you drill any holes. Nabertherm does not assume any liability for possible damage or injuries.

- Securely anchor the furnace to the floor using the brackets (A)
- When charging the furnace with drawer (NW 150(H) – NW 300(H)) pay attention to the **maximum** charge weight. If this is ignored, Nabertherm accepts no liability for damage or injuries.



For the scope of delivery, refer to the installation package (the number of materials delivered may differ depending on the model):
 -Chemical anchor capsule
 -Anchor rod
 (the position of the bracket may differ depending on the model)

Fig. 27: Bolt the furnace to the base (similar to the figure)

6.1.5 NW 440(H) – NW 660(H) (from model year 2022)

When setting up the furnace, these safety instructions must be followed:

- Set the furnace down at the installation location and align accordingly.
- The floor must be level so that the furnace can stand upright. Align the furnace with a spirit level. The furnace can be leveled using the feet to balance out any unevenness (see "Aligning the Furnace").
- When the furnace (1) has been positioned and aligned, the bogie guides beneath the furnace can be lowered. The bogie guides are used to secure the furnace to the floor and to guide the bogie.



Fig. 28: Set the furnace down and position it (similar to picture)

- Undo the screws (2) beneath the floor of the furnace that hold the metal bogie guides. Carefully lower the bogie guides on to the floor.

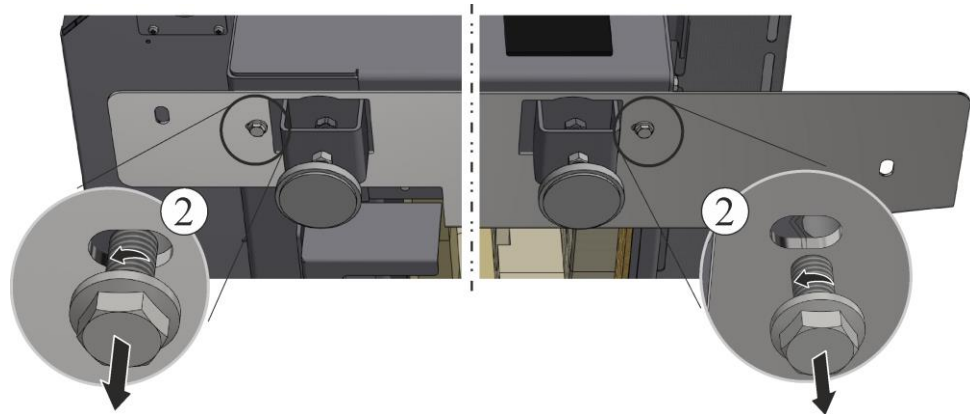


Fig. 29: Lowering the metal plates on the floor of the furnace (similar to picture)

- The transportation rod (3) remains on the furnace until the metal sheets are firmly anchored or secured to the floor. The lowered metal plates are centered on the floor with the furnace feet (4).

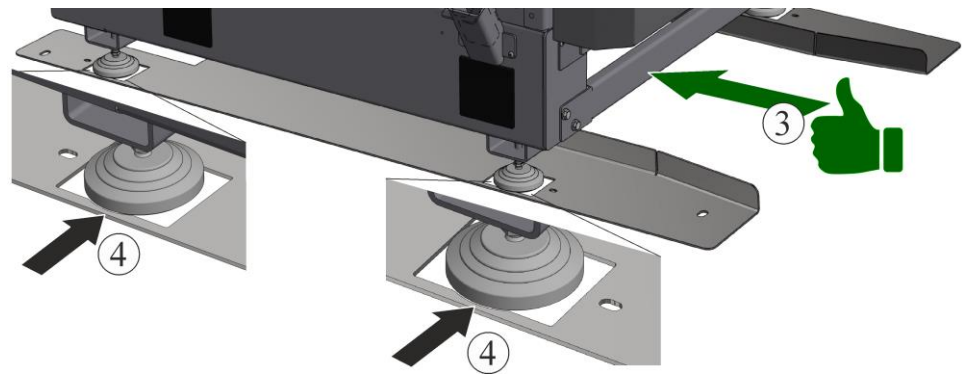


Fig. 30: Check that the metal plates are in the correct position (similar to picture)

The bogie must be positioned in the middle of the furnace. An even gap must be maintained between the insulation of the bogie (Y1) and that of the furnace (Y2).

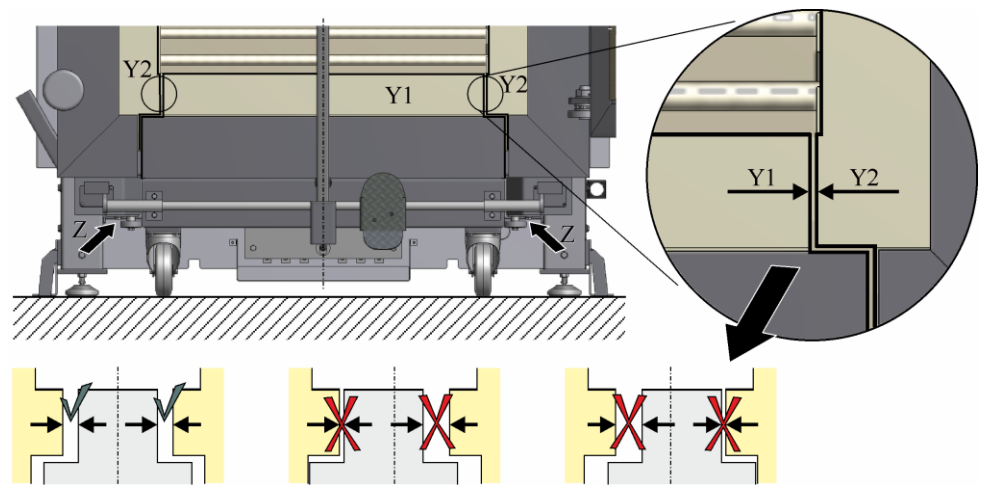


Fig. 31: Aligning the bogie (horizontal alignment of the bogie) (similar to picture)

- The bogie guide rails are secured to the floor with suitable anchor rods (5). Use anchor rods (drill diameter 14 mm) to secure the metal plates to the floor.

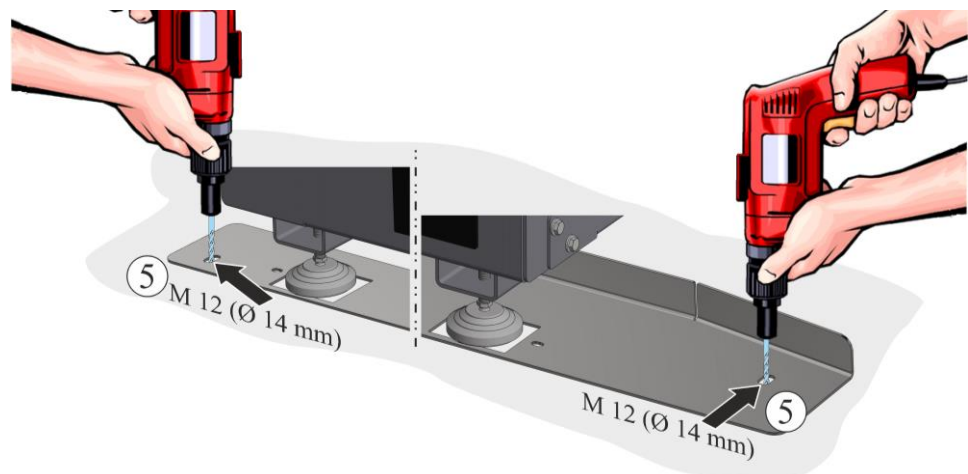


Fig. 32: Drilling into the floor (similar to picture)



Note

Make sure you know where the power and water lines are located before you drill any holes. Nabertherm does not assume any liability for possible damage or injuries.

- To assemble the chemical anchor capsule and anchor rod, refer to "Chemical Anchor Capsule/Anchor Rod Installation Instructions "

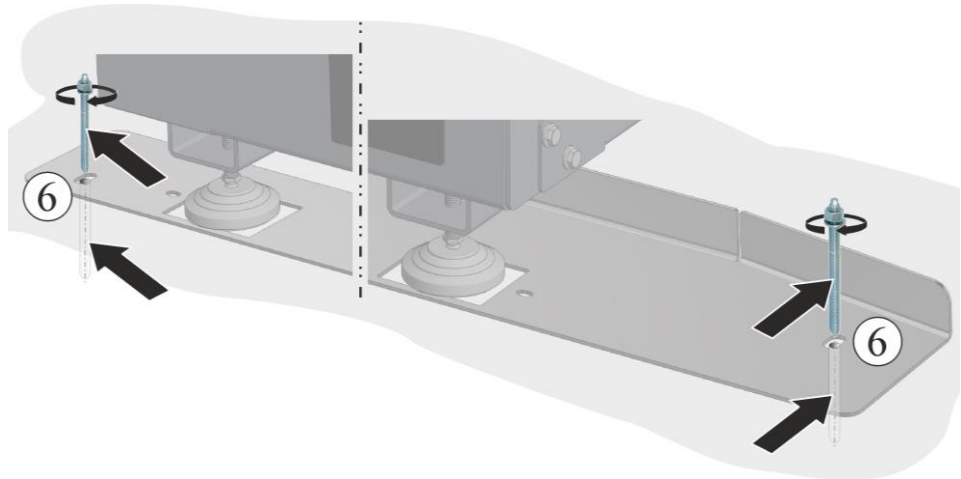


Fig. 33: Anchoring the metal plates to the the floor (similar to picture)

- Once the metal plates have been installed on the floor, use a suitable tool to undo the bolts holding the transportation rod.

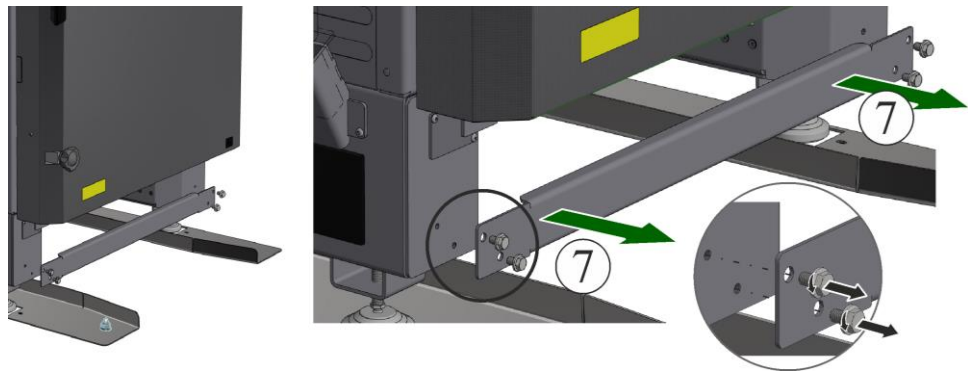


Fig. 34: Removing the transportation rod (similar to picture)

If necessary, check whether the top of the bogie (X1) and the top of the furnace (X2) are at the same level (this applies to the complete length of the furnace/bogie). The height of the furnace can be adjusted at its feet.

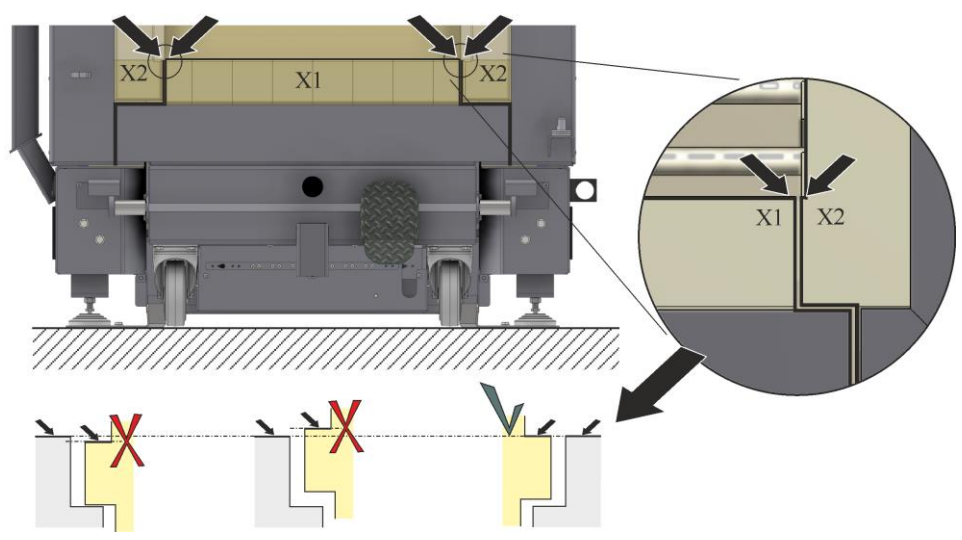


Fig. 35: Aligning the furnace (vertical alignment of the furnace) (similar to picture)



Fig. 36: Check the height along the entire length (similar to the figure)

The bogie must be positioned in the middle of the furnace. An even gap must be maintained between the insulation of the bogie (Y1) and that of the furnace (Y2).

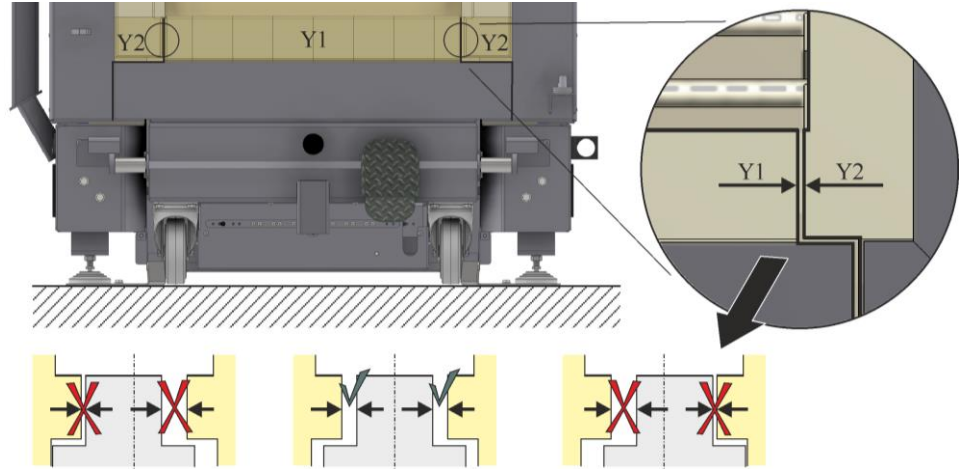


Fig. 37: Aligning the bogie (horizontal alignment of the bogie) (similar to picture)

6.1.6 NW 440(H) – NW 660(H) (to model year 2022) and NW 1000(H) – NW 2000(H)

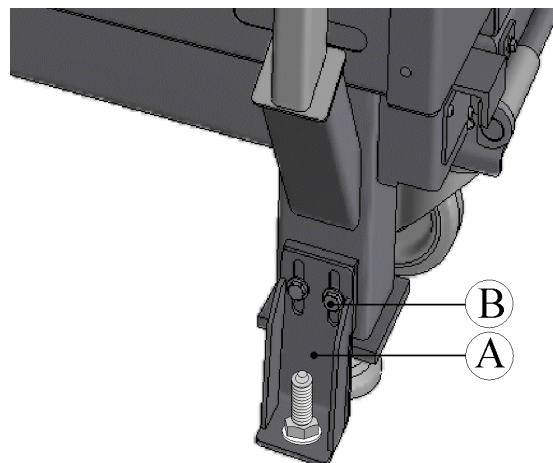
When setting up the furnace, these safety instructions must be followed:

- Set the furnace down at the installation location and align accordingly.
- The floor must be level so that the furnace can stand upright. Align the furnace with a spirit level. The furnace can be leveled using the feet to balance out any unevenness (see "Aligning the Furnace").



Fig. 38: Set the furnace down and position it (similar to picture)

- The transportation rod (3) remains on the furnace until the bracket is firmly anchored or secured to the floor.
- Securely anchor the furnace to the floor using the brackets (A) (installation package included in delivery). Make sure that the bolts (B) in the brackets (B) can be easily loosened so that the brackets can be moved vertically.
- To assemble the chemical anchor capsule and anchor rod, refer to "Chemical Anchor Capsule/Anchor Rod Installation Instructions "



For the scope of delivery, refer to the installation package (the number of materials delivered may differ depending on the model):

- Chemical anchor capsule
- Anchor rod

(the position of the bracket may differ depending on the model)

Fig. 39: Installing the furnace on the floor (similar to the figure)



Note

Make sure you know where the power and water lines are located before you drill any holes. Nabertherm does not assume any liability for possible damage or injuries.

Once the furnace has been successfully installed and secured to the floor, remove the transportation rod with a suitable tool.

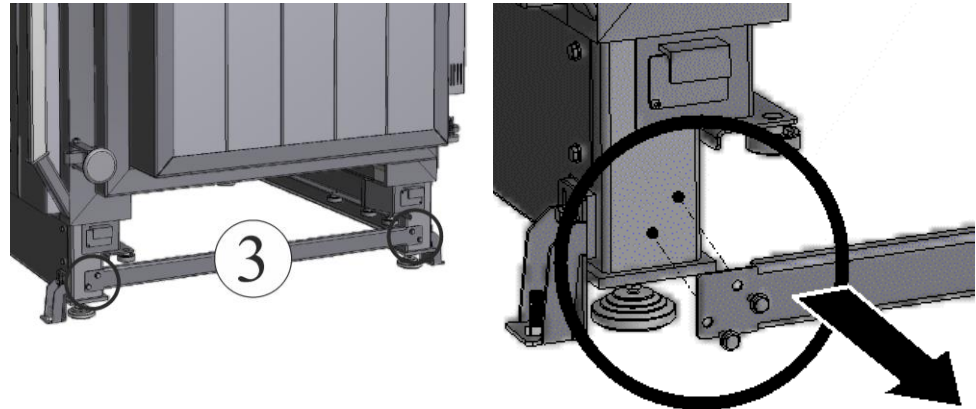


Fig. 40: Removing the transportation rod (similar to picture)

To align the furnace, open the door completely in order to push the bogie in front of the furnace carefully and slowly.

Pull out the draw bar (1) (on the side of the furnace housing) and insert it into the holder (2) of the bogie.

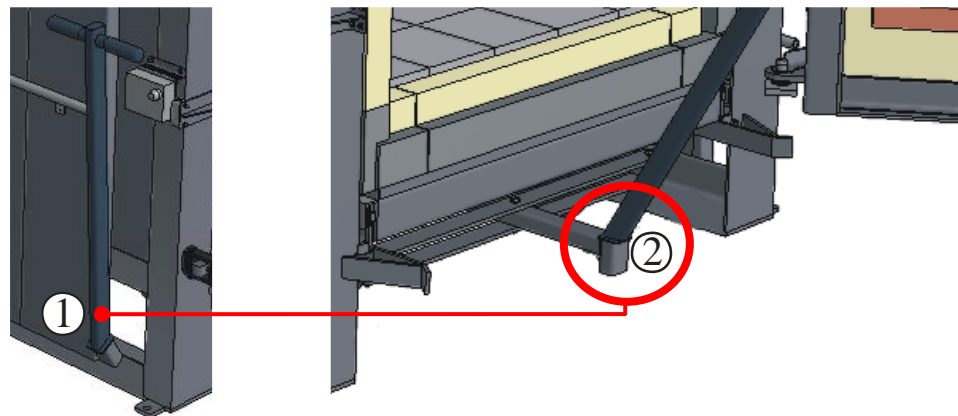


Fig. 41: Insert draw bar

If necessary, check whether the top of the bogie (X1) and the top of the furnace (X2) are at the same level (this applies to the complete length of the furnace/bogie). The height of the furnace can be adjusted at its feet.

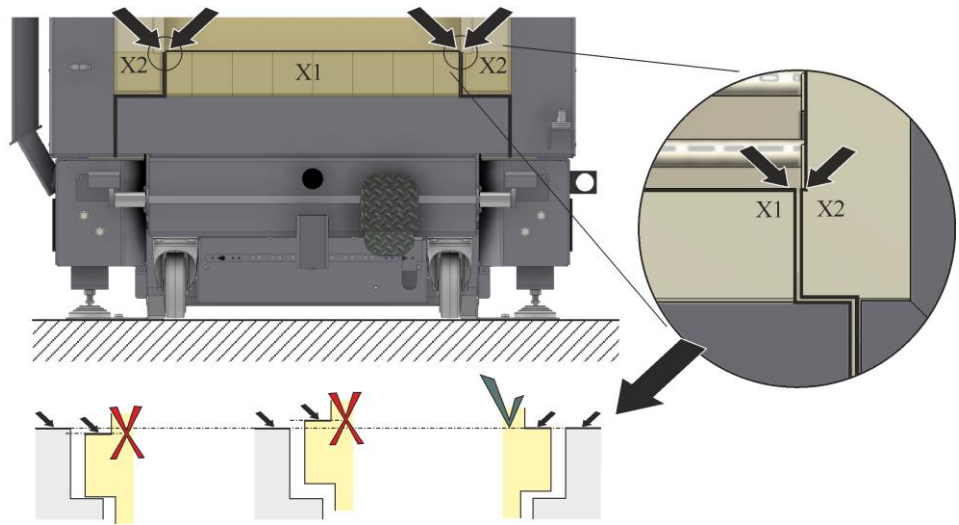


Fig. 42: Aligning the furnace (vertical alignment of the furnace) (similar to picture)



Fig. 43: Check the height along the entire length (similar to the figure)

The bogie must be positioned in the middle of the furnace. An even gap must be maintained between the insulation of the bogie (Y1) and that of the furnace (Y2).

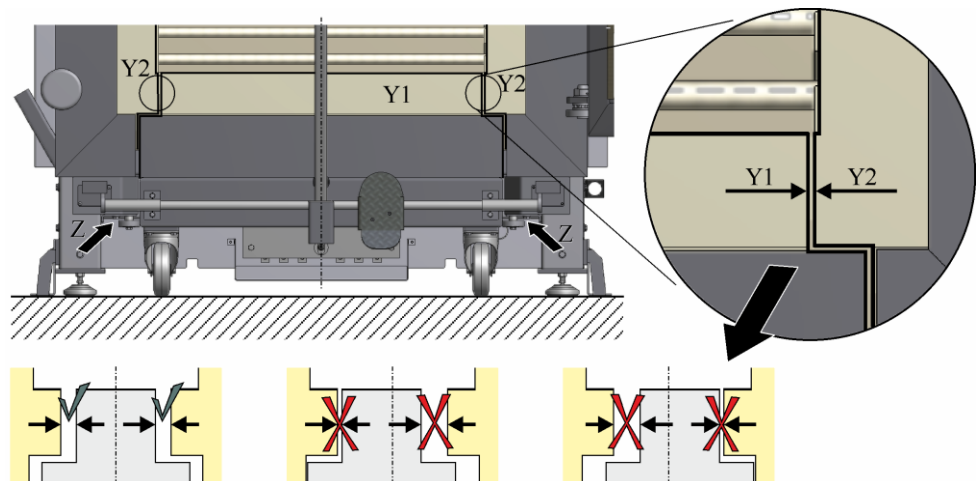
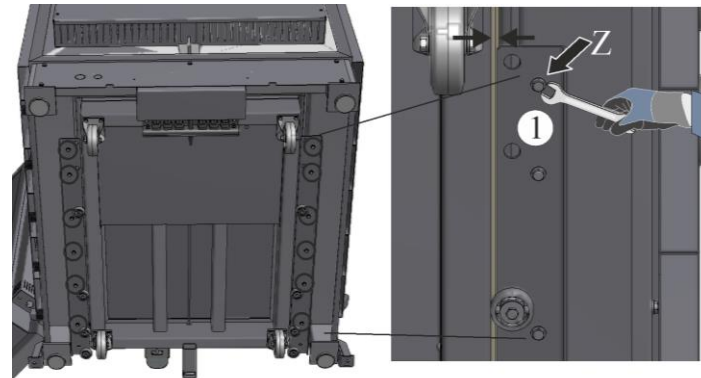


Fig. 44: Aligning the bogie (horizontal alignment of the bogie) (similar to picture)

On the bottom of the bogie there are two panels with guide rollers held in place with bolts. Before centering the bogie (if necessary) slightly loosen the bolts (Z) on the panels with a suitable tool. Center the bogie along its entire length. The guide rollers on the panels must touch the bottom of the bogie. When the bogie has been aligned, replace all the bolts.



The number and position of the rollers and bolts may differ depending on the furnace model.

1 Panel with guide rollers

Fig. 45: Furnace with bogie seen from below (similar to the figure)

Assembling the previously dismantled side panels (model-related)

To transport the furnace to its installation location, the side panels (A) are removed from the frame of the furnace and must be replaced when the furnace has been installed, assembled, and set up.



Fig. 46: Assembling the side panels (similar to figure)

Installation of a Wall Cabinet System (in scope of delivery depending on design/furnace model)

The wall must provide a safe and secure mounting surface. The top edge of the cabinet should not be higher than 2.00 m so that all the operating elements are easy to reach. (Fixing material not included with delivery.)

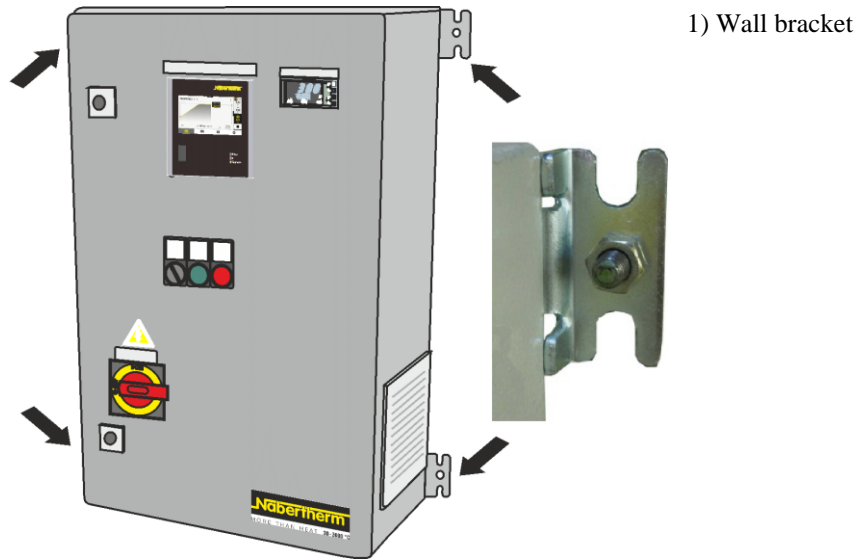


Fig. 47: Wall cabinet system (similar to picture)

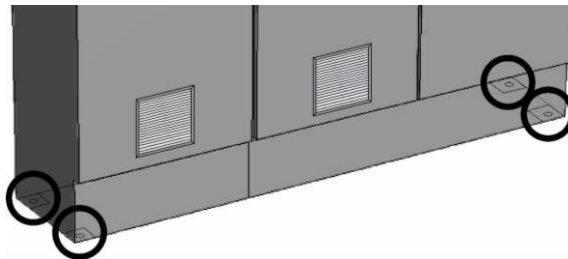


Note

Make sure you know where the power and water lines are located before you drill any holes. Nabertherm does not assume any liability for possible damage or injuries.

Installation of a Free-Standing System (in scope of delivery depending on design/furnace model)

- Secure the switchgear using the screws included in the delivery (The quantity of materials included in the scope of delivery can vary from one model to another).
- The number and position of the screws may differ from one furnace model to the next



Scope of delivery:
-Height adjustment disks
-Threaded anchors

Fig. 48: Installing the switchgear (similar to picture)

Note

To ensure that the floor switchgear cabinets are safely and securely installed we recommend that they be bolted to the floor. The switchgear cabinets supplied by Nabertherm are provided with bores in the base for this purpose.

6.1.7 Installation Package for Installing the Furnace Framework

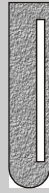

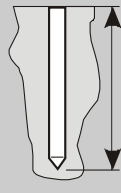


The safe and secure installation of the furnace requires that these safety instructions be followed:

- The floor must be level to permit the furnace to stand upright. Level the furnace with a water level. Use the height adjustment disks from the installation package to compensate for any unevenness in the floor.

- The bearing capacity of the floor must be dimensioned to hold the weight of the furnace and the operators
- Installation of the compound anchor cartridges and anchor rod see "Chemical Anchor Capsule/Anchor Rod Installation Instructions"

6.1.8 Chemical Anchor Capsule/Anchor Rod Installation Instructions

The chemical anchor capsule contains a number of components (synthetic resin, quartz sand) and a special hardener encapsulated in a glass tube. When the anchor rod is vibrated into the cleaned drill hole using a hammer drill or impact drill, the glass is broken up by the chiseled end of the anchor rod and the hardener is mixed with the other components. A fast-setting synthetic resin mortar forms in a reaction, producing a stronger bond between the anchor rod and the drill hole than embedding in concrete would achieve. The absolutely stress-free anchor makes this system far superior to expansion dowels and results in a high load capacity (up to 60 kN) even with small edge distances and axial spacings.

 Chemical Anchor Capsule	 Ø in mm	 mm	 Nm	 Anchor Rod
M10	12	90	20	M10
M12	14	110	40	M12
M14	16	120	50	M14
M16	18	125	60	M16
M20	25	170	150	M20

Suitable Building Materials:

Allowed for uncracked concrete grades B15 to B55. Also suitable for dense natural stone.

Allowable Loads:

Allowed for loads of 3 kN to 60 kN in the compression zone.

The anchor can be fully loaded after the specified cure time.

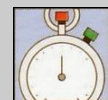


> 20°

10°–20°

0°–9°

-5°–-1°



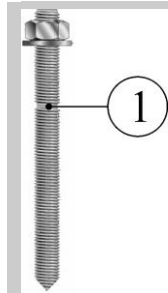

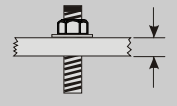

10 min

20 min

45 min

4 h

Anchor Rod


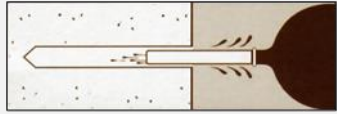

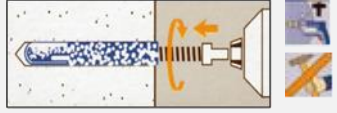


 1) Embedment depth mark	 Anchor Rod	 mm	 mm
	M10	20	130
	M12	25	160
	M14	35	170
	M16	38	190
	M20	70	260

Installation Type:


- Threaded rod

Installation Instructions:

- Insert the anchor rod with a rotary-impact electric tool (impact drill, hammer drill).
- Can also be used in wet concrete and under water.

	Drill hole with depth and diameter according to specifications given in the above table.
	Thoroughly clean (blow out) drill hole.
	Insert chemical anchor capsule completely into drill hole.
	To facilitate installation, the anchor rod has a hexagonal head. Vibrate anchor rod down to embedment depth mark. Then immediately shut off drill and remove from anchor rod.
	The synthetic resin bonds the entire inserted surface of the anchor rod to the wall of the drill hole and largely seals the hole. Do not remove excess resin.
	The anchor can be fully loaded after the specified cure time (see above table).

Hazard Information:

 Xi – Irritant	R 43: May cause skin sensitization on contact.
	S36/37: Wear suitable gloves and protective clothing when
	S60: This product and its container must be disposed of as hazardous waste.
General Information	Change clothes if contaminated with product.
Following inhalation	Ensure adequate ventilation. Consult a doctor in case of symptoms.
Following contact with skin	In case of contact with skin, immediately wash off with plenty of soap and water. Consult a doctor if skin irritation persists.
Following contact with eyes	In case of contact with eyes, rinse thoroughly with plenty of water and consult a doctor.
Following ingestion	Not applicable
Instructions for physicians	Treat symptoms.
Safety data sheet	1907/2006/EC

6.1.9 Removing the Transportation Fittings

During transportation, the furnace collar and door insulation are protected against mechanical effects all round with foil or cardboard strips (depending on the model). We recommend that you remove this protection only when the furnace is installed and set up.

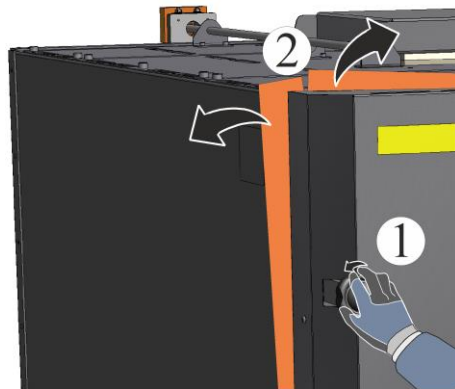


Fig. 49: Example: Removing the transportation protection (similar to picture)

6.1.10 Removing the Foam Mats (NW 440(H) – NW 2200(H))

Between the SIC tiles (1) and bogie to protect the insulation there are foam mats (2) which must be removed. You must ensure that, before using the furnace, all the foam mats under the SIC tiles have been removed.

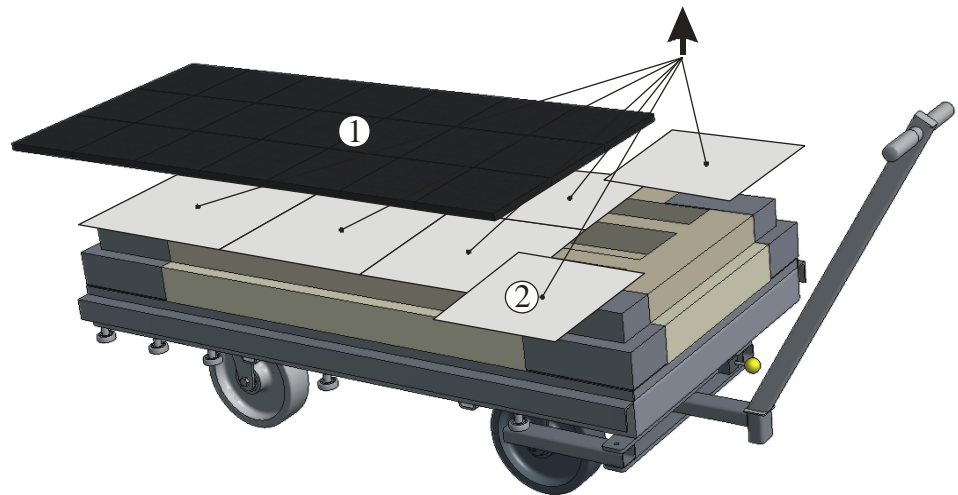


Fig. 50: Removing the foam mats (similar to picture)



Caution

Keep the transportation edging in case it is needed for future transportation or storage. Use the transportation block to prevent damage during transportation.

6.2 Assembly, Installation, and Connection

6.2.1 Assembling the Bypass Connection (Depending on Model)

Mount the bypass connection (model-related) that is part of the delivery on the furnace.

- At the bypass connection position there are screws (1) to assemble the connection; these must be loosened beforehand.
- Place the bypass connection (2) with the screws loosened on to the correct position on the furnace and fasten it with suitable tools.

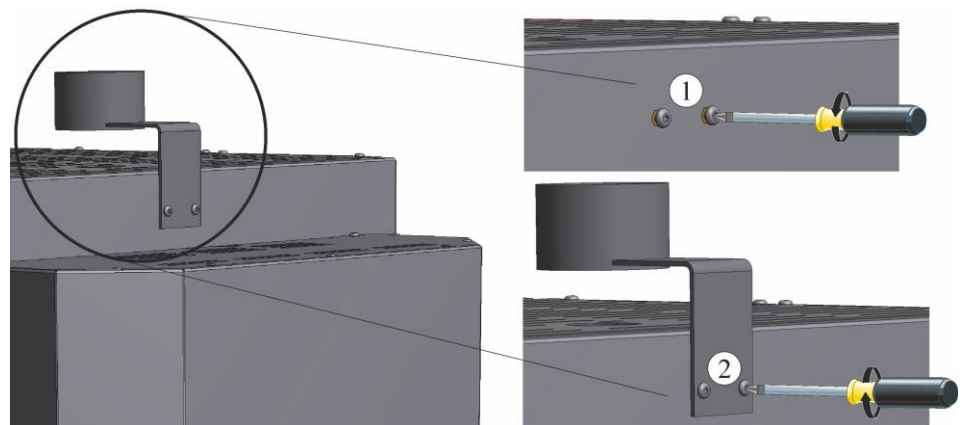


Fig. 51: Assembling the bypass connection (similar to picture)

6.2.2 Assembling the Air Inlet Flap After Assembling the Frame (N 100(H)(14)(G) – N 300(H)(14)(G))

When the furnace has been carefully placed on the frame (1) and has been secured in place with the screws, the air inlet flap can be installed under the floor of the furnace (see Installation (Furnace Location) – Installing the Frame if not Installed).

To protect the air inlet flap during transportation, it is inserted into a bracket on the rear wall.

Carefully remove the air inlet flap from the bracket on the rear wall (2).

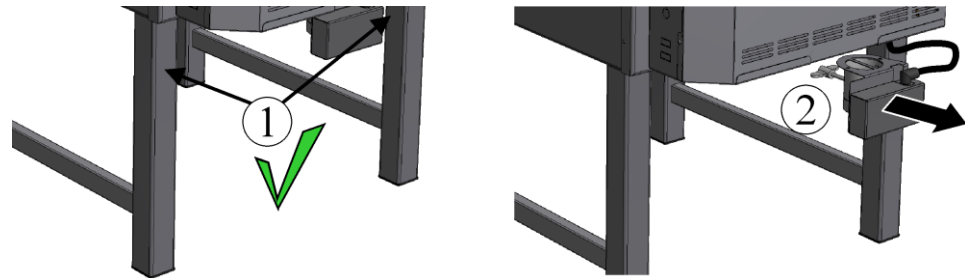


Fig. 52: Remove the bracket from the air inlet flap (similar to picture)

Where the air inlet flap is to be installed, there are screws (3) to fasten the air inlet flap that first have to be undone (the quantity and position of the screws depend on the furnace model).

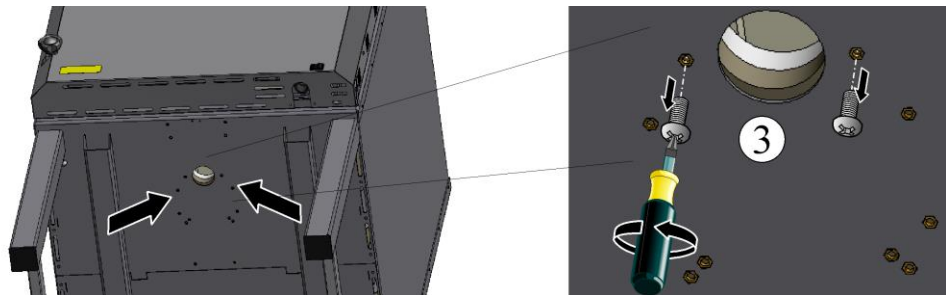


Fig. 53: Undo the screws of the air inlet flap (similar to picture)

Place the air inlet flap with the screws at the correct position on the furnace floor and fasten with a suitable tool. Check that the connection (screws) between the air inlet flap and the furnace floor is firm.

Then install the cable that runs between the air inlet flap and the rear wall in the pre-assembled cable supports (the number of cable supports depends on the furnace model).

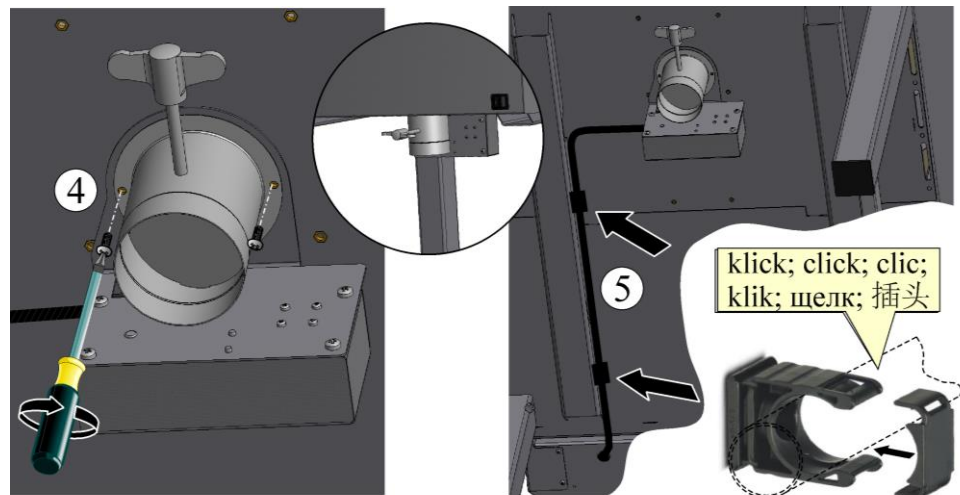


Fig. 54: Assembling the air inlet flap and installing the cable (similar to picture)

6.2.3 Place the Controller in the Holder on the Furnace (model-related)

Place the controller in the holder on the furnace.

Make sure that the controller is placed correctly in the holder. If this is ignored, the controller may be damaged or destroyed. Nabertherm accepts no liability if the controller is not handled properly.



Fig. 55: Place the controller in the holder on the furnace (similar to the picture)

The controller can simply be removed from the holder for especially ergonomic handling and more comfortable operation.

6.2.4 Exhaust Air

As a result of the process, harmful gases (exhaust gas) and high volumes of air at high temperatures (exhaust air) may be emitted to the environment.

The operator must remove the exhaust gases and exhaust air from the installation location in a suitable manner so that there are no risks for persons, property, or the building.



Warning – Fire danger

If the hot exhaust air is not removed adequately (cooling phase, for example), there is a risk of fire at the installation location and the furnace may be damaged.



Warning – Poisoning and suffocation hazard

If the exhaust gases are not removed adequately, there is a risk of poisoning or suffocation.

High thermal loads in the environment must be removed through constructional measures. High thermal loads can occur even when the furnace is closed. In addition to the exhaust air, the exhaust hood (accessory) also removes a large volume of the waste heat from the furnace. The thermal load in the room is dependent on how the furnace is operated. When the furnace is closed, this will be about 30% of the heat output of the furnace. The exhaust hood also acts as a touch guard for hot areas near the exhaust air outlet.

The exhaust air can be extracted passively through the natural draft of the downstream piping or actively through the customer's extraction system (a fan, for example).

Passive or active extraction must be able to handle the airflows and temperatures that occur. There must be no blockage or backflow in the direction of the furnace.

Constructional requirements, high exhaust air volumes, and high thermal loads may require the use of active extraction.

When the exhaust air piping is being designed, local and national regulations must be observed.

Certain emissions to the environment may be restricted by local and national regulations and additional technical measures may be required. The operator must examine the regulations.



Malfunction and operating error

Exhaust gases must be removed from the installation location in a suitable manner so that there can be no hazards for people at the location in the event of a malfunction or operating error.



Note

Specialist companies should dimension and install the exhaust air system and carry out roofing and masonry work.

6.2.4.1 Exhaust Air Control without Ducting

Reliable removal of harmful gases is not ensured without direct extraction through a ducting system. If the furnace is operated without exhaust ducting, make sure that the installation location is well ventilated and that the exhaust air is removed.



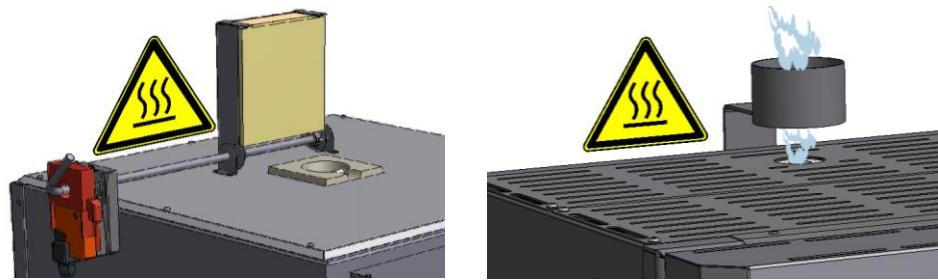
Note

The installation location of the furnace must be well ventilated when the furnace is operating.



Warning – Hot surface

Very high surface temperatures can occur at the exhaust air openings of the furnace.



Exhaust-air flap/s

Bypass connection

Fig. 56: Exhaust air (depending on model - similar to picture)

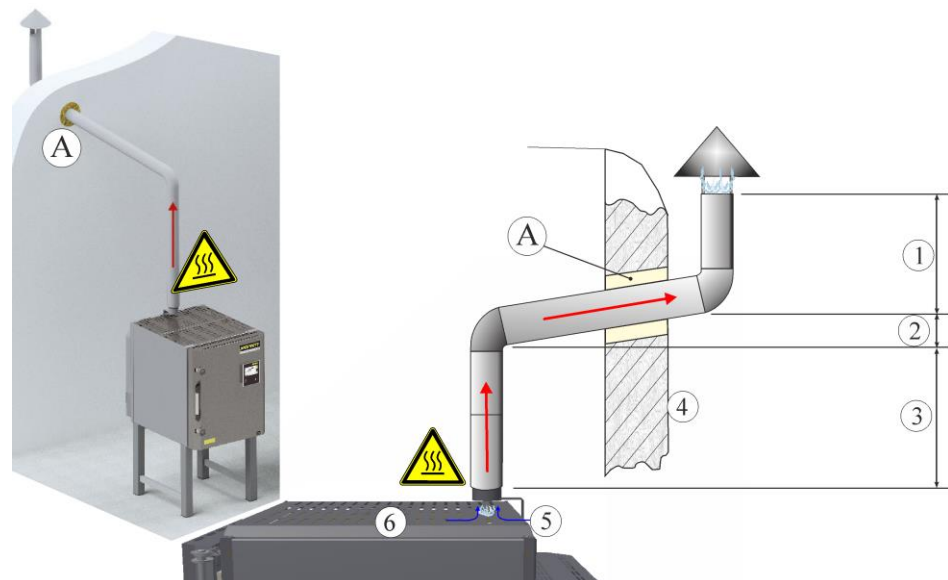
6.2.4.2 Exhaust air control with piping

Recommendations for passive ducting for models with bypass connection

The exhaust is removed through the natural draft of the ducting. A metal pipe with nominal width 80 mm can be used. The material must be corrosion-resistant and be suitable for the temperatures. It must be attached facing upwards and be fixed to the wall or ceiling.

High temperatures occur at the furnace outlet (5). With the bypass effect, cold air is added to the exhaust air of the furnace at this point. A maximum exhaust air temperature of approx. 200 °C can be assumed for the ducting. There is a risk of burning at the outlet and the ducting.

Make sure that the wall opening (A) complies with fire safety regulations. A collection device in the ducting prevents rain and condensation flowing back towards the furnace.



1 min. 1 m / 2 install rising (min. 8°) / 3 min. 0.5 m / 4 outer wall / 5 bypass effect / 6 furnace

Fig. 57: Example: Installing exhaust air piping (similar to picture)

For the exhaust air to be removed properly via natural draft, the following must be considered:

- Wind pressure, furnace and outdoor temperatures have a lot of influence on the function.
- Unfavorable pressure conditions, such as additional extraction systems at the installation location, reduce or prevent the function. Backflows must be prevented. If

the system is installed in a “passive house”, it must be ensured that the pressure conditions to the outside are balanced, such as with forced ventilation of the rooms.

- The pipe cross-sections must be adequately dimensioned.
- Adequate pipe lengths outside the building (1). Longer vertical pipe sections support the function.
- Long horizontal pipe sections (also sloping ones) and elbows reduce the function.
- Driving rain and condensation must be considered.

Recommendations for active ducting for models with bypass connection

Guide value for the volumetric flow rate to be handled at the bypass connection (5): 25m³/h. The extraction system must be suitable for the temperatures. The same recommendations apply as for an exhaust air system with passive ducting.

Recommendations for ducting for furnaces with exhaust air hood and fresh-air fan

When dimensioning the exhaust air system, the following must be considered:

- Volumetric flow rate and temperature of the exhaust air
- Constructional conditions, pipe lengths, and number of elbows
- Permissible temperatures and corrosion resistance of the exhaust air system
- Hazards caused by malfunctions or operating errors with the furnace or the exhaust air system, such as fire hazards
- Pressure conditions at the installation location
- Driving rain and wind pressure at the outlet of the pipe
- It must be easy to separate the exhaust hood and the piping for maintenance and cleaning purposes
- The building must be able to handle the weight of the piping. The exhaust hood is not suitable for bearing the weight of the piping.

Condensate deposits should be avoided. Certain condensates can cause additional hazards (such as fire hazards) or can damage the furnace. Condensate deposits can be prevented with insulation, collection systems, maintenance flaps, and regular cleaning.

Due to the high volumetric flow rates, passive removal of the exhaust air in connection with the cooling function of the furnace is possible only under ideal conditions. For the exhaust air to be removed properly via natural draft, the following must be considered:

- Wind pressure, furnace and outdoor temperatures have a lot of influence on the function.
- Unfavorable pressure conditions, such as additional extraction systems at the installation location, reduce or prevent the function. Backflows must be prevented. If the system is installed in a “passive house”, it must be ensured that the pressure conditions to the outside are balanced, such as with forced ventilation of the rooms.
- The pipe cross-sections must be adequately dimensioned.
- Adequate pipe lengths outside the building (1). Longer vertical pipe sections support the function.
- Long horizontal pipe sections (also sloping ones) and elbows reduce the function.
- Driving rain and condensation must be considered.

Active extraction (for example a fan in the piping) enables targeted removal of the exhaust air and also removes some of the waste heat from the furnace.

If several furnaces are operated on the exhaust air system, the air volumes at the removal points of the furnace can be influenced by the operating conditions. The extraction system must be able to handle the entire air volumes from the furnace at all times.

Adjustable throttle valves at the removal points allow precise adjustment of the volumetric flow rate.

High underpressure beneath the exhaust hood has an effect on natural cooling without using the fresh-air fan. Very high underpressures can have an effect on the temperature distribution inside the furnace.



Fig. 58: Example of an active extraction system (illustration is model-related)



Malfunctions and operating errors with the exhaust air system

When the furnace is in operation, the extraction must function perfectly.

Before and after the process, high temperatures may occur and the atmosphere inside the furnace may be polluted. Therefore, the exhaust air system must be operated in relation to the status inside the furnace.

A breakdown of the exhaust air system must not cause additional hazards. For the event of malfunctions, appropriate behavioral rules and measures must be defined, such as emergency ventilation of the room, switching off the furnace, special fire safety measures.

The air that is removed from the room by the exhaust air system must be replenished by a ventilation system.

Volumetric flow rates and temperatures

The interfaces to the room and the ducting are described below.

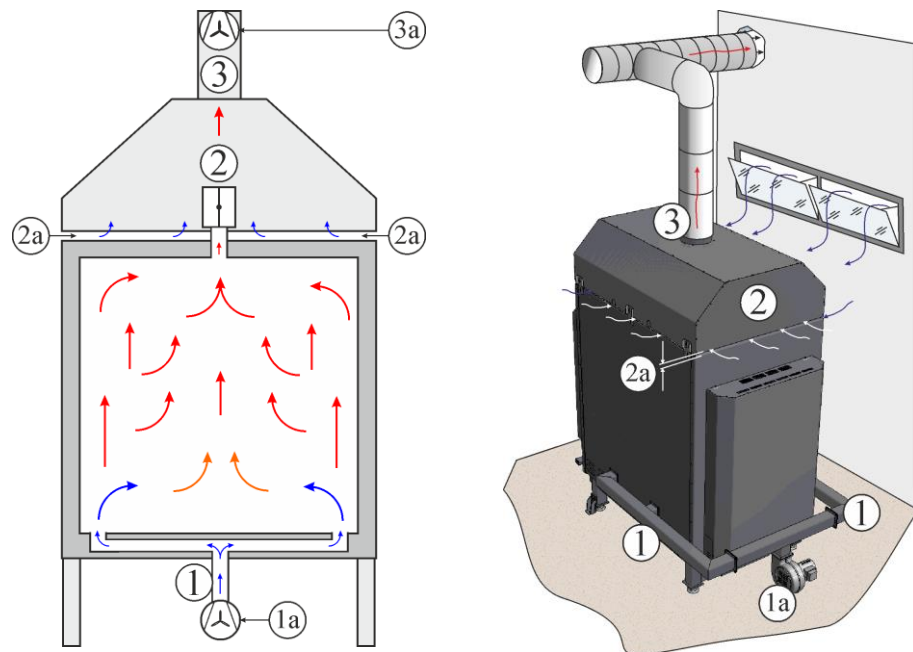


Fig. 59: Furnace with fresh-air fan, exhaust air flap, and exhaust hood (similar to picture)

Fresh-air inlet (1)

Depending on the furnace model, fresh air can be fed to the furnace chamber in different ways. Opening the bottom slide or the fresh-air flap causes air to flow through the furnace. The volumetric flow rate is low and is dependent on the temperature and how exhaust air is removed downstream from the furnace.

A fresh-air fan (option) considerably increases air flow through the furnace. In the cooling function, the volumetric flow rate can be constant or can be variable in relation to the temperature. As the temperature falls, the volumetric flow rate of fresh air generally increases to achieve the required cooling.

Exhaust air flap/exhaust hood (2)

When the exhaust air flap is opened, this creates an exchange of air with the furnace atmosphere.

Use of the fresh-air fan above 800 °C is not recommended. Therefore, this temperature can be used for general dimensioning. However, due to special requirements with regard to the process or because of an operating error, malfunction in the furnace or extraction system, high temperatures up to the maximum temperature can occur. From a technical aspect, the following components must be able to handle the process requirements. In case of an operating error or malfunction, the exhaust air system must not cause any additional hazards.

The current temperature of the furnace can be expected near the outlet (2). At a furnace temperature of 20 °C, the volumetric flow rate of the fresh-air fan (1) can be expected at (2). The volumetric flow rate varies in relation to the temperature inside the furnace. An exhaust hood (accessory) allows cold air to be added (2a).

Flange exhaust hood (3)

The mixture of the two volumetric air flows produce a mixed temperature at the flange of the exhaust hood (3). The handling capacity of the customer's exhaust air system (3a) and the adjustable gap on the exhaust hood (2, 2a) influence the mixed temperature that has to be dimensioned for the following components. The lower the permitted temperature of the

exhaust air system, the higher the volumetric flow rate required for cooling the exhaust hood. The total of the volumetric flow rates from the furnace (2) and (2a) is the volume that the exhaust air system must be capable of handling.

Dimensioning data for exhaust air (guidelines)			
All volumetric flow rates in m ³ /h based on 20 °C (unexpanded air)			
Volumetric flow rate at 20 °C			
Furnace chamber temperature 800 °C			
Control variable for fresh-air fan 100% at 800 °C (operating error / special case)			
Furnace model	① Volumetric flow rate of fresh-air fan	③ Volumetric flow rate flange exhaust hood = Σ Volumetric flow rates = (2) + (2a)	
		Example Tmax exhaust air system 120 °C	Example Tmax exhaust air system 400 °C
NE 100 – NE140	max. 40 m _N ³ /h	approx. 320m ³ /h	approx. 85 m ³ /h
N 100 – N 660 (A25)	max. 40 m ³ /h	approx. 320m ³ /h	approx. 85 m ³ /h
N 100 – N 660 (D05)	max. 300 m ³ /h	approx. 2200m ³ /h	approx. 630 m ³ /h
NW 150 – NW 440 (A25)	max. 40 m ³ /h	approx. 320m ³ /h	approx. 85 m ³ /h
NW 150 – NW 660 (D05)	max. 300 m ³ /h	approx. 2200m ³ /h	approx. 630 m ³ /h
NW 1000	max. 750 m ³ /h	Not applicable	approx. 1580 m ³ /h
N1000- N2200	max. 750 m ³ /h	Not applicable	approx. 1580 m ³ /h

Fig. 60: Dimensioning data for exhaust air

6.2.4.3 Installing the Exhaust Hood(s) (Accessories)



When the furnace is delivered, remove the packaging materials. The exhaust hood/s must be visually checked for damage. We recommend that at least two or more persons perform the work of transporting and installing.

Protective gloves must be worn when installing the exhaust hood/s.

The danger of falling is still present (from the roof of the furnace, from the ladder or from the scaffolding). Observe the occupational safety regulations of the respective country of installation.

	DANGER
	<ul style="list-style-type: none"> • It is not allowed to walk on the furnace roof. • There is a risk of it caving in. • Components can break or be damaged if they are walked upon.

When positioning the exhaust hood make sure the orientation is correct. Position the cut-out of the exhaust hood on the side of the shaft (1) of the exhaust-air flaps (if included).

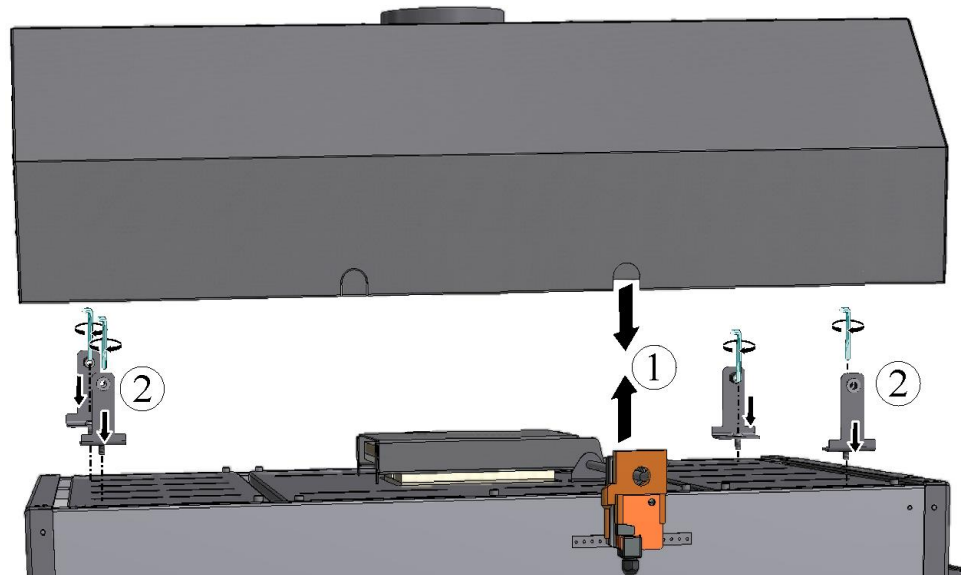


Fig. 61: Example: Positioning the exhaust hood/s (similar to picture)

The screws (2) for fixing the exhaust hood(s) are on top of the furnace. Position the exhaust hood(s) where the installed screws are located. The number and position of the screws may differ depending on the model. The exhaust air flap(s) beneath the exhaust hood(s) must be able to move freely

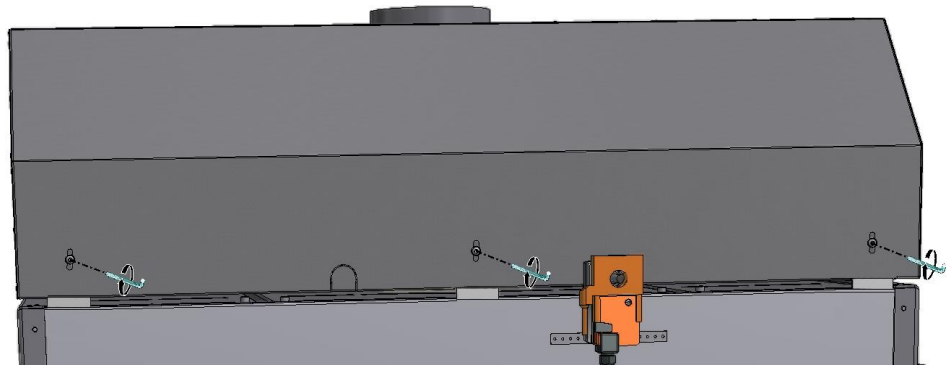


Fig. 62: Example: Positioning and fastening the exhaust hood/s (similar to picture)



Installing the piping

The exhaust hood is not suitable for bearing the weight of the piping. It should be easy to separate the piping from the exhaust hood for adjustment and maintenance work.

6.2.4.4 Setting the Height of the Exhaust Hood

When the fresh-air fan (if present) is switched on, the pressure below the extraction hood (if present) should always be slightly lower than the ambient pressure. Therefore, with active extraction, the extraction capacity should be adjustable (e.g. with a throttle valve). A mixed volumetric flow rate is adjustable through the distance (2) between exhaust hood and the furnace.

The height of the exhaust hood can be adjusted steplessly with the screws (1) on the all-round brackets. Make sure that there is an even gap between the exhaust hood and the furnace.

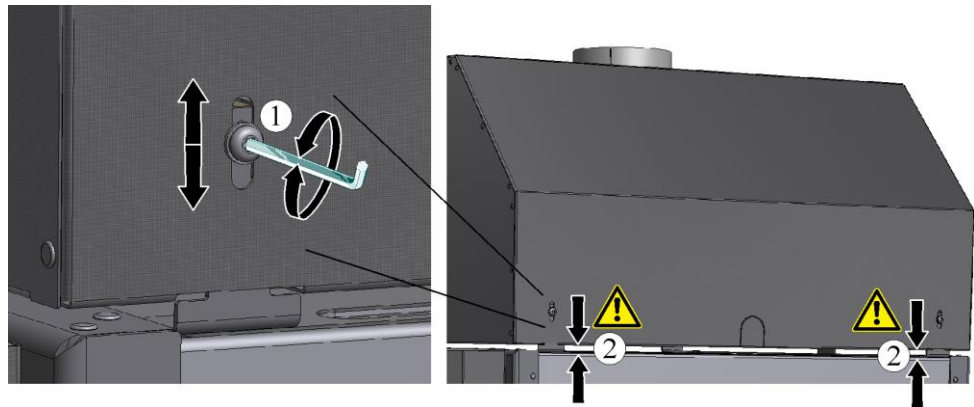


Fig. 63: Setting the height of the exhaust hood (similar to picture)



Warning – Fire danger

If the hot exhaust air is not removed adequately (cooling phase, for example), there is a risk of fire at the installation location and the furnace may be damaged.

6.2.5 Connecting the Furnace to the Power Supply

The customer must ensure that the floor has adequate load-bearing capacity and that the necessary energy (electricity) is provided.

- The furnace must be installed according to its intended use. The power connection must correspond to the values on the furnace type plate.
- The power socket must be close to the furnace and be easily accessible. The safety requirements are not met if the furnace is not connected to a socket with a protective ground contact.
- For all furnace models with a plug-in connection, ensure that the distance between the circuit breaker and the power socket that the furnace is connected to is as short as possible, NO power board or extension cable is used between the power socket and the furnace.
- The power cable must not be damaged. Do not place any objects on the power cable. Lay the cable in such a way that no one can stand on it or trip over it.
- Power cables may be replaced only with similar, approved cables.



Note

Before connecting the power, make sure that the power switch is set to "Off" or "0".

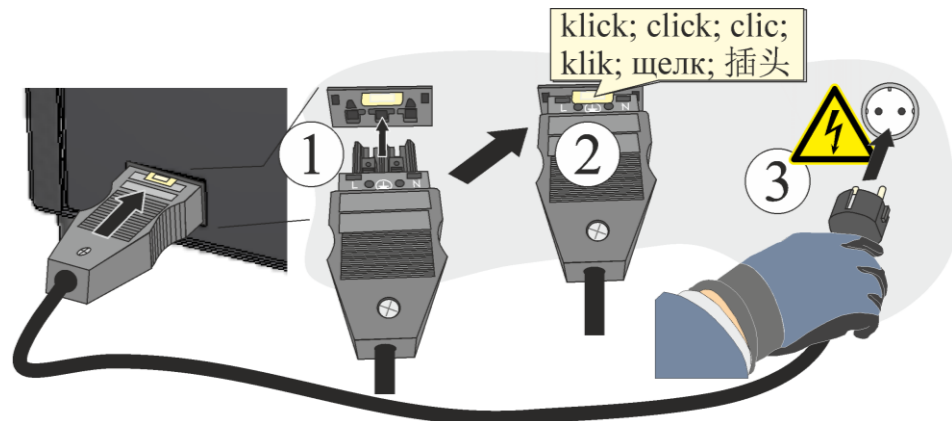


Fig. 64: Furnace up to 3600 kW (the power cable is supplied) (similar to picture)

1. Plug the supplied connection cable with snap-in coupling into the rear wall of the furnace.
2. Then connect the power cable to the power supply. Use only a grounded socket.

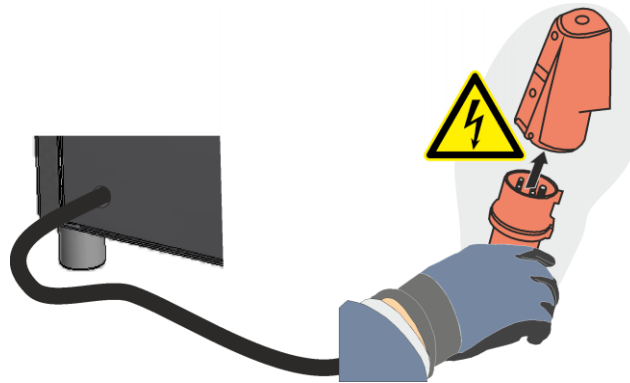


Fig. 65: Furnace from 3.600 W (CEE plug) (similar to picture)

1. Connect the power cable to the power supply. Use only a grounded socket.
Check the ground resistance (acc. to VDE 0100); see also accident prevention regulations.
Electrical systems and equipment according to DGUV V3.

Power Connection without Plug-In Power Line:

The power line must have a fixed connection in the switchgear cabinet, either at the available terminals or, in models without a separate switchgear, to the main switch. When carrying out this work pay attention to the specs on the type plate: network voltage and type, and maximum power consumption.

The fuse protection and the cross-section of the required power connection depend on the surrounding conditions, the length of the line and how it is installed. For this reason, the type of protection and how it should be installed must be decided by a qualified electrician.

- The power cable must not be damaged. Do not place any objects on the power cable. Lay the cable so that nobody can step on it or trip over it.
- The power line may only be replaced by an approved, equivalent line
- Ensure that the connection line of the furnace is protected

This protection must be compliant with locally applicable standards and regulations.

Ensure that the protective conductor terminal is correct.

When several phases are involved, they must be connected with a clockwise rotating field in the sequence L1, L2, L3.

Before you switch on the furnace for the first time make sure that a **clockwise rotating field is in place**. This is a prerequisite for the smooth functioning of the furnace.



Warning – Danger of Electric Shock!

Work on the electrical equipment may be done only by qualified, authorized electricians.

The customer must supply the necessary preconditions such as the load-bearing capacity of the bearing surface and a source of electric power.

- Make sure that the power lines are adequately dimensioned and secured corresponding to the furnace's parameters.
- Ensure that the connection line to the furnace/switchgear is protected.
- A residual current circuit breaker (RCCB) cannot be used with the following components.
- Testing of the earth resistance (compliant with VDE 0100); see also the accident prevent regulations.
- Electric facilities and operating equipment compliant with DGUV V3.

See the enclosed circuit diagram for the wiring and electrical connections. The machine's electrical equipment is shown in the circuit diagram.

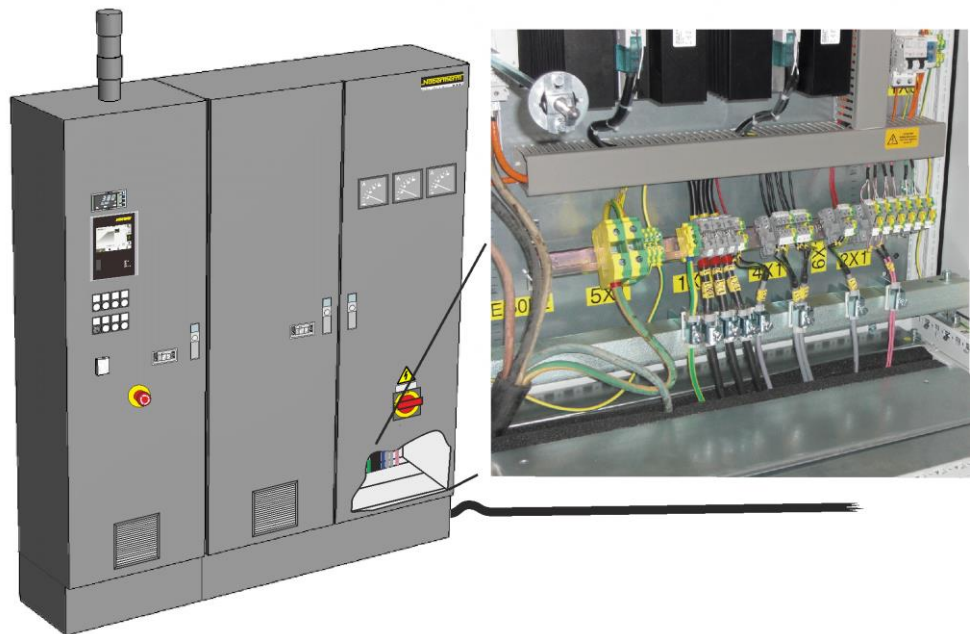



Fig. 66: Example: Power connection (similar to picture)



Note

The national regulations of the respective country of operation apply.

	CAUTION	<ul style="list-style-type: none"> Danger from incorrect voltage Damage to the device Check voltage before connecting and starting the furnace Compare the voltage with the details on the type plate 	<table border="1" style="width: 100%; border-collapse: collapse;"> <tr> <td colspan="2" style="text-align: right; font-weight: bold; font-size: small;">Nabertherm</td> </tr> <tr> <td colspan="2" style="font-size: x-small;">Nabertherm GmbH Bahnhofstr. 20, 20065 Löhndorf/Steinm., Germany Tel: +49 (0)4298 922-0, Fax: +49 (0)4298 922-129 contact@nabertherm.de www.nabertherm.com</td> </tr> <tr> <td style="width: 50%;"></td> <td style="width: 50%; text-align: right;"> Made in Germany CE </td> </tr> </table>	Nabertherm		Nabertherm GmbH Bahnhofstr. 20, 20065 Löhndorf/Steinm., Germany Tel: +49 (0)4298 922-0, Fax: +49 (0)4298 922-129 contact@nabertherm.de www.nabertherm.com			Made in Germany CE
	Nabertherm								
Nabertherm GmbH Bahnhofstr. 20, 20065 Löhndorf/Steinm., Germany Tel: +49 (0)4298 922-0, Fax: +49 (0)4298 922-129 contact@nabertherm.de www.nabertherm.com									
	Made in Germany CE								

6.2.6 Initial Start-Up

Read the section on "Safety". When the furnace is put into operation, the following safety information must also be observed to prevent serious injury, damage to the furnace, and damage to other property.

Make sure that the instructions and information in the instruction manual and the controller instructions are observed and followed.

Before starting the furnace for the first time, make sure that all tools, foreign parts, and transportation securing equipment have been removed.

Before you switch on the furnace, make sure that you know what to do in case of faults or emergencies.

Before placing materials in the furnace, check whether they could harm or destroy the insulation or the heating elements. Materials that could damage the insulation include: alkalis, alkaline earths, metal vapors, metal oxides, chlorine compounds, phosphorous compounds, and halogens. **If applicable, read the labels and instructions on the packaging of materials that you use.**



Note

Before starting the furnace for the first time, allow it to acclimatize at its installation location for 24 hours.

6.2.7 Recommendations for Heating Up the Furnace for the First Time



Heat the kiln to dry out the insulation and to get a protective oxide coating on the heating elements. The life of the heating elements is dependent on obtaining a good oxide coating. There may be some unpleasant odors while the kiln is heating. This is due to binder being emitted from the insulation material. It is advisable to ventilate the room in which the kiln is located well during the first heating phase.

- Half open the air inlet valve/flap (see "Operation")
- Close the door (see "Operation")
- Switch on the furnace/controller with the power switch (see "Operation")
- Open the exhaust air flap (if present) (see "Operation")
- Heat the empty furnace or furnace containing new furniture (for example batts and props).
- Use "Program 01" from the pre-set programs the first time you heat up the kiln.
- **For furnaces with Tmax. 1400 °C (2552 °F), the following heating program should be carried out without furniture.**
 - Heat the empty furnace to 1100 °C (2012 °F) over 10 hours, keep it at this temperature for 12 hours and then let it cool naturally.
- Read the controller instructions for how to enter temperatures and times.
- After the heating phase, allow the kiln to cool naturally.

The insulation materials and furniture have a natural residual moisture. During the first firings, condensation may accumulate and drip from the housing.



Fig. 67: Condensation accumulations during the first firings (similar to picture)

Program 01

Program name: First firing (“FIRST FIRING”)

Segment	Start	Target	Time	Fresh-air valve	Comments
1	0 °C	500 °C	360 min	The air inlet flap must be completely open	
2	500 °C	900 °C	180 min		
3	900 °C	900 °C	240 min		
					Allow the furnace to cool naturally (keep the door closed).

¹ Air inlet flap us opened and closed manually

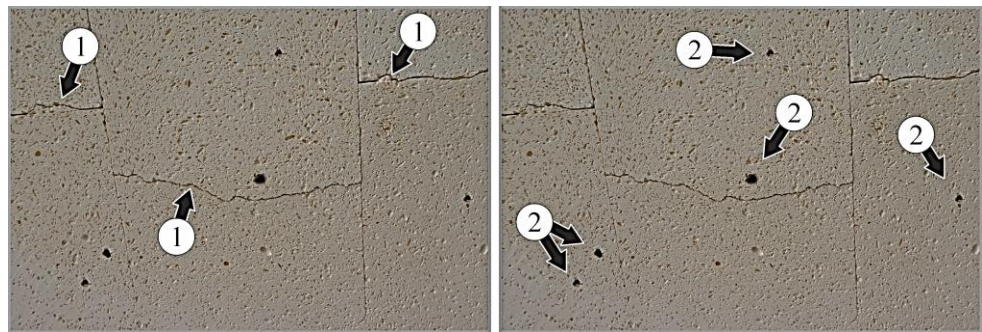
² The furnace is heated to the set temperature as quickly as possible.

³ In the case of furnaces with a semi-automatic air inlet flap, the flap is closed when the extra function (Extra 1) is activated.

⁴ In the case of furnaces with an automatic air inlet flap, the flap is opened when the extra function (Extra 1) is activated.

Insulation

The furnace insulation is made from high-grade fireproof material. Due to thermal expansion, cracks in the insulation will occur after a few heating cycles. These have no influence on the function, safety or quality of the furnace. The refractory bricks (insulation) are of a particularly high quality. Due to the manufacturing process small holes or cavities may occur. These are quite normal and underline the quality features of the bricks. These holes or cavities are not a reason for complaint.



Cracks

Cavities

Fig. 68: Example: Cracks (1) and cavities (2) in the insulation after just a few heating cycles (similar to picture)

Note

Continuous operation at maximum temperature can lead to increased wear of heating elements, insulation materials and metallic components. We recommend working at approx. **50 °C below maximum temperature**.

Note

New kiln furniture (e.g. shelves and props) should be heated once to dry them out (as described above). When cold, heating elements are extremely brittle. Take great care when filling, emptying and cleaning the furnace.

The door must be locked during firing. To extract emitted gases and vapors more quickly and to shorten the cooling phase after firing, the air inlet valve or flap (model-related) can be completely or partially opened.

7 Operation

7.1 Controller

B500/C540/P570



Fig. 69: Control field B500/C540/P570 (similar to picture)

No.	Description
1	Display
2	USB interface for a USB stick



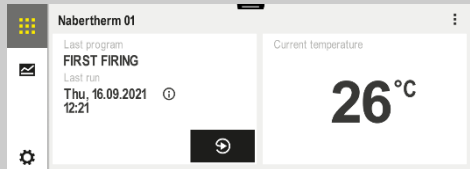
Note

See the separate operating instructions for a description of how to enter temperatures and times and to “start” the furnace.

7.2 Operation, Display and Switch Elements (depending on design)

7.2.1 Turning on the Controller/Furnace

Turning on the controller		
Procedure	Display	Comments
Turn on the power switch		Set power switch to “I”. (Power switch type varies according to design/furnace model)


Turning on the controller		
Procedure	Display	Comments
<p>The furnace status is displayed. After a few seconds, the temperature is displayed.</p>		<p>When the temperature is shown on the controller, the controller is ready for operation.</p>



Note

Continuous operation at maximum temperature can lead to increased wear of heating elements, insulation materials and metallic components. We recommend working at approx. **50 °C below maximum temperature.**

7.2.2 Turning off the Controller/Furnace

Turn off the controller		
Steps	Display	Comments
<p>Turn off the power switch</p>		<p>Turn off the power switch by setting it to "O" (power switch type differs depending on features/furnace model)</p>



All the necessary settings for perfect functions have already been made at the factory.

Note

Make sure that the doors of the control box are always locked and bolted. Otherwise dirt can be expected to shorten the useful life of the installed electrical switching components.

7.2.3 Accessing Extra Functions (Extra 1 and Extra 2) via the Controller

During a heat treatment program, you can call up special functions via the programming of the extra relay. Depending on the required function (see table), the extra relays are set in the corresponding segment during programming and are activated automatically while the program is running:

Air inlet flap control via extra function 1 (standard)

Extra 1	Extra 2	Function
x	-	Closing of air inlet flap
-	-	

Air inlet flap/exhaust air flap control via extra function 1 and 2 (standard plus1)

Extra 1	Extra 2	Function
x	-	Closing of air inlet flap
-	x	Opening/closing of exhaust air flap

Exhaust air flap control in combination with cooling fan via extra function 1 and 2 (standard plus2)

Extra 1	Extra 2	Function
x	-	Opening/closing of exhaust air flap
-	x	Switching on and off of the cooling fan

Exhaust air flap/small cooling fan control via extra function 1 and 2 (accessories)

Extra 1	Extra 2	Function
x	-	Opening/closing of exhaust air flap
	x	Switching on and off of the cooling fan
x	x	Opening/closing of exhaust air flap and Switching on and off of the cooling fan

Exhaust air flap/air inlet flap/small cooling fan control via extra function 1 and 2 (accessories)

Extra 1	Extra 2	Function
x	-	Opening/closing of exhaust air flap
	x	Opening/closing of air inlet flap and Switching on and off of the cooling fan
x	x	Opening/closing of the exhaust air flap , Opening/closing of air inlet flap and Switching on and off of the cooling fan

Exhaust air flap/large cooling fan control via extra function 1 and 2 (accessories)

Extra 1	Extra 2	Function
x	-	Opening/closing of exhaust air flap
x	x	Opening/closing of exhaust air flap and Switching on and off of the cooling fan

Exhaust air flap/air inlet flap/large cooling fan control via extra function 1 and 2 (accessories)

Extra 1	Extra 2	Function
x	-	Opening/closing of exhaust air flap
x	x	Opening/closing of the exhaust air flap , Opening/closing of air inlet flap and Switching on and off of the cooling fan



Note

If a large cooling fan is used, the fan can only be started when the exhaust air flap is open (there is no error message if the flap is not open).

If your furnace has a small cooling fan (ventilator), this can be started even if the exhaust air flap is closed.



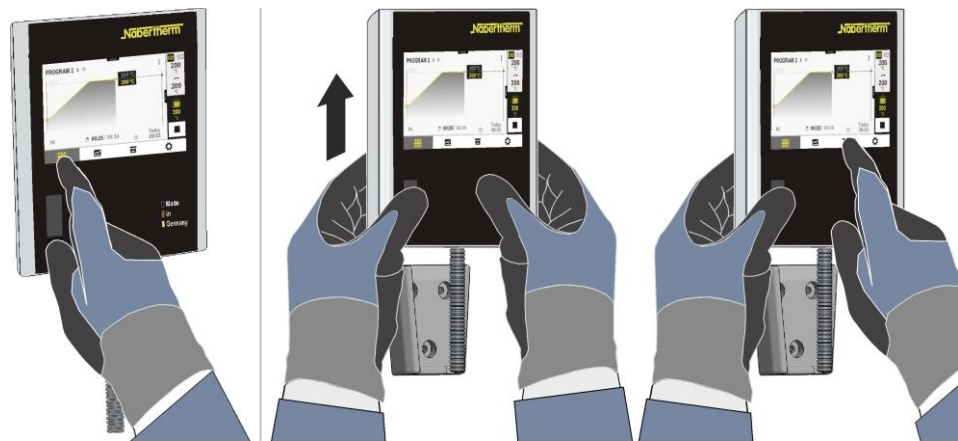
Note

For operation and instructions consult the operating instructions for your controller.

7.2.4 Handling the Controller

The controller can simply be removed from the holder for especially ergonomic handling and more comfortable operation.

After use, replace the controller in its holder.



Simple operation directly on the controller

Easy and ergonomic handling by removing the controller from its holder

Fig. 70: Handling the controller (similar to picture)

Make sure that the controller is placed correctly in the holder. If this is ignored, the controller may be damaged or destroyed. Nabertherm accepts no liability if the controller is not handled properly.



Fig. 71: Place the controller in the holder on the furnace (similar to the picture)

7.3 Over-Temperature Limiter with Manual Reset and Adjustable Cutout Temperature (Additional Equipment)



Fig. 72: Over-temperature limiter with manual reset (similar to picture)

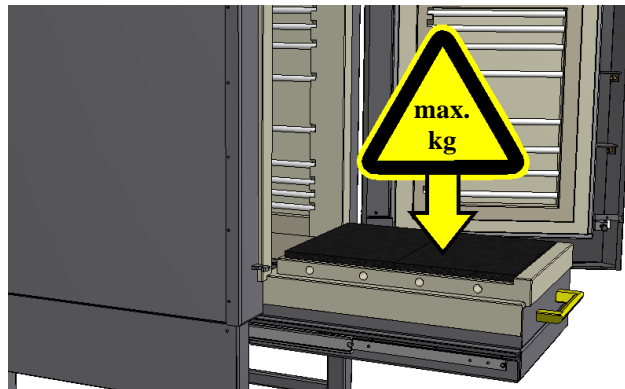
Note

See additional operating instructions for description and function.

7.4 Loading/Charging

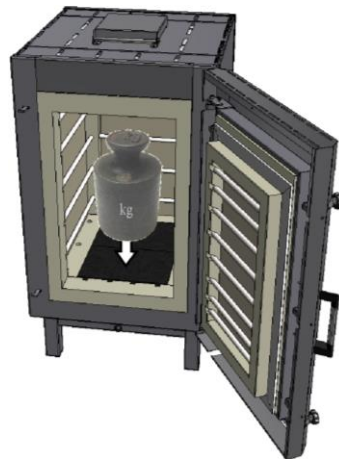
- Operate the furnace only when all safety devices and safety-related equipment, such as removable safety devices, emergency stop equipment, sound insulation, extraction equipment, are present and functioning.
- Use only materials whose properties are known. If applicable, observe the relevant safety data sheets for the materials.
- Large quantities of material in the furnace can substantially lengthen the heating-up time. If the material in the furnace is packed densely, this can affect the temperature distribution.
- When the furnace is being loaded, be sure to avoid concentrated loads (maximum 10 kg/dm²). Do not exceed the maximum charge weight.
- To ensure that the heat is removed from the floor heating chamber, do not completely cover the SiC tile.
- Depending on the required temperature distribution, position the charge at a suitable distance from the walls, floor, door and roof. Depending on the requirements, additional furniture is recommended.
- The floor insulation and the SiC floor tile are not suitable for application of an adhesive release agent, such as engobe.

- When charging the furnace with drawer (NW 150(H) – NW 300(H)) pay attention to the **maximum** charge weight. If this is ignored, Nabertherm accepts no liability for damage or injuries.



NW 150.. max. 75 kg
 NW 200.. max. 100 kg
 NW 300.. max. 150 kg

Fig. 73: Maximum charge weight (NW 150../NW 200../NW 300..)



The maximum load bearing capacity of the furnace base (filling weight) is very dependent on the temperature. We recommend approx. 50 % of the furnace volume in kg as the loading limit.

Example: N 650.. = 650 liters furnace volume (see "Specifications") corresponds to approx. 325 kg maximum load bearing capacity of the furnace base

Fig. 74: Recommendation: Maximum load bearing capacity of the furnace base

- The operator must ensure that no one can be accidentally injured while the doors or the bogie are moving. The operator must choose a working position from which he or she can see all moving parts. No one should spend time in the furnace.
- Before every start, the operator must make sure that no one is inside the furnace.
- Do not sit or stand on the pull-out drawer or bogie.
- If it can be at all avoided, do not open the furnace when it is hot. If it is necessary to open the furnace at a high temperature, the time should be kept to an absolute minimum. Wear the appropriate protective clothing and ensure adequate ventilation; see "Safety". The housing or its lining can discolor (especially if the furnace is opened while hot), but this does not impair the functionality of the furnace. We recommend that the charge be left in the furnace until it is completely cooled.
- By connecting a gas supply system (accessory) the furnace chamber can be purged with reduction gases, but a defined atmosphere cannot be achieved in the furnace. Note: There is a risk of suffocation from emitted protective gas.
- Make sure that all metal parts projecting from the furnace are grounded correctly while the furnace is operating. This may be necessary, for example, if the furnace has holes to insert thermocouples.

7.5 Driving the Bogie in and out

NW 440(H) – NW 2200(H)

After the complete opening of the swinging door, the bogie can be charged completely outside the furnace. Pull out the draw bar (1) (on the side of the furnace housing) and insert it into the holder (2) of the bogie. Pull out the bogie for charging. The bogie heater automatically connects to the power source when the bogie is driven in.

Always remove the draw bar from its holder on the bogie before closing the door and putting it back in its holder on the furnace housing.

Caution: When charging the bogie pay attention to weight distribution and the upper load limit (see section "Loading/Charging").

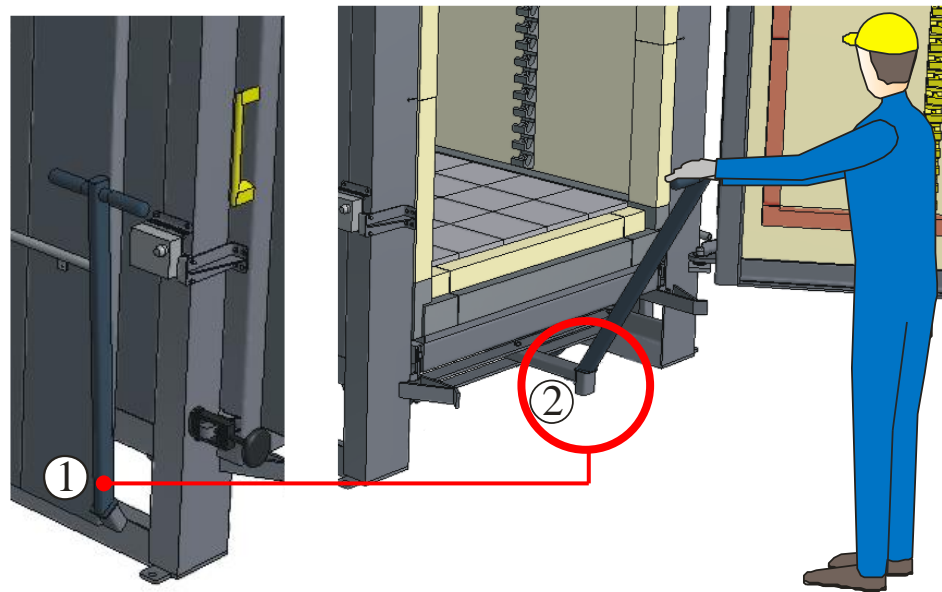


Fig. 75: Inserting the draw bar

To separate the electric contacts between the bogie and the furnace, press the **top of the pedal (A)** vigorously with your foot and pull the drawbar at the same time (see bottom figure).

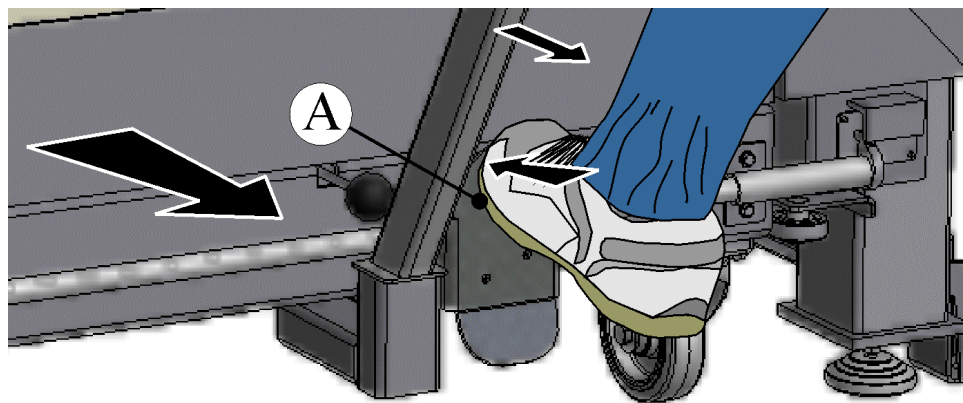


Fig. 76: Driving the bogie out (similar to the picture)

To press the bogie into the electric contacts easier (between the bogie and the furnace), first push the bogie into the furnace as far as it will go. Then, press the **bottom of the pedal (B)** vigorously with your foot. The bogie is pressed into the electric contacts (see bottom figure).

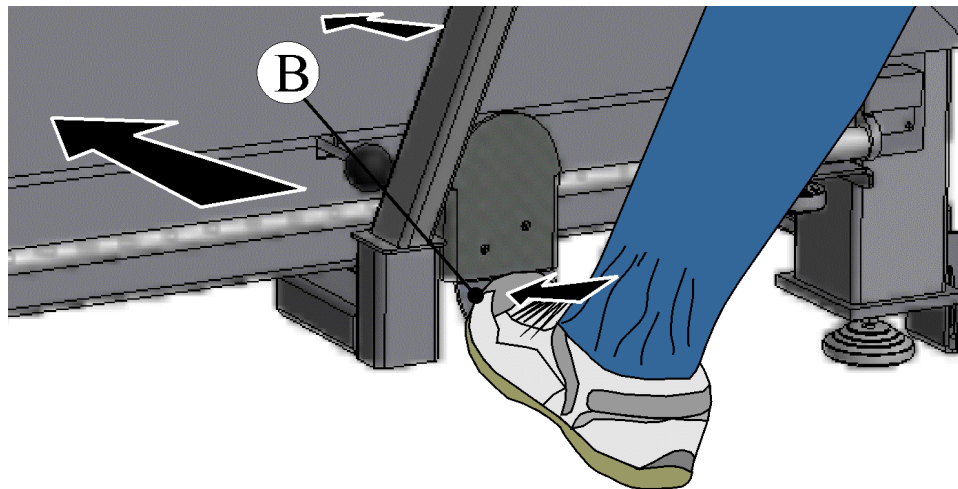


Fig. 77: Driving the bogie in (similar to picture)

7.6 Opening and Closing the Door

7.6.1 Furnace with Adjustable Quick Release

Open door (with adjustable quick release)

Open the quick release as shown in the figure below. Pull the handle lightly to open the door. It is advisable to open the door completely to fill the furnace.

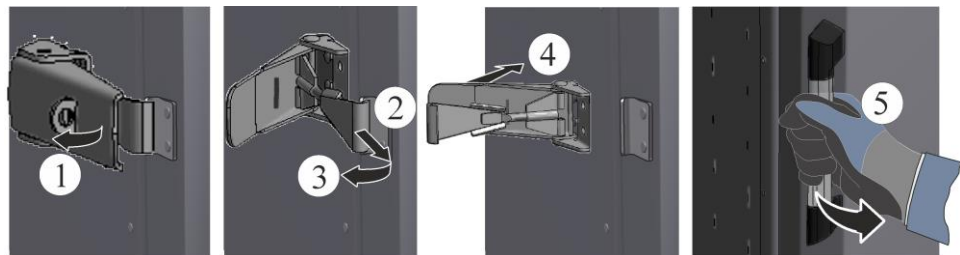


Fig. 78: Open the door (similar to picture)

Close door (with adjustable quick release)

Close the door of the furnace carefully (do not slam it shut). Close the quick release as shown in the figure below.

When the door is closed, make sure that it is closed evenly all around. Check the quick release and, if necessary, adjust the snap lock (A) with a few turns so that it can be closed effortlessly.

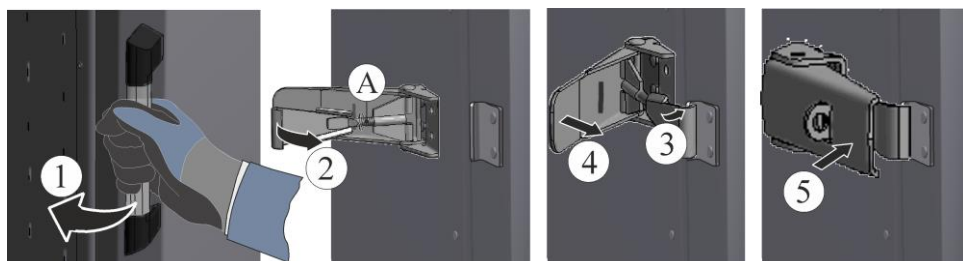


Fig. 79: Close the door (similar to picture)

7.6.2 Furnace with Quick Release (Variant A)

Opening and Closing the Swinging Door

Turning to the left, loosen locks (1) of the swinging door and swing away towards the furnace housing (2).

Pull the door handle (3) to open the swinging door. The swinging door must be fully open to charge the furnace. The door is closed in the reverse sequence. Press the swinging door carefully against the furnace collar (**do not let it swing shut**). The weight of the swinging door can cause damage to the furnace or the door collar.

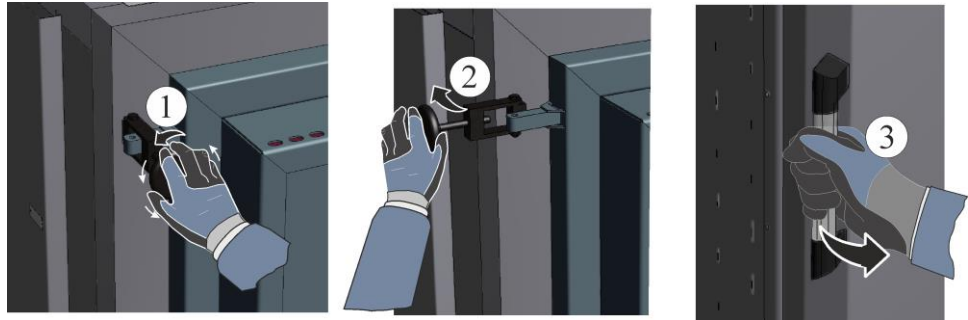


Fig. 80: Opening the swinging door (similar to picture)

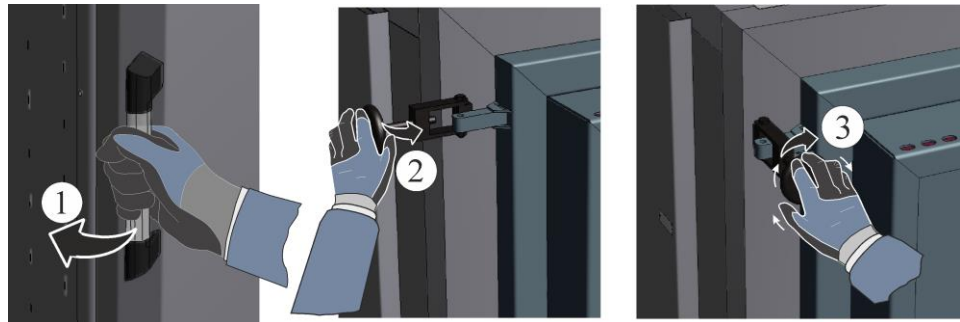


Fig. 81: Closing the swinging door (similar to picture)

7.6.3 Furnace with Quick Release (Variant B)

Opening and Closing the Swinging Door

Loosen the locks (1) on the swing door in an anticlockwise direction and swing them towards the furnace door hinges (2).

Pull the door handle (3) to open the swinging door. The swinging door must be fully open to charge the furnace. The door is closed in the reverse sequence. Press the swinging door carefully against the furnace collar (**do not let it swing shut**). The weight of the swinging door can cause damage to the furnace or the door collar.

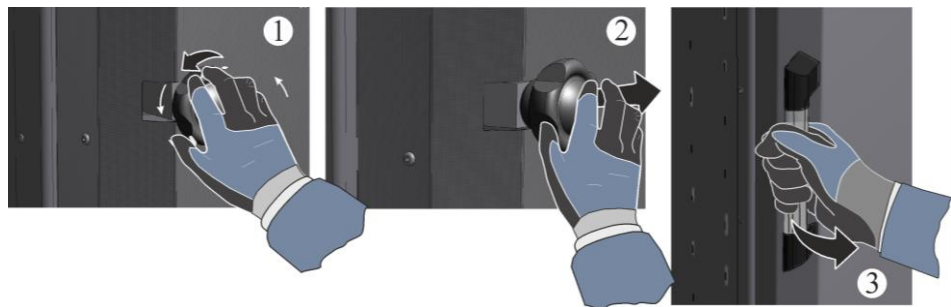


Fig. 82: Opening the swinging door (similar to picture)

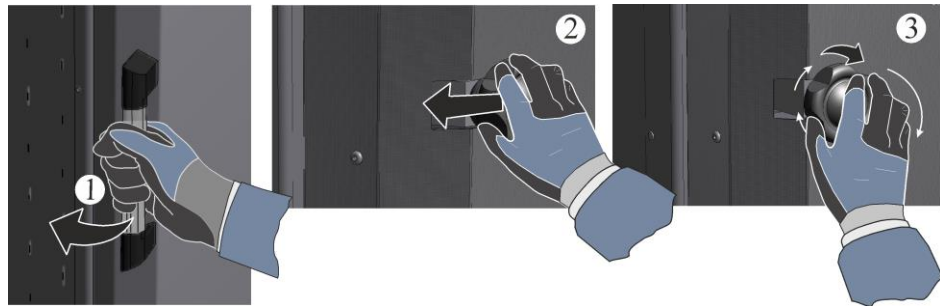


Fig. 83: Closing the swinging door (similar to picture)

7.6.3.1 Safety Star Knobs - Actuation with Key (Accessories)

The safety star knobs, prevents release through unauthorized persons. The key (1) can be folded down so that the release or tensioning is less obstructed when the key is inserted. A latching mechanism holds the key handle in the respective position.

With inserted key (2) (turning is not necessary) the normal function of a star knob (clamp/release) is given.

Without the inserted key (3), the star knob can only be clamped, i.e. it can only be turned clockwise. When turned (released) to the left, a latching mechanism interrupts the connection between the handle body and the threaded bushing.

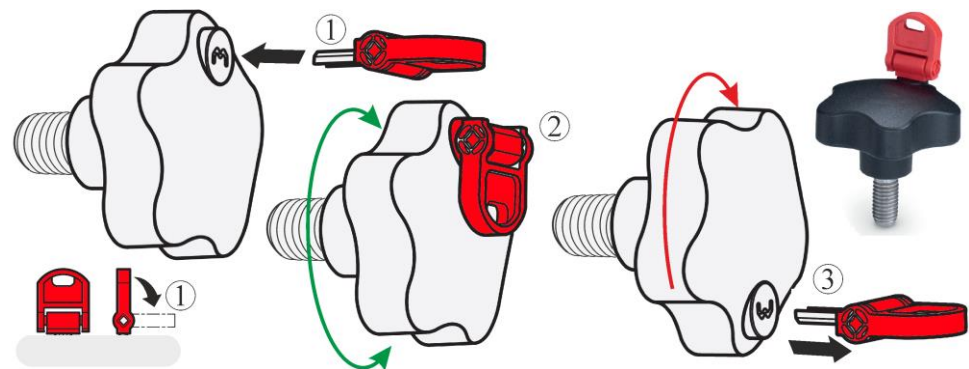


Fig. 84: Function/operation of the safety star knob (similar to picture)

7.7 Exhaust-Air Flap (Depending on the Model)

Motorized Exhaust-Air Flap(s) (additional equipment)

This furnace has (motor-driven->optional) adjustable exhaust air flap/s. Exhaust air flaps are used to extract exhaust air caused by the process safely from the furnace. The furnace is also supplied with fresh air via the air inlet valve/flap or a fresh air fan (optional).

If it is necessary only to extract the exhaust air from the furnace, and no air exchange is wanted, it is sufficient to open the exhaust air flap/s.

Constant air exchange is ensured if the air inlet valve/flap and the exhaust air flap/s are opened.

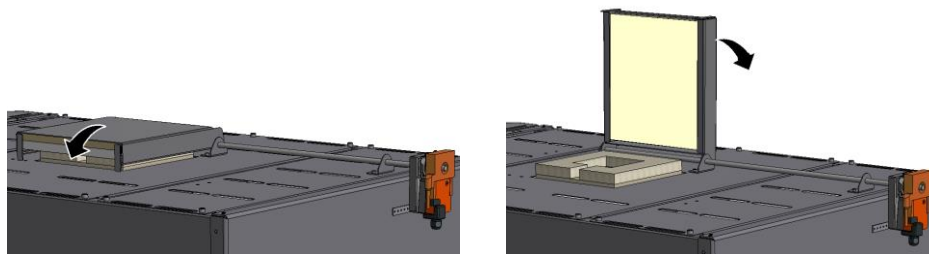
Do not open just air inlet valve/flap (or switch on a fresh air fan -> optional), as, in this case, it is not possible to generate a defined state in the furnace.

During the process, the exhaust air flap can be opened in a desired program segment via extra function 2 of the controller (see optional controller instructions).



Caution

Operating the furnace with the flaps open can change the temperature conditions in the furnace chamber. If the batch is sensitive to temperature fluctuations it may be advisable to run a test for temperature homogeneity to optimize the process.



Exhaust-air flap closed

Exhaust-air flap open

Fig. 85: Controlling the flow of exhaust air (similar to picture)



Note

Control/Regulation of the motorized actuator are described in a separate instruction manual for the switchgear

7.8 Air Inlet Valve/Flap (Model-Related)

The volume of air fed to the furnace can be adjusted with the air inlet valve or flap (model-related). The air inlet valve/flap is located on the base of the furnace.

After the chemically bound water has been expelled from the ceramics during the firing (max. 600 °C (1112 °F)), the air inlet flap or valve (model-related) of the furnace must be closed to prevent drafts and to ensure good temperature uniformity in the upper temperature range.

Alternatively, the air inlet flaps/valves can be operated with an electric drive system that is controlled fully automatically via the controller.

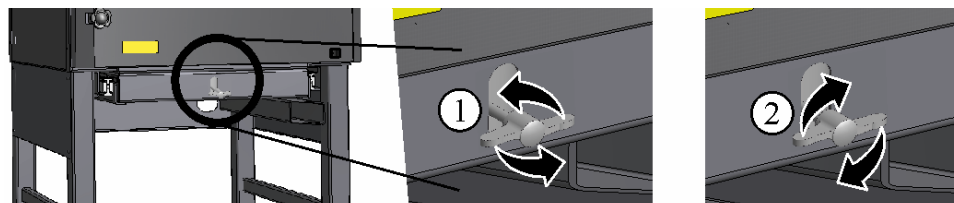
By default, the models in the chamber furnace series N 140 E(L) – N 280 E(L), N 100(H)(14)(G) – N 300(H)(14)(G) and NW 150(H) – NW 300(H) have a **semi-automatic, electromagnetic controlled air inlet flap**.

With this function it is possible to dry the ceramics at low temperatures before the actual firing begins with the air inlet flap closed (good temperature distribution in the furnace).

Before the program starts, the air inlet flap must be opened manually. During the process, the air inlet flap can be closed once in a desired program segment via **extra function 1** of the controller (see separate controller instructions). **The air inlet flap must be re-opened manually before the next firing.**

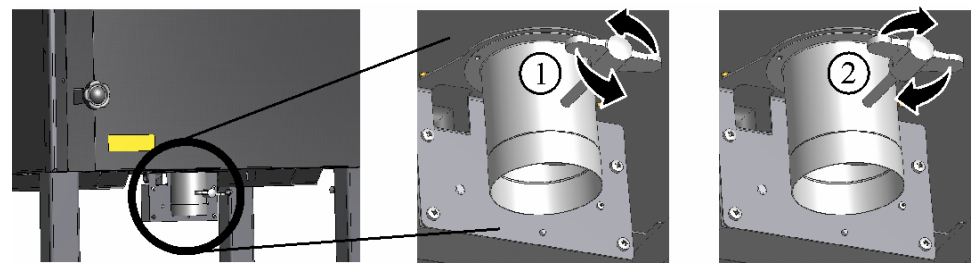
Air inlet flap

- 1 = close
- 2 = open



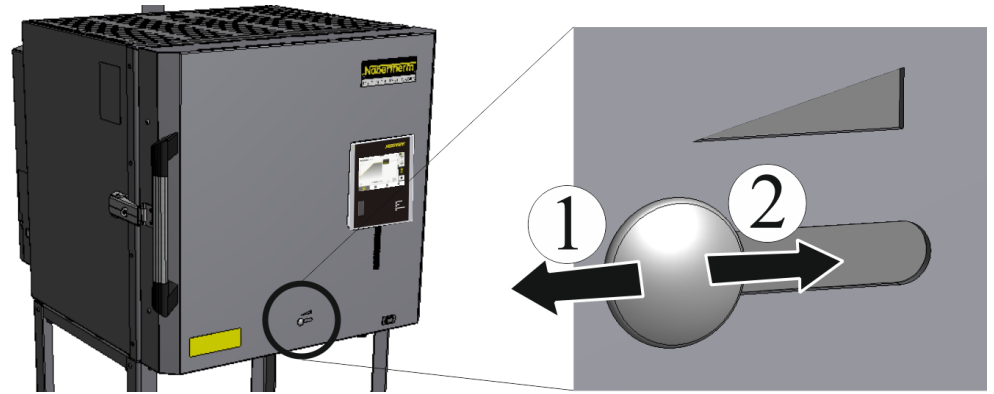
Air inlet flap

1 = close
2 = open



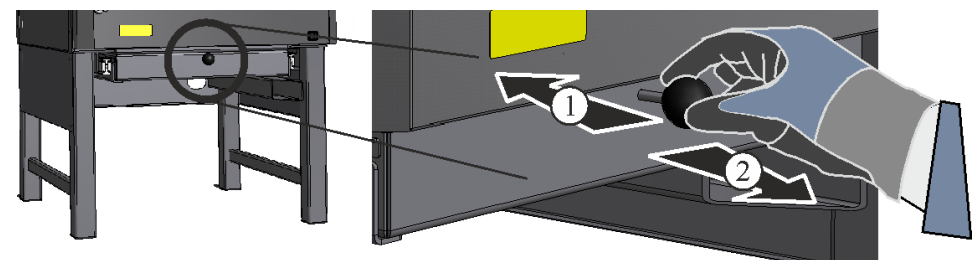
Fresh-air slide

1 = close
2 = open



Air inlet

1 = close
2 = open



Air inlet

1 = close
2 = open

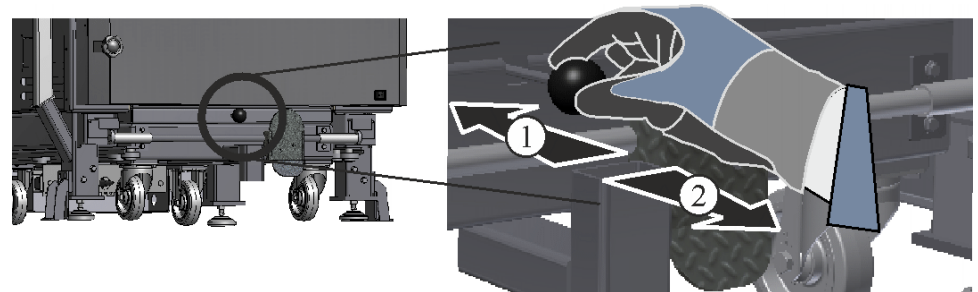


Fig. 86: Regulate the fresh air feed using the air inlet valve or flap (model-related) (similar to picture)

7.9 Schematic Description of Fresh Air Supply

When ceramics are being fired, gases, vapors, and moisture occur that may cause corrosion on the furnace. To ensure optimum removal of the exhaust gases to the atmosphere, ideally the inlet air opening and exhaust air flap (if present) should remain open to 650 °C (1202 °F) and then be closed to achieve good temperature distribution.

Our chamber furnaces are not suitable for use as drying cabinets.

To reduce the cooling phase after a firing, the inlet air opening (and the exhaust air flap if present) may be opened completely or partially.

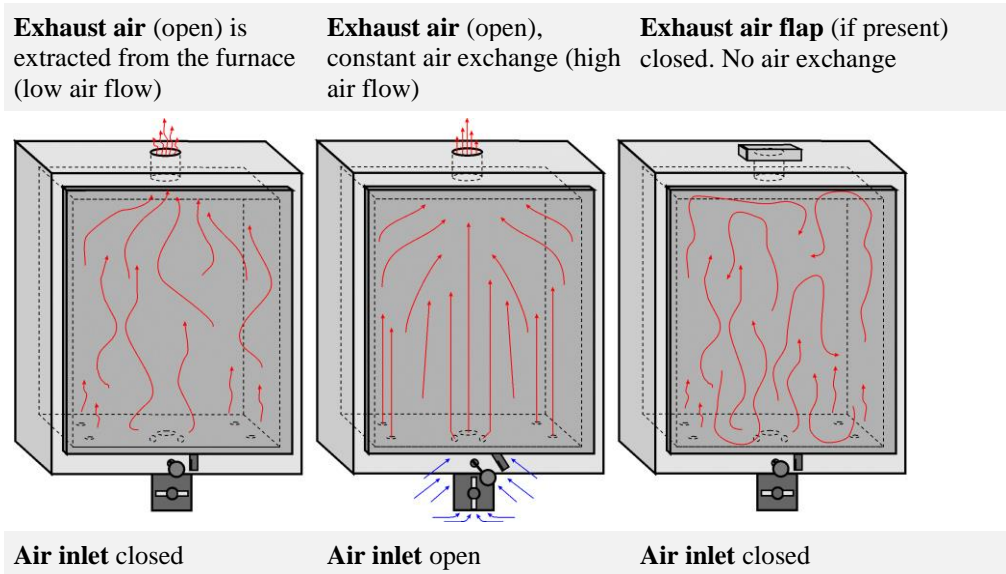


Fig. 87: Schematic description of fresh air supply

7.10 Fresh Air and/or Cooling Blower (Additional Equipment)

It is possible to accelerate cooling by switching on the cooling blower and opening the exhaust-air flaps. The rpm control and the associated air quantity can be controlled or regulated using the switchgear and control box in combination with the entered program. See the section "Operation, Display and Switch Elements".

- The switching on of the forced cooling must always be appropriate for the characteristics of the product, switching the forced cooling on at T_{max} is impermissible and endangers both the furnace and the charge
- We recommend keeping the exhaust-air flaps closed at furnace temperatures > 1000 °C (1832 °F)
- From temperatures lower than 800 °C (1472 °F) an active cooling can be used with a smaller variable
- High cooling speeds enabled by opening the exhaust-air flaps or by using the fresh-air fans at high temperatures result in increased wear and tear on the insulation and the firing auxiliaries
- A high variable of the fresh-air fans at high temperatures can lead to burns in the vicinity of the exhaust-air flap and the areas above it

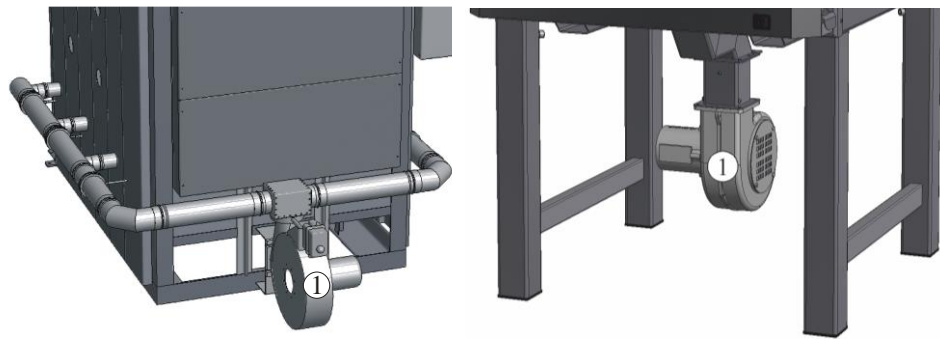


Fig. 88: Fresh air and/or cooling blower

8 Tips for Potters

Furnace loading

Note

The temperature specifications given by clay and glaze producers must be observed. They will be happy to provide you with suitable firing curves for the products.

Open the furnace door carefully.

Use only materials whose properties and melting temperatures are known. Read the relevant safety data sheets.

When charging the furnace, make sure that the door collar and the heating elements are not damaged. Avoid touching the heating elements when charging the furnace as otherwise the elements could be destroyed.

Large quantities of material in the furnace can substantially lengthen the heating-up time.

For good firing results and even temperature distribution, we recommend that the pots be distributed evenly among the individual shelves.

When the furnace is full, close the door carefully. Close the door slowly so as not to damage the insulation. Make sure that the door is closed properly.

If it can be at all avoided, do **not** open the furnace when it is hot. When it is necessary to open the furnace at a high temperature, the time should be kept to an absolute minimum. Wear the appropriate protective clothing, and ensure adequate ventilation; see "Safety".

Stainless steel sheet can discolor (especially if the furnace is opened while hot), but this does not impair the functionality of the furnace.

The volume of air fed to the furnace can be adjusted with the air inlet valve or flap (model-related). The air inlet valve/flap is located on the base of the furnace.

After the chemically bound water has been expelled from the ceramics during the firing (max. 600 °C (1112 °F)), the air inlet flap or valve (model-related) of the furnace must be closed to prevent drafts and to ensure good temperature uniformity in the upper temperature range.

Alternatively, the air inlet flaps/valves can be operated with an electric drive system that is controlled fully automatically via the controller.

By default, the models in the chamber furnace series N 140 E(L) – N 280 E(L), N 100(H)(14)(G) – N 300(H)(14)(G) and NW 150(H) – NW 300(H) have a **semi-automatic, electromagnetic controlled air inlet flap**.

With this function it is possible to dry the ceramics at low temperatures before the actual firing begins with the air inlet flap closed (good temperature distribution in the furnace).

Before the program starts, the air inlet flap must be opened manually. During the process, the air inlet flap can be closed once in a desired program segment via **extra function 1** of the controller (see separate controller instructions). **The air inlet flap must be re-opened manually before the next firing.**

When ceramics are being fired, gases, vapors, and moisture occur that may cause corrosion on the furnace. To ensure optimum removal of the exhaust gases to the atmosphere, ideally the inlet air opening and exhaust air flap (if present) should remain open to 650 °C (1202 °F) and then be closed to achieve good temperature distribution.

Our chamber furnaces are not suitable for use as drying cabinets.

To reduce the cooling phase after a firing, the inlet air opening (and the exhaust air flap if present) may be opened completely or partially.

Using the shelves and props included with the delivery

By default, furnace models **without SiC bottom tile/s** have three ceramic shelves (A) to prevent damage to the "soft" bottom of the furnace (e.g. indentations). Furnace models **with bottom heating** but **without SiC bottom tile/s** also have three props (B) to prevent heat accumulating between the bottom heating and a subsequently inserted shelf (accessory).

Nabertherm accepts no liability for damage to the bottom of the furnace or to heating elements if these shelves and props are not used. Damaged shelves and props must be replaced immediately (see "Accessories").



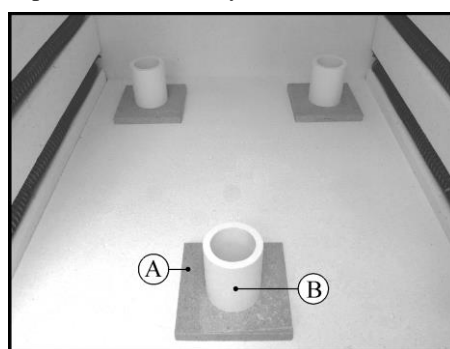
A = 691600956

Ceramic shelves supplied with furnaces without SiC bottom tile/s.



B = 691600185

Ceramic props supplied with furnaces with bottom heating but without SiC bottom tile/s.

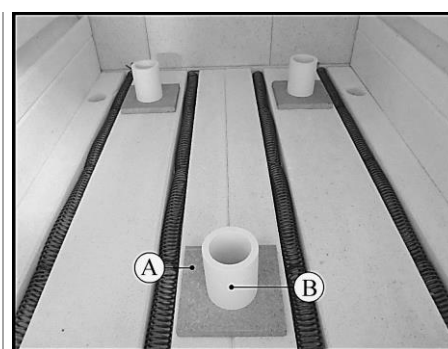


Furnace bottom **without** bottom heating (without SiC bottom tile)

Furnace model N 40 E – N 100 E

A = Ceramic shelf

B = Prop (not included in delivery - accessory)



Furnace bottom **with** bottom heating (without SiC bottom tile)

Furnace model N 140 LE – N 280 E

A = Ceramic shelf

B = Prop (included in delivery)

Fig. 89: Example: Ceramic shelves to protect the bottom of the furnace (similar to picture)

Arrangement of the Shelves and Props (Accessories)

With shelves to size 540 x 440 mm we recommend that the props be arranged in a triangular pattern to ensure stability.

First, place three props (B) in a triangular pattern on top of the ceramic shelves (A) (only furnaces without an SiC bottom plate). The ceramic shelves must have been placed evenly on the floor of the furnace beforehand. The distance between the props (B) depends on the size of the shelves and should be as large as possible to ensure stability.

Place the shelf (C) on top of the props. Now place the pots to be fired in the furnace and distribute them as evenly as possible. If a second layer is required, place props on the shelf to get the required distance between the shelves.

Notice: When inserting the shelves, make sure that the door collar and the heating elements are not damaged. Avoid touching the heating elements when inserting the shelves as otherwise the elements could be destroyed.

The bottom of the furnace is made from high-quality refractory material, however, this material is extremely sensitive to impact and pressure.

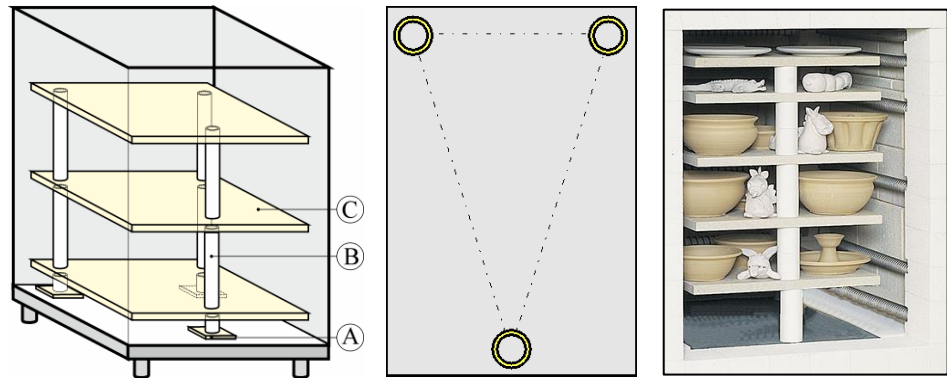


Fig. 90: Example 1: Individual shelves (similar to picture)

Vibration may occur due to movements of the drawer (NW 150 – NW 300(H)) or the bogie (NW 440 – NW 2200(H)). A four-point pattern of the props and shelves (C) ensures more stability of the complete arrangement together with the objects to be fired.

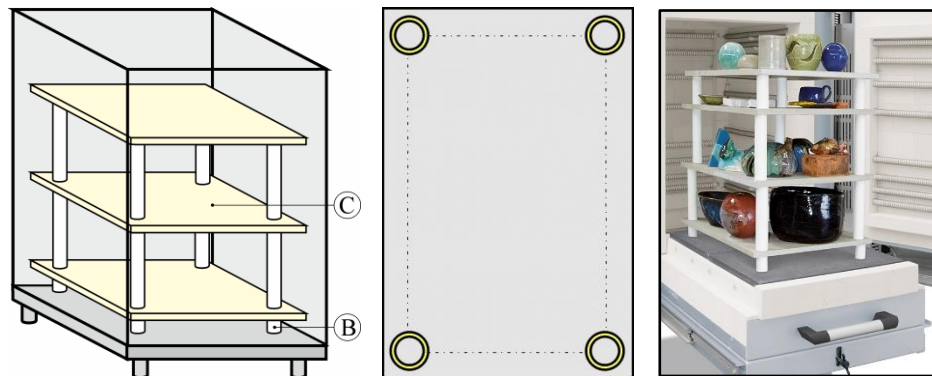


Fig. 91: Example 2: Individual shelves with furnace model NW ... (similar to picture)

In the case of furnace models with several individual shelves (C) in one level, we recommend that props (B) be arranged in a triangular pattern for each shelf to ensure stability.

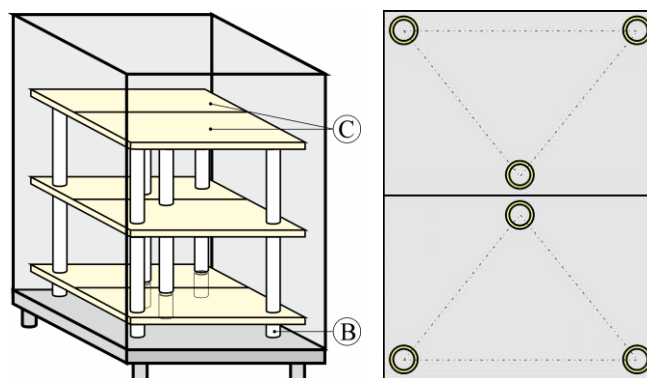


Fig. 92: Example 3: Several individual shelves on one level (similar to the picture)

Note

The temperature specifications given by clay and glaze producers must be observed. They will be happy to provide you with suitable firing curves for the products.

So that the pottery that you have made with a lot of effort and love is not destroyed, the following principles should be observed:

- Allow pottery to dry slowly – not in the kiln, a heated room or in the sun.
- Dry pottery away from drafts – drafts cause uneven drying and drying cracks.
- Loosely cover projecting parts (e.g., handles) with paper or plastic film, as they dry faster than the rest of the pot. If you don't do this, cracks may occur at the joints.
- Allow the pottery to dry for at least one week – longer in cool basements.
- Clay shrinks when it dries; in other words, the volume is reduced due to the loss of water. Objects that stick to a surface crack when they shrink – therefore, always place your pottery on fresh, clean surfaces.
- Turn your pottery often as the top dries quicker than the bottom.
- Handle dry pottery carefully with both hands and don't lift it by the edges. Pottery is very fragile in this state.

8.1 Bisque Firing

When the greenware is completely dry, it is bisque fired; that is, it is fired in the furnace at between approx. 900 °C and 950 °C. The first firing – for unglazed pottery (terracotta) the only firing – changes the physical and chemical properties of the clay. It becomes "bisque ware" (like a clay brick) and is hard and cannot be dissolved in water.

During the bisque firing the pots in the furnace can touch each other. They can be stacked (also inside each other) as long as they are not too heavy or do not prevent each other from shrinking. Tiles or flat plates should be placed directly on the shelves to prevent distortion. It really depends on the size of the objects whether they are stacked on several shelves or if a few larger pieces fill the entire furnace. But the chamber should not be "overloaded" to ensure sufficient air circulation. For the firing it is important that you know what happens to the pottery. It loses a lot of water and shrinks. If the furnace temperature is raised too quickly, the steam does not have enough time to escape and objects can crack and damage the furnace. Therefore, the furnace should be heated slowly to about 650 °C at approx. 100 °C to 150 °C per hour. Chemically bound water escapes from the clay until about this temperature. From this time you can heat the furnace to the final temperature at full power. Nabetherm controllers handle this task fully automatically.

The controller instruction manual contains all the details.

Because of the large mass and the good insulation, it takes several hours for the furnace to cool; be patient. You should open the lid a little only when the furnace has reached about **100 °C**.

When the furnace is completely open, many people are amazed to find that there have been several changes to the pottery. The pieces are smaller, they are lighter in color, the clay has a different color, the bisque ware is hard and you can now lift a pot by its handle without fear of it breaking off.

8.2 Glaze Firing

Usually, the glaze firing is the highest temperature firing. The temperature range for earthenware (usually red or brown clay) is about 1020 °C to 1100 °C. For stoneware (usually white clay) the furnace has to reach at least 1250 °C. The glazes must be adapted to suit the temperature range.

The top of the shelves should be painted with a separating agent (batt wash) before a glaze firing. This coating should be renewed from time to time.

Check the areas where the pottery is to stand - they must be free of glaze. Pottery with a glazed base must be placed on stilts or triangular rods for the firing. Glazed pottery should be handled very carefully and should not be touched at the edges. The pots must not touch in the furnace - the glaze would fuse together (there should be a few centimeters between the pots). There must also be a gap of at least 2 cm to the heating elements.

Always use only glazes in one melting range (e.g. 1050 °C) in a firing. Heat the furnace to about 500 °C at reduced power (approx. 180 °C per hour, see also controller instructions) (water escapes from the glaze), and then heat to the final temperature at full power. Hold this temperature for about 30 minutes so that the glaze melts evenly throughout the furnace.

Only open the lid or door when the temperature has dropped to **below 50 °C**. Many glaze cracks are the result of opening the lid too soon.

You can grind any glaze drops on the bottom of the pottery or the shelves with a grinding stone or an angle grinder - paying attention to all the safety regulations.

Do not use very runny glazes to avoid damaging the shelves, the furnace insulation or the heating elements and the furnace itself.

You can obtain firing and glazing accessories and specialist literature from a specialist dealer in your neighborhood. We will be happy to provide you with addresses.

8.3 Reduction Firing



In a reduction firing, oxygen in the furnace is consumed by means of a foreign substance. However, since oxygen is needed to maintain the protective oxide layer on the heating elements NO reduction firings should be carried out in an electrically heated furnace.

Under certain circumstances, high concentrations of gases can settle in the insulation and destroy it.

If it is unavoidable, after each reduction firing the furnace must be fired with a normal atmosphere to replace the protective oxide layer on the heating elements.

No warranty claims will be accepted for damage caused by reduction firings.

8.4 Preset Programs for Ceramic Applications

With Controllers B500/510, C540/550 and P570/580 the following programs are preset and can be started directly.



Note

In all cases, observe the information and references from the producers of raw materials that may require preset programs to be changed or adjusted. There is no guarantee that preset programs will produce optimum results. The programs set in the factory may be overwritten for personal purposes.

Note


The example programs for ceramic applications are stored in the factory in programs “P02 - P05”.




Notice: The programs set in the factory may be overwritten for your own purposes.

The example shows the program on P02 (BISCUIT 950)

Starting a program:

Call up the stored program from the overview by pressing the  icon.

Select the program with program number “P02”.

The program has now been loaded and can be started on the controller with the  button.

Acknowledge the subsequent security prompt by clicking “Yes”.

Program 02

Program name: Biscuit firing, slow ("BISCUIT SLOW 900")

				Manual air inlet flap ¹	Semi-automatic air inlet flap ³	Automatic air inlet flap ⁴
Segment	Start	Target	Time		Extra 1	
1	0 °C	600 °C	480 min	Open manually	Open manually (0)	Opens automatically (1)
2	600 °C	900 °C	0 min ²	Close manually	Closes automatically (1)	Closes automatically (0)
3	900 °C	900 °C	20 min	-	0	0
4	900 °C	0 °C		-	0	0

¹ Air inlet flap us opened and closed manually

² The furnace is heated to the set temperature as quickly as possible.

³ In the case of furnaces with a semi-automatic air inlet flap, the flap is closed when the extra function (Extra 1) is activated.

⁴ In the case of furnaces with an automatic air inlet flap, the flap is opened when the extra function (Extra 1) is activated.

Program 03

Program name: Glaze firing, earthenware ("GLAZE FIRING 1050")

				Manual air inlet flap ¹	Semi-automatic air inlet flap ³	Automatic air inlet flap ⁴
Segment	Start	Target	Time		Extra 1	
1	0 °C	500 °C	180 min	Open manually	Open manually (0)	Opens automatically (1)
2	500 °C	1050 °C	0 min ²	Close manually	Closes automatically (1)	Closes automatically (0)
3	1050 °C	1050 °C	20 min	-	0	0
4	1050 °C	0 °C		-	0	0

¹ Air inlet flap us opened and closed manually

² The furnace is heated to the set temperature as quickly as possible.

³ In the case of furnaces with a semi-automatic air inlet flap, the flap is closed when the extra function (Extra 1) is activated.

⁴ In the case of furnaces with an automatic air inlet flap, the flap is opened when the extra function (Extra 1) is activated.

Program 04

Program name: Glaze firing, stoneware ("GLAZE FIRING 1150")

				Manual air inlet flap ¹	Semi-automatic air inlet flap ³	Automatic air inlet flap ⁴
Segment	Start	Target	Time	Extra 1		
1	0 °C	500 °C	180 min	Open manually	Open manually (0)	Opens automatically (1)
2	500 °C	1150 °C	0 min ²	Close manually	Closes automatically (1)	Closes automatically (0)
3	1150 °C	1150 °C	20 min	-	0	0
4	1150 °C	0 °C		-	0	0

¹ Air inlet flap us opened and closed manually

² The furnace is heated to the set temperature as quickly as possible.

³ In the case of furnaces with a semi-automatic air inlet flap, the flap is closed when the extra function (Extra 1) is activated.

⁴ In the case of furnaces with an automatic air inlet flap, the flap is opened when the extra function (Extra 1) is activated.

Program 05

Program name: Glaze firing, stoneware ("GLAZE FIRING 1250")

				Manual air inlet flap ¹	Semi-automatic air inlet flap ³	Automatic air inlet flap ⁴
Segment	Start	Target	Time	Extra 1		
1	0 °C	500 °C	180 min	Open manually	Open manually (0)	Opens automatically (1)
2	500 °C	1250 °C	0 min ²	Close manually	Closes automatically (1)	Closes automatically (0)
3	1250 °C	1250 °C	20 min	-	0	0
4	1250 °C	0 °C		-	0	0

¹ Air inlet flap us opened and closed manually

² The furnace is heated to the set temperature as quickly as possible.

³ In the case of furnaces with a semi-automatic air inlet flap, the flap is closed when the extra function (Extra 1) is activated.

⁴ In the case of furnaces with an automatic air inlet flap, the flap is opened when the extra function (Extra 1) is activated.



Note

If one of the programs described above has a higher maximum temperature than that of your furnace, this program will not be preset.

In the case of furnaces with no extra function to close the air inlet flap semi-automatically, the flap can only be opened and closed manually.

9 Servicing, Cleaning, and Maintenance



Warning – Dangers During Normal Operation!

Cleaning, lubrication and maintenance work must be performed by authorized experts following the maintenance instructions and occupational safety regulations! We recommend that the maintenance and repair work be carried out by the service team of Nabertherm GmbH. The consequence of non-adherence is personal injury, death or substantial property damage!



Warning – Danger of Electric Shock!

Only qualified and authorized electricians may work on electric equipment.



During maintenance work, furnace and switchgear must be kept voltage-free to prevent accidental start-ups (padlock) and all the movable parts of the furnace must be secured (furnace with lift door: Insert safety bolts).

- Close off a generously dimensioned workspace (perimeter chains, warning signs) before carrying out any work on the furnace
- Inform personnel and put someone in charge
- Operators may only correct malfunctions which are obviously due to an operating error!
- Furnace equipped with lift door The safety bolts on the lift door track to the left and right of the lift door must be inserted before anyone enters the furnace chamber.
- The responsible employee/supervisor must be immediately informed of any faults or damage found in the furnace. Interrupt production until the damage has been rectified. Any shortcomings discovered in electrical systems/assemblies/operating equipment must be corrected without delay.
- Wait until the furnace chamber and its attachments have cooled down to room temperature
- The furnace must be visually checked for damage at regular intervals. In addition, the furnace interior must be cleaned if necessary (e.g. vacuumed) **Warning:** When cleaning, do not contact the heating elements to avoid breaking them.
- While working on the furnace, both the furnace and the workroom must be supplied with additional fresh air
- Protective equipment removed during the maintenance work must be re-installed after the work is done
- Do not make any changes or modify the furnace in anyway. This also applies to the installation and setting of safety equipment as well as for the welding of bearing components.
- Warning regarding hanging loads in the workshop (e.g. cranes). Working beneath a suspended load (e.g. raised furnace, switchgear) is prohibited.
- The functionality of safety switches as well as any including end-switches must be checked at regular intervals (DGUV V3) or corresponding national regulations of the individual country of installation.
- To ensure a perfect temperature regulation of the furnace the thermocouple must be checked for damage before each process (visual check).
- Screws of the element holders (see section "Replacing a Heating Element") may require re-tightening. The voltage to the furnace and/or switchgear must be cut off

before performing this work. Regulations (DGUV V3) or corresponding national regulations where the furnace is installed must be observed.

- In the switchgear there are one or several switch contactors. The contacts of these switch contactors are wearing parts and must therefore be regularly maintained or replaced in compliance with (DGUV V3) or corresponding national regulations where the furnace is installed.
- In the switchgear cabinet (if included) there are ventilation screens with integrated filter mats. These must be cleaned or replaced at regular intervals to ensure adequate ventilation and venting of the switchgear! During operation the switchgear cabinet door must always be firmly locked.
- Only original Nabertherm parts may be used as replacement parts. Otherwise, the declaration of conformity or installation as well as the warranty will expire.
- Nabertherm accepts no responsibility for any damage caused by the use of non-original parts



Caution – Danger of Falling

Ignoring this can lead to fatal injury. Danger of falling exists at a height less than 1.00 m above the ground or another sufficiently broad bearing surface (for example, on elevated operating positions and workplaces, working platforms, galleries, platforms, footbridges, flying bridges, ramps and stairways), openings and recesses through which people can fall (for example in floors, platforms, installation openings, hatchways and pits, non-bearing roofs).



! DANGER

- **It is not allowed to walk on the furnace roof.**
- **There is a risk of it caving in.**
- Components can break or be damaged if they are walked upon.

9.1 Furnace Insulation

The refractory bricks (insulation) are of a particularly high quality. Due to the manufacturing process small holes or cavities may occur. These are quite normal and underline the quality features of the bricks. These holes or cavities are not a reason for complaint.

Repairs to the insulation or the replacement of components in the heating chamber may only be performed by persons who are trained about possible hazards and protective measures and can apply this knowledge without supervision.

During the work on the insulation or the replacement of components in the furnace chamber, the following points must be observed:



When repairs are made or demolition work is performed, silicon dust may be released. Depending heat-treated materials contained in the furnace, further contaminants may be contained in the insulation. To exclude possible health risks, dust concentrations must be kept to a minimum during any work performed at or near the insulation. In many countries there are specific occupational safety limits. You can acquire more relevant information by investigating the relevant legal specifications in your country.

Dust concentrations should be kept as low as possible. Dust must be removed using a suction device or a vacuum cleaner with a high-performance filter (HEPA – category H).

Strong air currents such as drafts, for example, must be prevented. Pressurized air or brush must not be used for cleaning. Piles of dust must be sprinkled.

During work on the insulation a respirator mask with an FFP2 filter or an FFP3 filter must be used. The work clothing must be loose and cover the body completely. Gloves and goggles must be worn. Soiled clothing should be cleaned before it is removed with a vacuum cleaner equipped with a HEPA filter.

Contact with skin and eyes should be avoided. The impact of fibers on skin or eyes can lead to mechanical irritation which, in turn, causes reddening and itchiness. After completing the work, or after direct contact, the skin must be washed with soap and water. If there is contact with the eyes, they must be washed out carefully for several minutes. If necessary, an eye doctor should be consulted.

Smoking, eating and drinking at the workplace is prohibited.

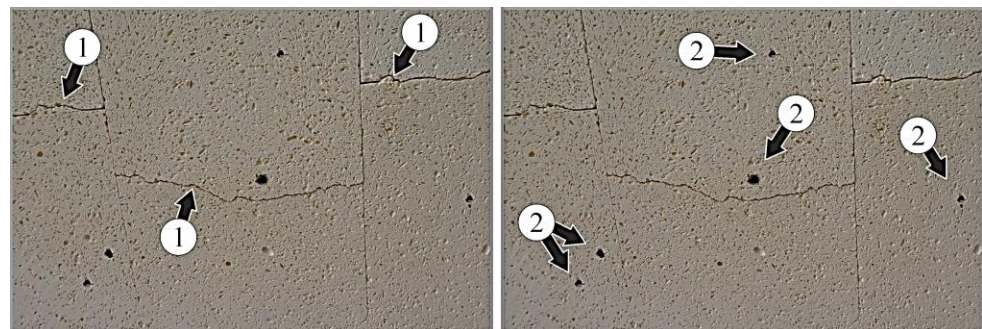
When working on insulation, the Technical Regulations for Hazardous Materials must be applied in Germany. <http://www.baua.de> (German).

Additional information regarding how to handle fibrous materials can be found at <http://www.ecfia.eu> (English).

When the materials are discarded, national and regional guidelines must be observed. The possible presence of hazardous contaminants generated by the furnace process must be taken into account.

Insulation

The furnace insulation is made from high-grade fireproof material. Due to thermal expansion, cracks in the insulation will occur after a few heating cycles. These have no influence on the function, safety or quality of the furnace. The refractory bricks (insulation) are of a particularly high quality. Due to the manufacturing process small holes or cavities may occur. These are quite normal and underline the quality features of the bricks. These holes or cavities are not a reason for complaint.



Cracks

Cavities

Fig. 93: Example: Cracks (1) and cavities (2) in the insulation after just a few heating cycles (similar to picture)

9.2 Shutting Down the Furnace for Servicing, Cleaning, and Maintenance



Warning – Dangers During Normal Operation!

Cleaning, lubrication and maintenance work must be performed by authorized experts following the maintenance instructions and occupational safety regulations! We recommend that the maintenance and repair work be carried out by the service team of Nabertherm GmbH. The consequence of non-adherence is substantial property damage, personal injury, or death!

Wait until the furnace chamber and its attachments have cooled down to room temperature.

- The furnace must be completely emptied.
- Inform operating personnel, appoint supervisory staff.
- Switch off power switch (position "O/OFF") → Switchgear
- Lock the power switch in OFF position with a padlock to prevent an accidental start-up.
- Attach a warning sign on the power switch against re-start (for example: "Danger Maintenance Work - Do not switch the furnace on")
- The protective functions of safety equipment must not be disabled.
- A generously dimensioned maintenance work area must be closed off.
- Make sure that no live voltage is present.
- Make sure the system is voltage-free (dead). The absence of voltage must be determined by an electrician or by a person with electro-technical training. The absence of voltage must be determined at the workplace on all poles.
- Ground and short-circuit the workplace.
- Cover any neighboring parts which are live.



Warning - Dangers During Normal Operation!

Do not touch any object without first having checked its temperature.



Warning – Danger of Electric Shock!

Only qualified and authorized electricians may work on electric equipment. During maintenance work, furnace and switchgear must be kept voltage-free to prevent accidental start-ups (switch off the furnace at the power switch) and secure all the movable parts of the furnace. Follow the specifications in the DGUV V3 or corresponding national regulations where the furnace is installed. Wait until the furnace chamber and its attachments have cooled down to room temperature.



9.3 Regular Maintenance Tasks for the Complete System

Warranty and liability claims for personal injury and material damage shall be excluded if regular maintenance work is not observed.

Component/ item/ function and action	Comment	A	B	C
Drives and third-party units Maintenance according to manufacturer's instructions				X2
Safety test in accordance with DGUV V3 or corresponding national regulations According to regulation				X2
EMERGENCY STOP equipment (if present) Activate the "EMERGENCY STOP", power switch, or main switch			Q	X1
Key: see "Maintenance Table Key"				



Caution – Danger of Falling

Ignoring this can lead to fatal injury. Danger of falling exists at a height less than 1.00 m above the ground or another sufficiently broad bearing surface (for example, on elevated operating positions and workplaces, working platforms, galleries, platforms, footbridges, flying bridges, ramps and stairways), openings and recesses through which people can fall (for example in floors, platforms, installation openings, hatchways and pits, non-bearing roofs).



Notice

Maintenance work must be performed only by authorized persons, observing the maintenance instructions and the accident prevention regulations. We recommend that maintenance and repair work be carried out by the service team of Nabertherm GmbH.

9.4 Regular Maintenance Tasks – Heating Elements/Furnace Chamber

Component/ item/ function and action	Comment	A	B	C
Heating elements Visual inspection: oxidation, cracks, distortion, coil unwinding, uneven distribution		3	Q	X2
Heating elements Replace		1	Y	X2
Heating element holes Clean	Recommended at the latest when replacing the heating elements	3	Y	X2
Heating element holes Replace	At the latest when replacing the heating elements	2	Y	X2
Heating element connections Wiring to the connections, corrosion tendency on twisted ends (traces of burning)		3	Y	X2

Component/ item/ function and action	Comment	A	B	C
Support tubes Visual inspection: correct position, bending, cracks		2	q	X2
Support tubes Replace	As required	2	Y	X1
Supporting bricks Visual check: correct position, cracks		3	Y	X1
Electricity, heating elements Check for even load of heating groups		-	Y	X2
Key: see "Maintenance Table Key"				


Note

Since SiC plates expand continuously, they should be replaced after about 3-5 years. Otherwise there is a risk that the collar bricks will be pushed outwards. In this case, we will not accept warranty claims.

9.5 Regular Maintenance Tasks – Heating Elements/Bogie

Component/ item/ function and action	Comment	A	B	C
Heating elements Visual inspection: oxidation, cracks, distortion, coil unwinding, uneven distribution		-	W	X2
Heating elements: Power cable clamps/wires Visual inspection: tighten		-	Y	X2
Heating elements Replace, check that electrical connections are firmly in place		1	Y	X2
Power cable clamps/wires Replace, check that electrical connections are firmly in place		1	Y	X2
Heating element connections Wiring to connection ends, corrosion tendency on twisted ends (traces of burning), check that electrical connections are firmly in place		-	Y	X2
Heating element holes Clean	At the latest when replacing the heating elements	3	Y	X2
Heating element holes Replace	Recommended at the latest when replacing the heating elements	2	Y	X2
Wiring at connection area Insulation OK		3	Y	X2
Support tubes Visual inspection: correct position, bending, cracks		-	Y	X2

Component/ item/ function and action	Comment	A	B	C
Support tubes Replace	As required	2		X2
Electricity, heating elements Check for even load of heating groups		-	Y	X2
Blade contacts Visual inspection: correct position, burning, copper compound		2	Y	X2
Key: see “Maintenance Table Key”				

9.6 Regular Maintenance Tasks – Insulation Furnace Chamber

Component/ item/ function and action	Comment	A	B	C
Door and labyrinth seal Check for damage and loose parts		-	Q	X1
Collar Visual inspection for cracks, loose segments		3	Q	X1
Fresh air inlets Check insulation for cracks		2	Q	X1
Walls Visual inspection for cracks, surface, chemical attack		3	Q	X1
Brickwork recess (inside furnace) Visual inspection for cracks		3	Q	X1
Brickwork recess (inside furnace) Vacuum		3	D	X1
Exhaust gas outlets Visual inspection of tubes for deposits		-	Q	X1
Exhaust gas outlets Replace tubes		2	Q	X2
Roof Cracks and roof suspension		3	Q	X1
Exhaust air flaps Check inserts, correct seal		3	Q	X1
Exhaust air flaps Replace		1/3	Q	X2
Exhaust air flap area Check fiber block and tube, especially the edge of the tube		3	Q	X1
Key: see “Maintenance Table Key”				

9.7 Regular Maintenance Tasks – Insulation Bogie

Component/ item/ function and action	Comment	A	B	C
Labyrinth seal Check for damage		-	Q	X1
Fiber tape seal Check that seal with furnace housing is OK		2	Q	X1
Beneath base Check for heat “spots”		3	Y	X1
SiC/mullite tile cover Check correct position and for deformation		2	Q	X1
Table Vacuum		3	M	X1
Heating chamber Vacuum		-	M	X1
Key: see “Maintenance Table Key”				

9.8 Regular Maintenance Tasks – Mechanics Bogie

Component/ item/ function and action	Comment	A	B	C
Rubber wheels Function check for easy running on the floor, visual check of rubber on the wheels		-	Y	X1
Blade contacts Visual inspection: correct position, burning, copper compound		2	Q	X2
Ball bearing, insertion aid Function check		3	Y	X1
Key: see “Maintenance Table Key”				

9.9 Regular Maintenance Tasks – Housing

Component/ item/ function and action	Comment	A	B	C
Furnace roof Visual check of cables, motors, thermocouples for thermal effects		-	Y	X2
Control thermocouples Check protective tube, position and terminal block		1	W	X1
Control thermocouples Replace		1	Y	X2
Housing surface Check for burning (exhaust air box)		3	Y	X1

Component/ item/ function and action	Comment	A	B	C
Safety switch (“door contact”) Correct switching point		2	M	X2
Safety switch, door lock Check function		2	M	X2
Housing seals Visual inspection		3	Y	X1
Blade contacts Visual inspection: correct position, burning, copper compound		2	Q	X2
Key: see “Maintenance Table Key”				

9.10 Regular Maintenance Tasks – Switchgear

Component/ item/ function and action	Comment	A	B	C
Air suction filter Replace or clean the filter mat	If this is ignored, electronic devices may break down. No liability for production losses	2	W	X1
Circuit breakers Check for burning		3	Q	X2
Circuit breakers Replace		1	Y	X2
Battery UPS Replace		1	Y	X2
Switchgear Vacuum		-	-	X2
Switchgear cabinet cooling device According to manufacturer's service manual		-	-	X2
Check function of over-temperature protection Set cutoff value to below actual value and allow to switch off		-	Q	X1
Check accuracy of over-temperature protection (calibrate) Check the adjusted cutoff temperature with a certified temperature sensor		-	Y	X2
Check temperature displays (calibrate) Check the adjusted cutoff temperature with a certified temperature sensor		-	Y	X2
Check that all screwable clamps are tight Contactors, terminals, etc., especially main switch		-	Y	X2
Check all connections for residue		-	Y	X2

Component/ item/ function and action	Comment	A	B	C
Switchgear: lamps and signals Check function		3	Q	X2
Fuses Replace after malfunction		1	-	X1
PLC assemblies with safety certification Replace according to data sheet		1	10Y	X2
Semiconductor fuses Replace after malfunction		1	-	X1
Key: see “Maintenance Table Key”				


Note

PLC assemblies with safety certification should be replaced every 10 years.


Note

If used, over-temperature limiters with automatic reset and over-temperature limiters (see “Overview of the Complete Furnace”) must be checked regularly to ensure that they function as intended. To check whether the over-temperature limiters with automatic reset and over-temperature limiters respond, start the furnace and set the required setpoint on the temperature control unit below the setpoint of the controller. For more information, see the operating instructions for over-temperature limiters with automatic reset and over-temperature limiters.


Warning – Danger of Electric Shock!

Work on the electrical equipment may be done only by qualified, authorized electricians.

9.11 Regular Maintenance Tasks – Electrical Testing

Component/ item/ function and action	Comment	A	B	C
Insulation resistance test		-	Y	X2
High-voltage test If possible		-	Y	X2
Ground wire Correct position of ground wire on the connection between the system parts and the covers		-	Y	X2
Function check All electrical components		-	Y	X2
Key: see “Maintenance Table Key”				

**Note**

The switchgear must be serviced at regular intervals by an electrician. **Contactors are wearing parts and must be checked regularly, depending on ambient conditions and frequency of use, and be replaced after no more than a year.**

**Note**

When operating furnaces with heating transformers and speed control components, the EMC filter circuit can cause an upstream residual current device to trigger. Because of this, residual current devices should not be used as protective circuits.

**Note**

The filters for the control cabinet ventilation must be cleaned at regular intervals in order to ensure good air circulation. Depending on the type and design of the ventilation system there may be 2 or 3 filters, also at other locations on the control cabinet. The door of the switchgear must be kept closed and locked (otherwise the lifetime of the electronic devices will be shortened by contamination).

**Note**




If the furnace has an interruptible power supply (UPS), you must be sure that the rechargeable battery has an operating life of roughly 2 years when operating in an ambient temperature up to +40 °C. Higher ambient temperatures or long downtimes (furnace is shut down) shorten the life of the battery. The rechargeable battery is a wearing part and, depending on the ambient conditions, must be replaced every 1 to 2 years.

9.12 Regular Maintenance Tasks – Documentation

Component/ item/ function and action	Comment	A	B	C
Type plate Legible		-	Y	X1
Operating instructions Ensure they are kept near the furnace		3	Y	X1
Component instructions Ensure they are kept near the furnace		3	Y	X1
Key: see “Maintenance Table Key”				

9.13 Maintenance Table Key

Symbols:	
A = Spare Part Stocks	1 = Stocks urgently recommended 2 = Stocks recommended / 3 = As required, not relevant
B = Maintenance Interval Notice: If ambient conditions are severe, the maintenance intervals must be shorter.	D = Daily, each time before the furnace is started W = Weekly M = Monthly / Q = Quarterly Y = Yearly /
C = Performed by	X1 = Operating personnel X2 = Specialist personnel

		
<ul style="list-style-type: none"> • Danger of electric shock. • Risk of fatal injury. • Work on the electrical equipment may be performed only by qualified electricians or by technicians authorized by Nabertherm • Switch off the furnace 		

9.14 Cleaning Products



Observe the procedure for shutting down the furnace (see “Operation”). Then remove the power plug from the socket. Allow the furnace to cool naturally.

Use commercial cleaning products that are either water-based or non-flammable and free of any solvents to clean the housing of any deposits; use a vacuum cleaner for the interior.

Pay attention to the labeling and information on the cleaning product packaging.

Wipe the surface with a damp, lint-free cloth. You may also use the following cleaning products:

This List must be Completed by the Operator.	
Component and Position	Cleaning Product
Outer surfaces (frames)*	Use commercial cleaning products that are either water-based or non-flammable and free of any solvent*
Outer surface (stainless steel)	Stainless steel cleaner
Inside	Carefully clean with a vacuum cleaner (avoid the heating elements)
Insulation materials	Carefully clean with a vacuum cleaner (avoid the heating elements)

This List must be Completed by the Operator.	
Component and Position	Cleaning Product
Door seal (if applicable)	Use commercial cleaning products that are either water-based or non-flammable and free of any solvent
Instrument panel	Wipe the surface with a damp, lint-free cloth. (e.g. glass cleaner)
*You must be sure that the cleaner does not damage the water-soluble, environmentally safe paint (test the product on an interior, hidden area).	

Fig. 94: Cleaning products

Clean quickly to protect the surfaces.

Remove the cleaning product completely from the surfaces by wiping them with a damp, lint-free cloth.





After cleaning, check all supply lines and connections for leaks, loose connections, abrasion and damage; report any defects immediately!

See “Environmental Protection Regulations”.



Note

The furnace, the furnace chamber and attached components must **NOT** be cleaned with a high-pressure cleaner.

 	 DANGER	
	<ul style="list-style-type: none"> • Danger from electrocution • Mortal danger • Switch the power switch to off before cleaning the system. • Do NOT pour water or cleaning agent on inner or outer surfaces • Dry the device completely before restarting. 	

10 Malfunctions

Work on the electrical system may be done only by qualified, authorized electricians. Operators may only rectify malfunctions that are obviously due to operating errors.

Call your local electrician for malfunctions that you cannot localize.

If you have any questions, problems, or requirements, contact Nabertherm GmbH. By mail, phone, or e-mail -> See "Nabertherm Service".

Phone advice is free and non-binding for our customers – all you pay is the phone costs.

In case of mechanical damage, send an email containing the above information and a digital photo of the damaged part and a photo of the complete furnace to the following address:

-> see "Nabertherm Service".

If a malfunction cannot be rectified with the described solutions, contact our service hotline directly.

Have the following information at hand when you phone. This makes it easier for our customer service to answer your questions.

10.1 Error Messages of the Controller

ID+ Sub-ID	Text	Logic	Remedy
Communication error			
01-01	Bus zone	Communication connection to a control module disrupted	Check that the control module is firmly attached LEDs on the control modules red? Check the cable between the control unit and the control module Plug of the connection cable not plugged correctly into the control unit
01-02	Bus communications module	Communication connection to the communications module (Ethernet/USB) disrupted	Check that the communications module is firmly attached Check the cable between the control unit and the communications module
Sensor error			
02-01	TC open		Check thermocouple, thermocouple terminals and cable Check contacts of the thermocouple cable in plug X1 on the control module (contacts 1+2)
02-02	TC Connection		Check the set thermocouple type Check poles of thermocouple connection
02-03	Compare point error		Control module defective
02-04	Compare point too hot		Temperature in the switchgear too high (approx. 70 °C) Control module defective
02-05	Compare point too cold		Temperature in the switchgear too low (approx. -10 °C)
02-06	Encoder separated	Error at the 4-20 mA input of the controller (<2 mA)	Check 4-20 mA sensor Check the connection cable to the sensor
02-07	Sensor element defective	PT100 or PT1000 sensor defective	Check PT sensor Check connection cable to the sensor (cable break/short circuit)
System error			
03-01	System memory		Error after firmware updates ¹⁾ Defective control unit ¹⁾
03-02	ADC error	Communication between AD converter and controller disrupted	Replace control module ¹⁾
03-03	File system defective	Communication between display and memory chip disrupted	Replace control unit

ID+ Sub-ID	Text	Logic	Remedy
03-04	System monitoring	Program execution on the control unit defective (Watchdog)	Replace control unit USB flash drive removed too soon or defective Switch controller off and on again
03-05	Zone system monitoring	Program execution on a control module defective (Watchdog)	Replace control module ¹⁾ Switch controller off and on again ¹⁾
03-06	Self-test error		Contact Nabertherm Service ¹⁾
Monitoring			
04-01	No heater power	No temperature increase in the ramps when heating output \leq 100 % for 12 minutes and when the temperature setpoint is higher than the current furnace temperature	Acknowledge the error (if necessary, disconnect from the power supply) and check safety contactor, door switch, heating controls and controller. Check heating elements and heating element connections. Lower D value of the control parameters.
04-02	Excess temperature	The temperature of the control zone exceeds the max. program setpoint or the maximum furnace temperature by 50 Kelvin (from 200 °C) The equation for the switch off threshold is: Maximum program setpoint + zone offset of the master zone + charge control offset [Max] (if charge control active) + excess temperature switch-off threshold (P0268, e.g., 50 K)	Check solid state relay Check thermocouple Check controller (from V1.51 with 3 minute delay)
		A program was started at a furnace temperature higher than the maximum setpoint in the program	Do not start the program until the furnace temperature is lower. If this is not possible, insert a hold time as a start segment and then a ramp with the desired temperature (STEP=0 minutes duration for both segments) Example: 700 °C -> 700 °C, Time: 00:00 700 °C -> 300 °C, Time: 00:00 The normal program begins here From Version 1.14, the actual temperature is also considered at the start. (from V1.51 with 3 minute delay)
04-03	Power failure	The set limit for restarting the furnace was exceeded	If possible, use an uninterruptible power supply
		The furnace was switched off at the main switch during the program	Stop the program on the controller before you switch off the main switch

ID+ Sub-ID	Text	Logic	Remedy
04-04	Alarm	A configured alarm was triggered	
04-05	Auto-tune failed	The determined values are implausible	Do not carry out auto-tune at the lower temperature range of the furnace working range
	Battery weak	Time is not shown correctly. A power failure may no longer be handled properly.	Export all parameters to a USB flash drive Replace the battery (see “Specifications”)
Other malfunctions			
05-00	General malfunction	Malfunction in the control module or Ethernet module	Contact Nabertherm Service Provide the service export

Error messages can be reset by acknowledging the message. Contact Nabertherm service if an error message appears again. Recirculation motors (if included) also remain switched on in case of an error until the temperature falls below the set cut-off temperature.

10.2 Warnings of the Controller

Warnings are not displayed in the error archive. They are only displayed on the display and in the file of the parameter export. Warning do not generally lead to a program crash.

No.	Text	Logic	Remedy
00	Gradient monitoring	The limit value of the configured gradient monitoring was exceeded	For troubleshooting, refer to “Gradient Monitoring” Gradient set too low
01	No control parameters	No “P” value was entered for the PID parameters	Enter at least one “P” value in the control parameters. It must not be “0”
02	Charge thermocouple defective	No charge thermocouple was determined with the current program and activated charge control	Plug in a charge thermocouple Disable charge control in the program Check the charge thermocouple and its cable for damage
03	Cooling thermocouple defective	The cooling thermocouple is not plugged in or is defective	Plug in a cooling thermocouple Check the cooling thermocouple and its cable for damage If there is a malfunction in the cooling thermocouple during active controlled cooling, the system switches over to the thermocouple of the master zone.
04	Documentation thermocouple defective	Either no documentation thermocouple or a defective one was determined.	Plug in a documentation thermocouple Check the documentation thermocouple and its cable for damage
05	Power failure	A power failure was determined. There was no program interrupt	None
06	Alarm 1 - Band	The configured band alarm 1 was triggered	Optimize the control parameters Alarm set too narrowly

No.	Text	Logic	Remedy
07	Alarm 1 - Min	The configured min. alarm 1 was triggered	Optimize the control parameters Alarm set too narrowly
08	Alarm 1 - Max	The configured max. alarm 1 was triggered	Optimize the control parameters Alarm set too narrowly
09	Alarm 2 - Band	The configured band alarm 2 was triggered	Optimize the control parameters Alarm set too narrowly
10	Alarm 2 - Min	The configured min. alarm 2 was triggered	Optimize the control parameters Alarm set too narrowly
11	Alarm 2 - Max	The configured max. alarm 2 was triggered	Optimize the control parameters Alarm set too narrowly
12	Alarm - External	The configured alarm 1 at input 1 was triggered	Check the source of the external alarm
13	Alarm - External	The configured alarm 1 at input 2 was triggered	Check the source of the external alarm
14	Alarm - External	The configured alarm 2 at input 1 was triggered	Check the source of the external alarm
15	Alarm - External	The configured alarm 2 at input 2 was triggered	Check the source of the external alarm
16	No USB flash drive inserted		When exporting data, insert a USB flash drive in the controller
17	Import/export of data via the USB flash drive unsuccessful	The file was edited with a PC (text editor) and saved in the wrong format or the USB flash drive was not detected. You want to import data that is not in the import folder on the USB flash drive	Do not edit XML files with a text editor, only in the controller. Format the USB flash drive (format: FAT32). No quick formatting Use a different USB flash drive (to 2 TB/FAT32) When importing, all data must be in the import folder on the USB flash drive. The maximum storage capacity for USB flash drives is 2 TB/FAT32). If you experience problems with your USB flash drive, use a different USB flash drive with maximum 32 GB
	Programs are rejected during the import of programs	Temperature, time or rate are outside the limit values	Import only programs that are suitable for the furnace. The controllers differ as regards the number of programs and segments and the maximum furnace temperature.
	While programs are being imported, "Error occurred" is displayed	The complete parameter set (at least the configuration files) was not stored in the "Import" folder on the USB flash drive	If you deliberately left out files during import, ignore the message. Otherwise, check the completeness of the import files.
18	"Heating blocked"	This message is displayed if a door switch is connected to the controller and the door is open	Close the door Check the door switch

No.	Text	Logic	Remedy
19	Open door	The furnace door was opened while a program was running	Close the door while a program is running.
20	Alarm 3	General message for this alarm number	Check the cause of this alarm message
21	Alarm 4	General message for this alarm number	Check the cause of this alarm message
22	Alarm 5	General message for this alarm number	Check the cause of this alarm message
23	Alarm 6	General message for this alarm number	Check the cause of this alarm message
24	Alarm 1	General message for this alarm number	Check the cause of this alarm message
25	Alarm 2	General message for this alarm number	Check the cause of this alarm message
26	Multi-zone holdback temperature exceeded	A thermocouple that was configured for multi-zone holdback has left the temperature band downward	Check whether the thermocouple is necessary for monitoring. Check the heating elements and their activation
27	Multi-zone holdback temperature undershot	A thermocouple that was configured for multi-zone holdback has left the temperature band upward	Check whether the thermocouple is necessary for monitoring. Check the heating elements and their activation
28	Modbus connection interrupted	The connection to the superordinate system was interrupted.	Check if the Ethernet cables are damaged. Check the configuration of the communication connection

10.3 Malfunctions of the Switchgear

Error	Cause	Remedy
Controller does not light up	Controller is switched off	Switch the power switch to “I”
	No power available	Is the power cord plugged into the socket? Check the building fuses. Check the fuse of the controller (if present) and replace it if necessary.
	Check the fuse of the controller (if present) and replace it if necessary.	Switch the power switch on. If the error occurs again, contact Nabertherm Service
Controller displays error	See the separate instructions of the controller	See the separate instructions of the controller
Furnace does not heat	Door / cover is open	Close the door / cover

Error	Cause	Remedy
	The door contact switch is faulty (if present)	Check the door contact switch
	"Delayed Start" is displayed	The program is waiting for the programmed start time. Deselect delayed start above the start button.
	Error in entering the program	Check the heating program (see the separate instructions of the controller)
	Heating element defective	Have this checked by Nabertherm Service or a qualified electrician.
Very slow heating of the heating space	The fuse(s) of the connection is/are defective.	Check the fuse(s) of the connection and replace if necessary. Notify Nabertherm service if the new fuse fails again immediately.
The program does not jump to the next segment	In one TIME segment in the program input, the wait time is set to INFINITE If charge control is activated, the temperature of the charge is higher than the zone temperatures.	Do not set the wait time to INFINITE
	If charge control is activated, the temperature of the charge is higher than the zone temperatures.	The parameter [LOWER BLOCK] must be set to [NO].
The controller module can not be registered on the operating unit	Addressing error of the controller module	Perform a bus reset and re-address the controller module
The controller is not heating in the optimization	No optimization temperature has been set	The temperature to be optimized must be entered (see the separate instructions of the controller)

11 Spare Parts/Wearing Parts



Ordering spare parts:

Our Nabertherm Service team is available worldwide. Due to our high vertical range of manufacture, we deliver most spare parts from stock overnight or can produce them with short delivery times. You can order Nabertherm spare parts directly from the factory quickly and easily. Orders can be made by mail, phone, or e-mail -> see "Nabertherm Service".

Availability of spare parts and wearing parts:

Although Nabertherm has many spare parts and wearing parts in stock, we cannot guarantee the short-term availability of all of them. We recommend that certain parts be ordered in good time. If you need any assistance when selecting spare parts and wearing parts, the staff at Nabertherm will be glad to help you.

**Note**

Since SiC plates expand continuously, they should be replaced after about 3-5 years. Otherwise there is a risk that the collar bricks will be pushed outwards. In this case, we will not accept warranty claims.

**Note**

Contact our Nabertherm Service for dismantling and installing wearing/spare parts. See “Nabertherm Service”. Work on the electrical equipment may be done only by qualified, authorized electricians. This applies also to repairs that are not described here.

**Note**

Original parts and Accessories are designed especially for Nabertherm furnaces. Replace parts only with original Nabertherm parts. Otherwise the warranty will be void. Nabertherm accepts absolutely no liability for damage caused by using parts that are not original Nabertherm parts.

**Note**

Wear parts such as muffles, insert boxes, roller conveyors, charging plates or sheet metal linings are subject to increased wear depending on the respective use. In addition to the process and the type of application, the service life also depends on the frequency of use. There may be distortion of these components. A slight deformation is normal and requires no further measures. However, if larger distortions occur, rework or replacement of the component is recommended. A regular check of the functionality by the customer is recommended.

11.1 Replacing a Heating Element

**Warning – Danger of Electric Shock**

Work on the electrical equipment may be done only by qualified, authorized electricians. During work it must be ensured that the furnace and the switching equipment cannot be activated by mistake (pull out the power plug) and that all moving parts in the furnace are secured. Observe DGUV V3 or the corresponding national regulations in the country where the furnace is installed. Wait until the furnace and the connected parts have cooled to room temperature.

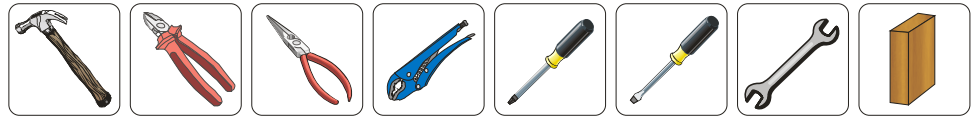
**Note**

See the enclosed circuit diagram for the wiring and electrical connections. The following installation instructions are intended only as an example. More installation steps may be required. The inlets, heating element fastening and seals differ depending on the model.

Tip: Because of the many different furnace models, we recommend that you take several photos of the initial condition, the installed heating elements and the switchgear. This will simplify subsequent installation and wiring of new heating elements.

Tools needed for assembly

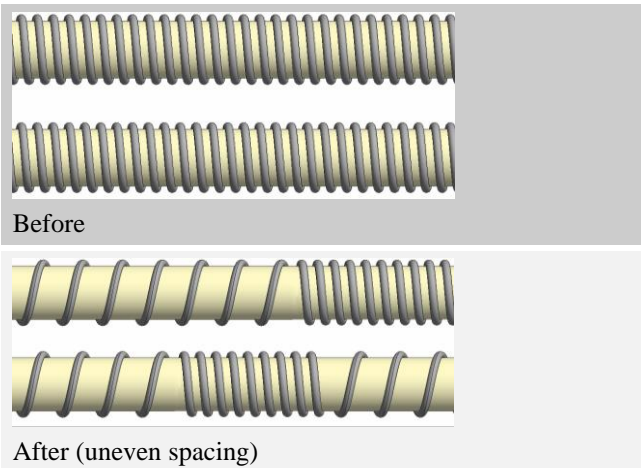
Hammer, side cutter, long-nose pliers, pipe wrench, screwdrivers (cross tip and slot), open-end wrench and a block of wood to tap in the ceramic tubes.



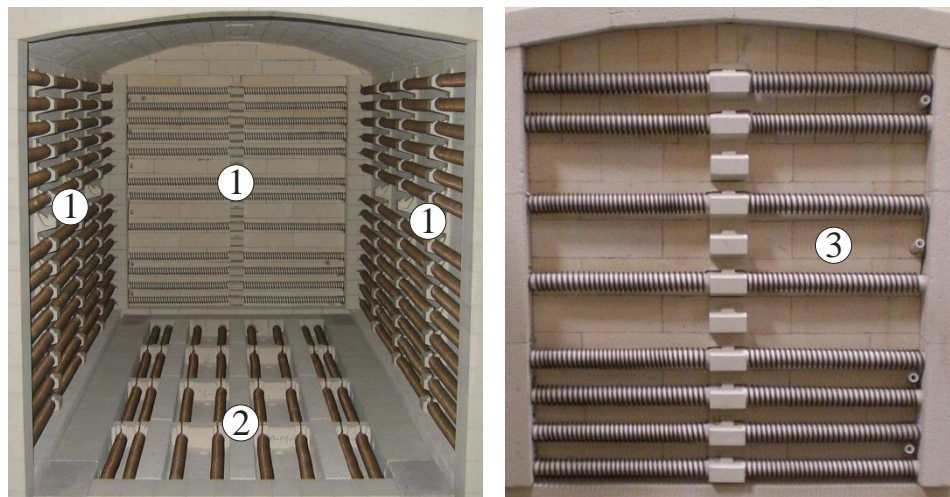
11.1.1 Heating Elements on Support Tubes

Uneven spacing

Uneven spacing is a natural process and no correction is required. However, if this is too pronounced, it may have an effect on temperature distribution.



Arrangement of the heating elements (model-related)



- 1 Heating elements, side and back walls
- 2 Heating elements, floor (remove floor tiles)
- 3 Heating elements, door

Fig. 95: Example: Heating element arrangement (similar to picture)

Position of the terminals (model-related)



Example: Heating element terminals on back wall (floor)

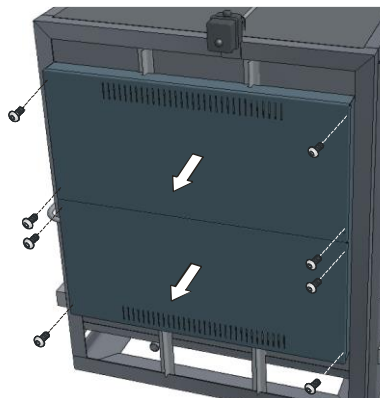
Example: Heating element terminals on door

Example: Heating element terminals on bogie

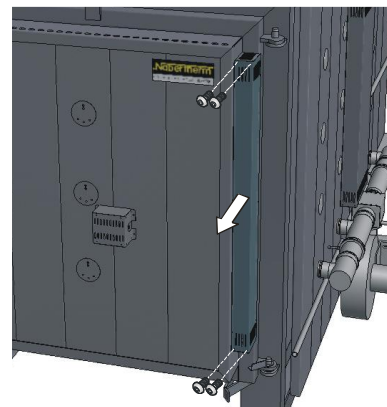
Fig. 96: Example: Connection terminals of the heating elements (similar to picture)

Removing the covers

To replace the heating elements, remove the covers on the furnace. Undo the screws of the respective cover with a suitable tool and keep them in a safe place for future use.



Example: Cover for heating element connections in the back wall



Example: Cover for heating element connections in the door

Removing the heating elements

- Remove the protective cladding from the electrical connections (lift and carefully remove the base plates from the floor).
- Undo the terminals on the ends of the heating coil. Remove the ceramic ducts and replace if necessary.
- Remove the clamps and/or ceramic tubes holding the heating elements from the brickwork (old clamps are very brittle; if a clamp breaks, remove the remainder).
- Carefully remove the heating coils with the support tubes. (Caution: older heating elements are very brittle)

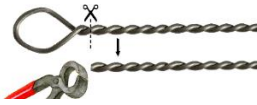
Installing the heating elements

- Check the supplied heating elements for damage before installation. With multi-zone furnaces, pay attention to the specific arrangement of the heating elements.
- Contamination in the insulation, on the support tubes, in the inlets and terminals can cause the heating elements to fail prematurely. Therefore, remove all residues from the contact surfaces of the heating elements.



Note

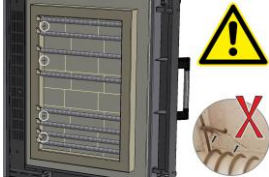
We recommend that you install new support tubes, terminals and ceramic ducts. Contaminated contact surfaces will cause premature failure of the new heating element. Replace very bent or broken support tubes.



With new heating elements, the ends (twisted) have a lug for protection. Pinch off the loops before installation.



Install the heating element together with the support tube. The bent end of the twisted wire must have contact with the insulation.



Hammer the clamps into the wall bricks at least 2 cm away from their previous position. Minor cracks in the insulation brick are normal. Do not place clamps in corner bricks, cracked areas or near the edge of the insulation bricks.

Never use the old holes for new clamps.

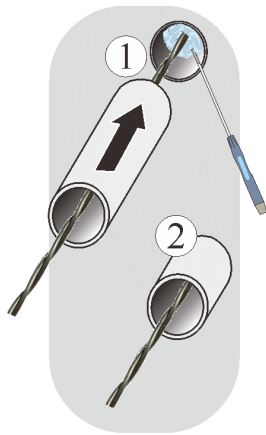


Use only new clamps.

For optimum strength, do not change the shape of the clamps.



Depending on the furnace model, ceramic tubes may be installed as holders rather than clamps.



The duct ensures electric insulation to the housing and must therefore not be damaged or contaminated. Therefore, Nabertherm recommends that you use only new tubes.

Before installing them, seal the hole with a small amount of fiber material (1). The classification temperature of the fiber material must correspond to the maximum furnace temperature.

Distribute the fiber material evenly around the end of the twisted wire with a thin blunt object (e.g., a small screwdriver).

(2) Slide the ceramic duct over the end of the twisted wire and insert it into the hole in the insulation as far as it will go. Use a hammer and block of wood to compress the fiber. Use sufficient fiber so that, in the end position, the tube compresses wadding adequately. For tubes with a collar, the collar must sit flush with the housing.

Plug the holes on the inside with fiber material in the same manner, especially if the gap between the end of the wire and the insulation has widened due to wear and tear.



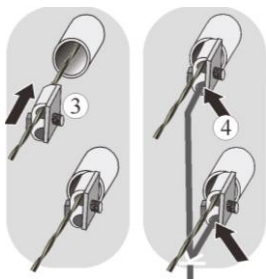
Note

Inadequate sealing can cause the terminals to overheat. Unsuitable fiber material can cause vitrification and damage.



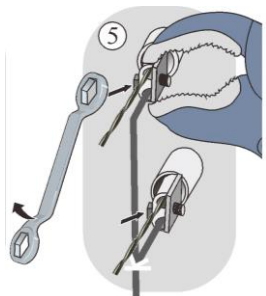
Connecting the wires: The contact surface of the wire must correspond to the length of the terminal surface.

Attach end sleeves to stranded wire cables.



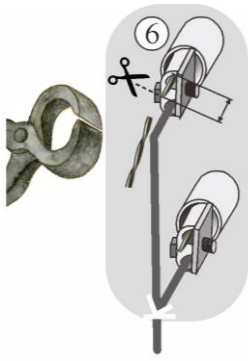
Establish the electrical connections with the connection terminals (3, 4).

The terminals must not have any traces of oxidation at the contact surfaces. Nabertherm recommends that you use only new terminals.



(5) Hold the bottom part with a pipe wrench, tighten the screw(s) with the following torque:

Terminal cross-section (mm ²)	Thread	Torque
2.5 – 16	M5	6 Nm
6 – 25	M6	8 Nm
10 – 50	M7	14 Nm



(6) If necessary, shorten protruding wires to slightly more than the width of a terminal.

Ensure that electrical connections and ground wire are connected properly.

Install the protective cladding, remembering the ground wire connection. Make sure that no cables show or are jammed.

Replace the floor tiles. If a tile is damaged or very contaminated, replace it.

Insert the plug (if present) (see “Connecting the Furnace to the Power Supply”), then switch on the power and check the furnace functions (see “Operation”).



Note

Check all screws on the connection terminals of the heating elements after one week of operation and then once each year.

Avoid all stress or twisting of the heating element.

A bad terminal contact can damage the heating element and wiring.



Note

An oxide coating must form for the heating elements to function properly.

Carry out this procedure when using the furnace for the first time and repeat **every time** a heating element is replaced.

For the duration of the oxidation firing, please refer to “Recommendations for Heating the Furnace for the First Time”.

11.1.2 Heating Elements in Grooves

For heating elements in grooves, refer to “Heating Elements on Support Tubes”. Variances must be taken into account due to the different ways the heating elements are fastened.

Insert the supplied fasteners into the wall brickwork. They are needed to prevent the heating elements lifting out of the groove when they get hot.

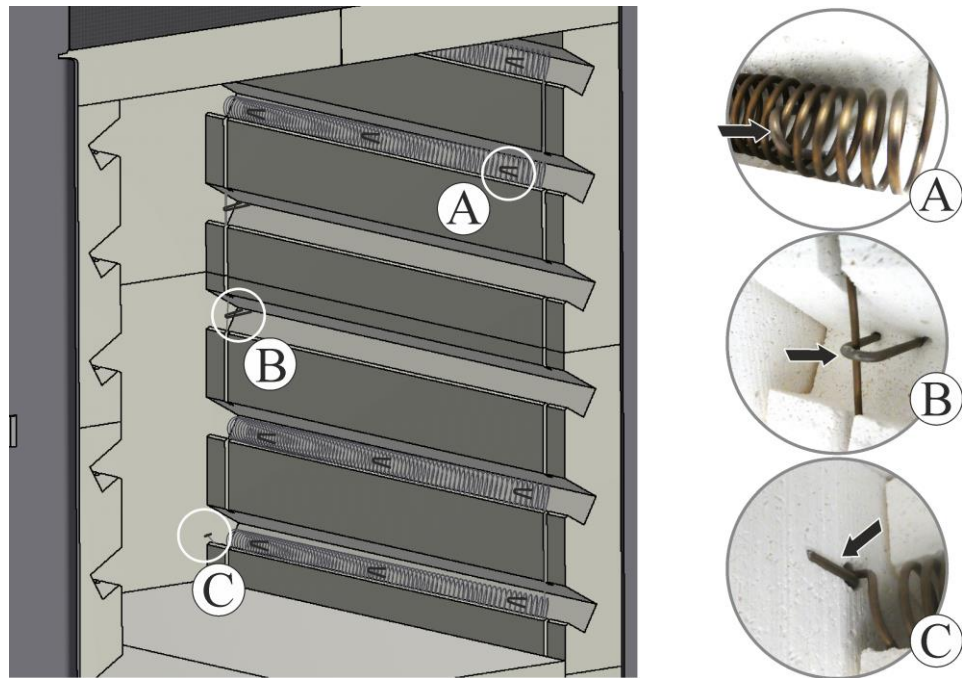


Fig. 97: Place heating wire into the groove(s) and fix with fastener(s) (similar to picture)

Do not insert the clamps into the holes of the previous clamps. We recommend moving the new clamps approx. 2 cm.

Position the fasteners in the straight wall (3) of the groove to ensure that the heating element sits properly and functions as intended. After assembly, check that heating element and fastener are positioned correctly.



X = ~14 mm

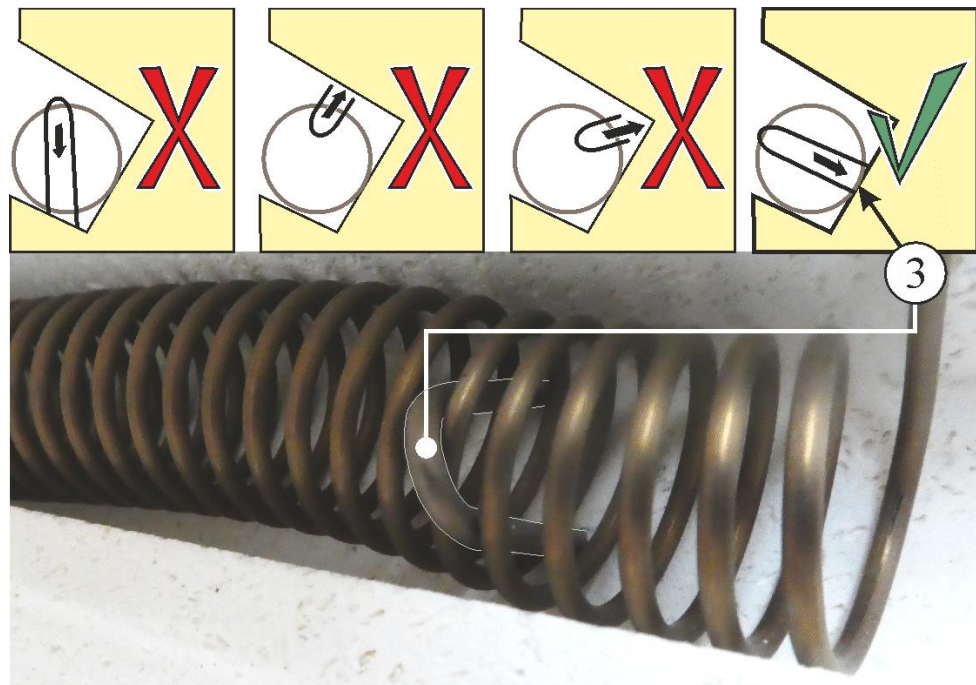


Fig. 98: Correct positioning of the fasteners (similar to picture)

Use a suitable tool to tap the supplied fasteners carefully into the insulating brick until the heating element sits completely on the brickwork. Make sure that the insulation brick is not damaged.

See other procedures in "Heating Elements on Support Tubes".

11.2 Replacing a Thermocouple



Warning – Danger of Electric Shock

Work on the electrical equipment may be done only by qualified, authorized electricians. During work it must be ensured that the furnace and the switching equipment cannot be activated by mistake (pull out the power plug) and that all moving parts in the furnace are secured. Observe DGUV V3 or the corresponding national regulations in the country where the furnace is installed. Wait until the furnace and the connected parts have cooled to room temperature.

First remove the two screws (A) from the thermocouple connection. Remove screw (B) and pull out the thermocouple (C).

Insert the new thermocouple carefully into the thermal channel (C), install and connect in reverse order. Make sure that the polarity of the electrical connections (D) is correct*).

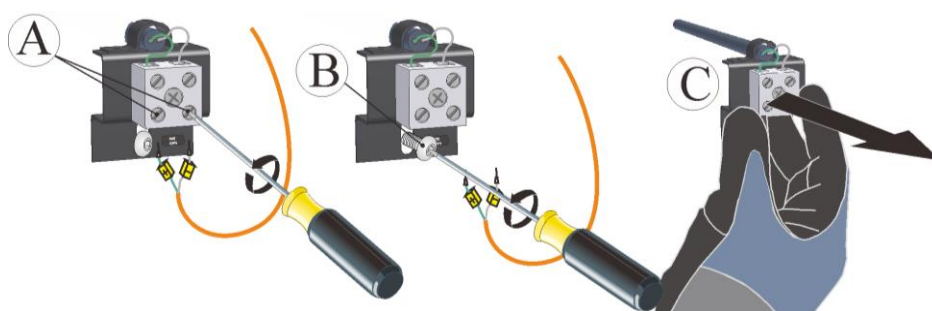


Fig. 99: Removing the thermocouple(s) (similar to picture)

Note

*) The connections of the connecting lines from the thermocouple to the controller are labeled with \oplus and \ominus . It is absolutely essential to observe the correct polarity.

\oplus to \oplus \ominus to \ominus

Commissioning

Insert the mains power connector (see chapter "Connection to the Mains Electricity"), then switch on the power switch and check the function of the furnace (see chapter "Operation").

11.3 Electrical Schematics/Pneumatic Schematics

Note

The documents included do not always contain the electrical schematics and pneumatic diagrams.

If you need the respective diagrams, they can be ordered from Nabertherm Service.

12 Accessories (Options)

12.1 Assembling the Base for Furnace Model N 40 E(R) – N 100 E (Accessory)

Remove the base from the packaging and compare the parts with the list below.






No.	Quantity	Name
A	4	
B	2	
C	2	
D	1	
E	20	

Fig. 100: Parts of the base

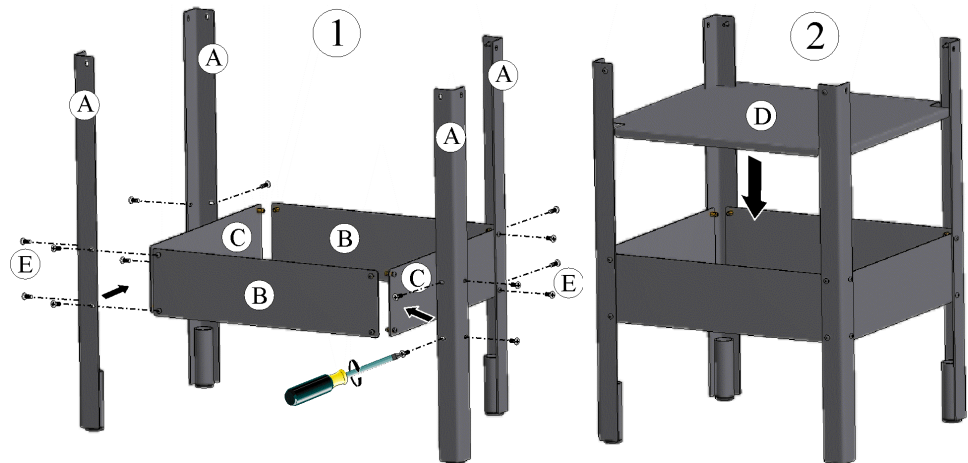


Fig. 101: Assembling the base

Assemble the individual parts (1 and 2) of the base as shown above. When the individual parts have been assembled, tighten the bolts.

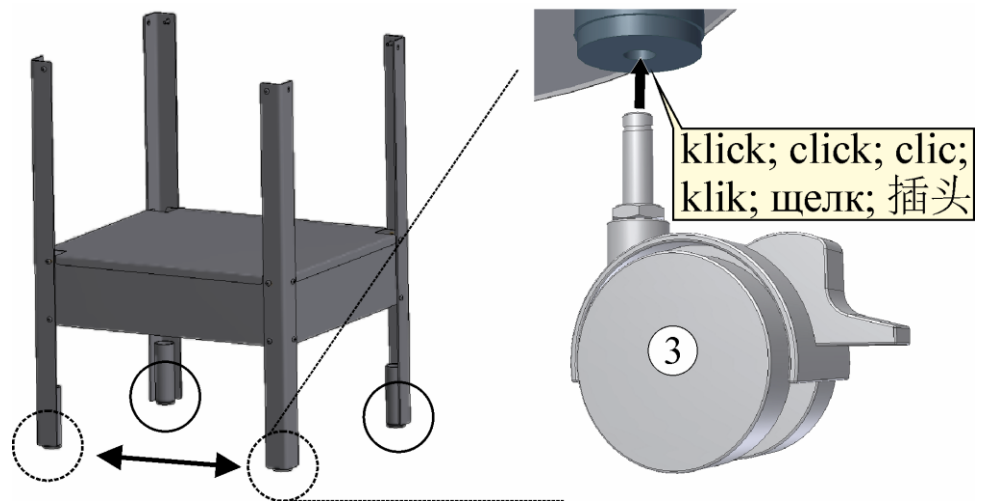


Fig. 102: Assembling the castors (if applicable)

Install the transport casters (3) (if present) beneath the feet of the base.

Assembly recommendation

Compliance with our recommendations does not release users of our products from their personal responsibility in relation to local situations and conditions. However, several general recommendations should be considered:

- Because of the weight of the furnace, we recommend that it be moved by several people while one person is responsible for assembling the base. Hold the furnace until it is firmly bolted to the base. For assistance in installing the furnace, contact Nabertherm GmbH. By mail, phone, or e-mail -> See "Nabertherm Service".
- If the base has a locking brake (4), secure the transport casters on the base (casters with brake facing the furnace door).
- Carefully and slowly place the furnace on the base (5). Make sure that it sits properly on the base.
- Connect the bolts (E) that were delivered to the base and to the threaded holes in the furnace (6). Check that all bolted connections on the bases sit properly.

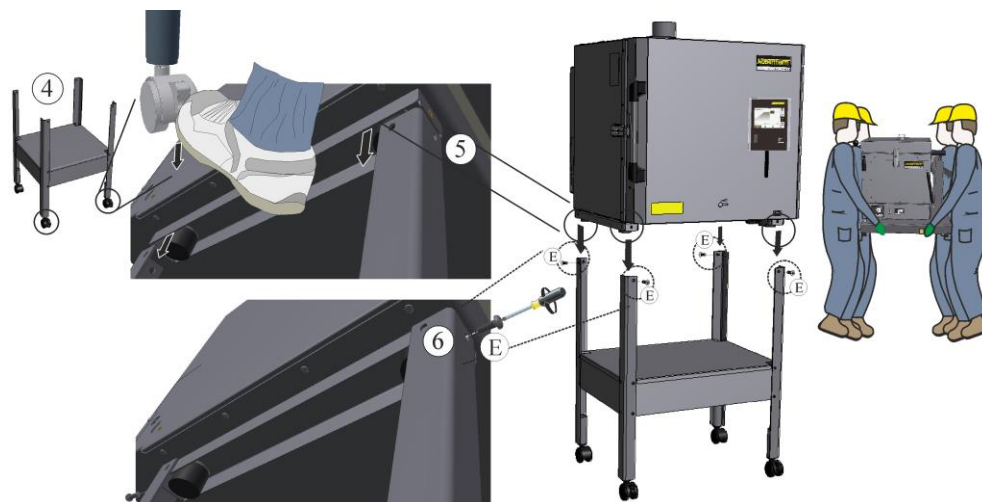


Fig. 103: Screw furnace to base (accessory)

Caution

Nabertherm assumes no liability for damages caused by improper installation.

12.2 Assembling the charging frame (accessory)

The stacked frame is moved into the furnace with a pallet truck (option) and lowered carefully. Suitable for trucks with fork widths to a maximum of 520 mm.

No.	Quantity	Name
A	1	Bottom tile
O	1	Side panel, left
C	1	Side panel, right
D	1	Load-bearing fork
E	10	Bolt M8 x 16 (SW13)
T	max. pallet truck width = 520 mm	

Fig. 104: Individual parts of the charging frame

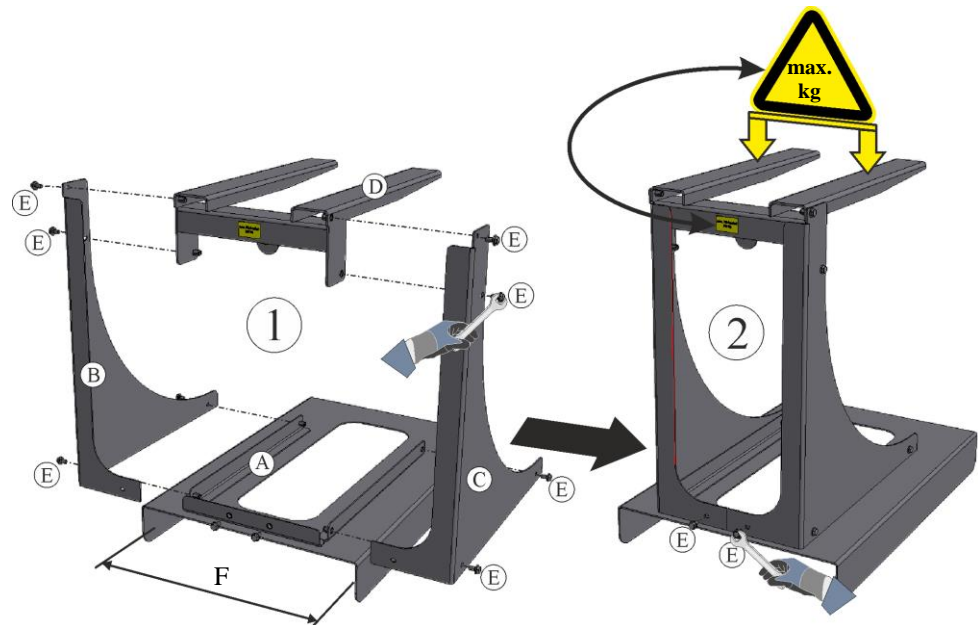
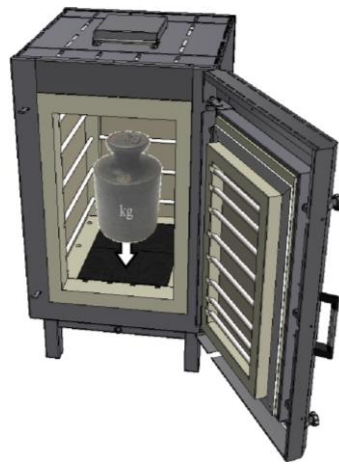


Fig. 105: Assembling the charging frame (accessory)

Place the base plate (A) on even ground. Insert the left (B) and right (C) side panels and fix them in place each with three bolts (E) (M8 x 16, SW 13). Insert the load-bearing fork (D) and fix in place with four bolts (E). Make sure that it is horizontal; it can be adjusted by means of the slotted hole for the bottom bolts.

Note

Observe the maximum distributed load of the charging frame (refer to the label on the frame).



The maximum load bearing capacity of the furnace base (filling weight) is very dependent on the temperature. We recommend approx. 50 % of the furnace volume in kg as the loading limit.

Example: N 650.. = 650 liters furnace volume (see "Specifications") corresponds to approx. 325 kg maximum load bearing capacity of the furnace base

Fig. 106: Recommendation: Maximum load bearing capacity of the furnace base



Caution

Nabertherm assumes no liability for damages caused by improper installation.

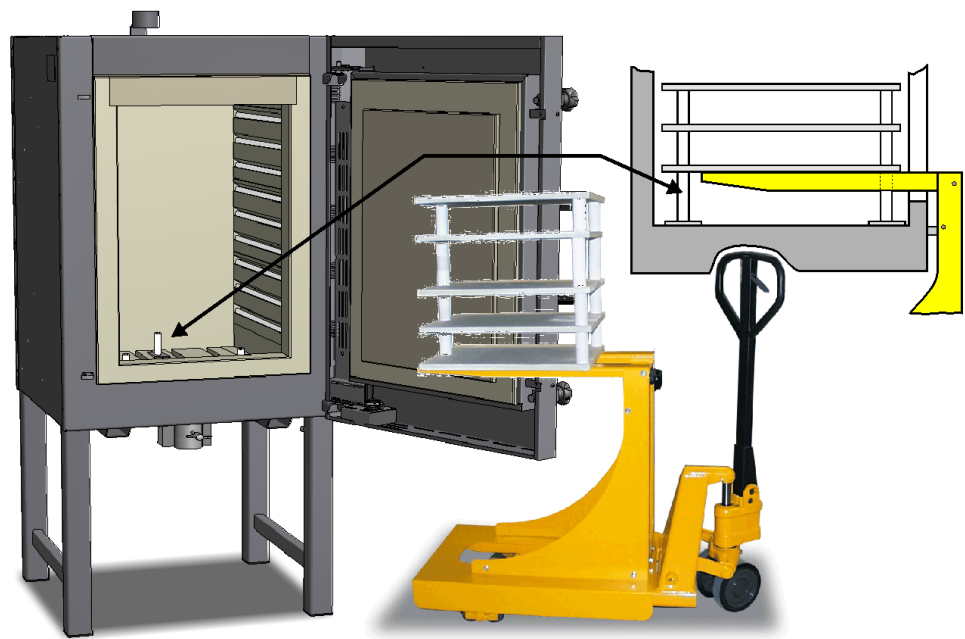




Fig. 107: Example: Charging frame with optional pallet truck

12.3 Shelves/Props

Furnace Furniture/Shelves			
Furnace model	Dimensions in mm	Part number	Figure
N 40 E	340x320x13	691 600 835	
N 70 E	340x370x13	691 600 181	
N 100 E	390x400x15	691 600 182	
N 100	490x350x17	691 600 183	
N 150	490x400x17	691 602 196	
N 150/H, NW 150	490x380x17	691 602 195	

Furnace Furniture/Shelves			
Furnace model	Dimensions in mm	Part number	Figure
N 200	490x420x17	691 602 197	
N 200/H, NW 200	490x450x17	691 602 198	
N 300	500x320x18	691 600 966	
N 140 E, N 500 E, N 440; NW 440	550x360x18	691 600 836	
N 210 E	550x410x18	691 600 837	
N 280 E	550x440x18	691 600 838	
N 660, NW 660	550x500x18	691 602 199	
Ceramic shelves supplied with furnaces without SiC bottom tile.	80x80x10	691 600 956	

Blanks may be cut from shelves

Furnace Furniture/Props			
	Dimensions in mm	Part number	Figure
Prop	Ø 50x40	691 600 185	
Prop	Ø 100x40	691 600 951	



Note

New kiln furniture (e.g. shelves and props) should be heated once to dry them out (as described above). When cold, heating elements are extremely brittle. Take great care when filling, emptying and cleaning the furnace.

The door must be locked during firing. To extract emitted gases and vapors more quickly and to shorten the cooling phase after firing, the air inlet valve or flap (model-related) can be completely or partially opened.

13 Additional Equipment

13.1 Operation with Heat Treatment Accessories

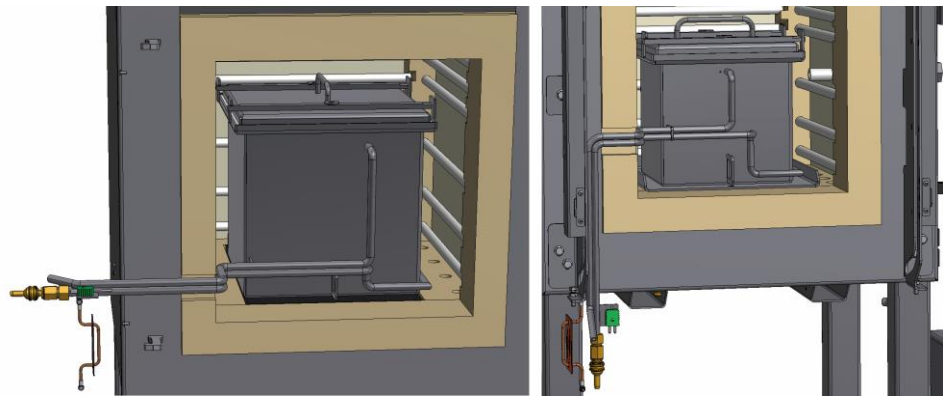
For heat treatments in protective gas Nabertherm offers protective-gas boxes and an extensive range of accessories for use in the furnaces. The advantage of protective-gas boxes is that they achieve a better protective gas atmosphere than furnaces that feed gas directly into the furnace chamber. In furnace models whose door opens downwards the penetration for the gas line is located in the upper part of the door collar, in larger furnaces whose door opens upwards, the gas line is located in the lower door collar. The protective-gas box is supplied through the protective gas inlet coupling with protective gas that, then, is released through the protective gas outlet.

The box is connected to a gassing unit and can be heated while filled with protective gas. After the heat treatment is completed, the protective-gas box is pulled out and the workpieces can then be quenched in a fluid medium or in air or be left in the furnace with the lid closed until they have cooled.



Note

Connections, operation and safety recommendations for **protective gas and carburizing systems** see separate operating manual **M04.0001**



Example: Gas inlet with a swing door

Example: Gas inlet with a lift door

Fig. 108: Example: Protective gas box (similar to picture)

When charging the annealing box pay attention to the recess of the furnace collar and the protective gas pipes.

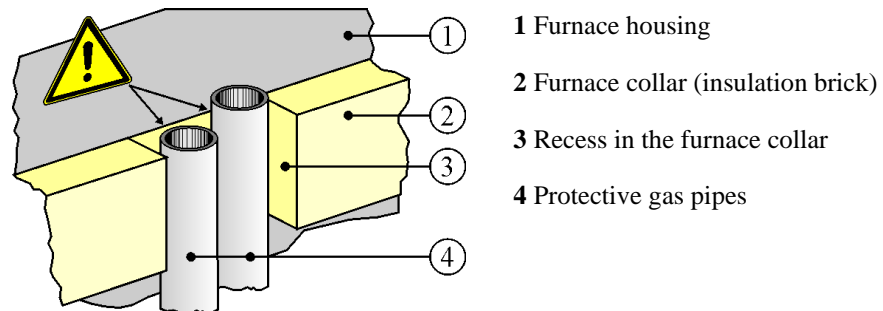


Fig. 109: Pay attention to the furnace collar and the protective gas pipes (similar to picture)



Note

If the protective gas boxes are used, a working temperature to 1100 °C (2012 °F) is recommended; with working temperatures to 1150 °C (2102 °F) the boxes will suffer increased wear.



Warning – Danger of Suffocation

There is a danger of suffocation when process/purge or exhaust gases escape, e.g. as a result of leaks (e.g. at doors, pipes, valves, etc.).

Due to their specific weight gases can displace oxygen. This poses a danger of suffocation.

Measures: Switch on the extraction system.



Note

When working with protective gases always make sure that the room is adequately ventilated. Country-specific safety regulations must also be observed.


14 Nabertherm Service

The Nabertherm Service team is available at all times for furnace maintenance and repair. If you have any questions, problems, or requirements, contact Nabertherm GmbH. By mail, phone, or the Internet.

Mail	Phone or fax	Web or e-mail
Nabertherm GmbH Bahnhofstrasse 20 28865 Lilienthal Germany	Phone: +49 (4298) 922-333 Fax: +49 (4298) 922-129	www.nabertherm.com contact@nabertherm.de

When you contact us, please have the type plate details of the furnace or controller at hand.

Provide the following details from the type plate:

 <small>MORE THAN HEAT 30-3000 °C</small>		
<small>Nabertherm GmbH Bahnhofstr. 20, 28865 Lilienthal/Bremen, Germany Tel +49 (04298) 922-0, Fax +49 (04298) 922-129 contact@nabertherm.de www.nabertherm.com Made in Germany</small>		
①	②	④
③		④
		④
		④

- ① Furnace model
- ② Serial number
- ③ Article number
- ④ Year of construction

Fig. 110: Example (type plate)

15 Declaration of Conformity



EU Declaration of Conformity

Electrically Heated Chamber Furnaces

Model	N 40 E(E/R)	N 70 E(LE)(E/R)	N 100 E(L/E)	N 140 E(LE)	N 210 E(LE)
	N 280 E(LE)	N 500 E			
	N 100(H)(14)(G)	N 150(H)(14)(G)	N 200(H)(14)(G)(GS)	N 250(GS)(S)	N 300(H)(14)(G)
	N 360(GS)(S)	N 440(H)(14)(G)	N 500(GS)(S)	N 660(H)(14)(G)	N 1000(H)(14)(G)
	N1500(H)(14)(G)	N 2200(H)(14)(G)			
	NW 150(H)	NW 200(H)	NW 300(H)	NW 440(H)	NW 660(H)
	NW 1000(H)	NW 1500(H)	NW 2200(H)		

Name and address of the manufacturer

Nabertherm GmbH
Bahnhofstr. 20
28865 Lilienthal, Germany

The above product fulfills the following harmonization regulations of the EU:

- 2006/42/EC (Machinery Directive)
- 2014/30/EU (EMC):
- 2011/65/EU (RoHS)

The following harmonized standards were applied:

- DIN EN 60335-1 (08.2020)
- DIN EN IEC 61000-6-1 (11.2019), DIN EN IEC 61000-6-3 (06.2022)

The manufacturer has sole responsibility for issuing this declaration of conformity. The signatories of the declaration are authorized to compile the relevant technical documents. The address corresponds to the specified address of the manufacturer.

Lilienthal, 13.09.2022

Dr. Henning Dahl
Vice President R & D

Gernot Fäthke
Department Manager R & D

16 For Your Notes



MORE THAN HEAT 30-3000 °C

Headquarters:

Nabertherm GmbH · Bahnhofstr. 20 · 28865 Lilienthal/Bremen, Germany · Tel +49 (4298) 922-0, Fax -129 · contact@nabertherm.de · www.nabertherm.com

Reg: M01.1038 ENGLISCH