

## Operating Instructions

### Controller

**B400/B410**

**C440/C450**

**P470/P480**

From model: Series 400-1 M03.0012 ENGLISCH

Original instructions

■ Made  
■ in  
■ Germany

[www.nabertherm.com](http://www.nabertherm.com)

---

### **Copyright**

© Copyright by  
Nabertherm GmbH  
Bahnhofstrasse 20  
28865 Lilienthal  
Federal Republic of Germany

Reg: M03.0012 ENGLISCH  
Rev: 2018-02

No responsibility is accepted for the correctness of this information. We reserve the right to make technical alterations.

<b>1</b>	<b>Introduction .....</b>	<b>6</b>
1.1	Warranty and Liability .....	7
1.2	General.....	7
1.3	Ambient Conditions .....	8
1.4	Disposal .....	8
1.5	Product Description .....	8
1.6	Defined Application.....	9
1.7	Symbols Used in this Manual .....	9
<b>2</b>	<b>Safety .....</b>	<b>10</b>
<b>3</b>	<b>Operation .....</b>	<b>10</b>
3.1	Power Switch/Control Current Switch.....	10
3.2	Turning on the Controller/Furnace .....	11
3.3	Turning off the Controller/Furnace.....	11
<b>4</b>	<b>Construction of the Controller .....</b>	<b>12</b>
4.1	Arrangement of the Individual Modules of the Controller .....	12
4.2	Control Fields .....	12
4.3	Display Fields .....	14
4.4	Display Symbols .....	15
4.5	Operating Keys .....	16
<b>5</b>	<b>Features of the Controller.....</b>	<b>17</b>
<b>6</b>	<b>Overview Pictures.....</b>	<b>18</b>
<b>7</b>	<b>Operating Instructions Summary B400/B410/C440/C450/P470/P480 .....</b>	<b>21</b>
7.1	Basic Functions.....	21
7.2	Entering a New Program (Program Table) .....	22
<b>8</b>	<b>Displaying, Entering or Changing Programs.....</b>	<b>25</b>
8.1	Displaying Programs.....	25
8.2	Entering the Programs .....	26
8.3	Preparing Programs on a PC with NTEdit .....	31
8.4	Deleting and Copying Programs .....	31
8.5	What is a Holdback? .....	32
8.6	Changing a Running Program.....	33
8.6.1	Performing Segment Jumps .....	33
8.7	Locking the Controller.....	34
8.8	Unlocking the Controller .....	35
<b>9</b>	<b>Process Documentation NTLog.....</b>	<b>35</b>
<b>10</b>	<b>Setting the Parameters .....</b>	<b>39</b>
10.1	Measurement Range Calibration.....	39
10.2	Control Parameters .....	43
10.3	Properties of the Controls .....	45
10.3.1	Smoothing.....	45
10.3.2	Heating Delay .....	48
10.3.3	Manual Zone Control.....	48
10.3.4	Integrating the actual value as setpoint for the program start .....	49
10.3.5	Controlled Cooling (option).....	50

10.3.6	Start-Up Circuit (Output Limit)	52
10.3.7	Self Optimization	53
10.3.8	Charge Control	55
10.3.9	Setpoint Offsets for Zones	58
10.4	User Administration	59
10.5	Controller Lock	62
10.5.1	Controller Lock when Program Is Running	62
10.6	Controller Lock	62
10.7	Configuring the Extra Functions	62
10.8	Deactivate or Rename Extra Functions	63
10.8.1	Manually Operating Extra Functions During a Running Heating Program	63
10.8.2	Manually Operating Extra Functions According a Heating Program	64
10.9	Alarm Functions	65
10.9.1	Alarms (1 and 2)	65
10.9.2	Acoustic Alarm	68
10.9.3	Gradient monitoring	69
10.9.4	Examples of Alarm Configuration	70
10.10	Network Failure Behavior Settings	71
10.11	System Settings	72
10.11.1	Setting Date and Time	72
10.11.2	Setting the Date and Time Formats	73
10.11.3	Language Setting	74
10.11.4	Change Temperature Unit (°C/°F)	75
10.11.5	Setting the Interface	75
10.12	Importing and Exporting Process Data, Programs and Parameters	78
10.13	Registering Modules	80
10.14	Activating an Air Recirculator	81
<b>11</b>	<b>Information Menu</b>	<b>82</b>
<b>12</b>	<b>Eurotherm 2132i Over-Temperature Limiter (Option)</b>	<b>84</b>
<b>13</b>	<b>Malfunctions</b>	<b>84</b>
13.1	Error Messages of the Controller	84
13.2	Warnings of the Controller	87
13.3	Malfunctions of the Switchgear	88
13.4	Controller Check List	89
<b>14</b>	<b>Specifications</b>	<b>91</b>
<b>15</b>	<b>Communication with the Controller</b>	<b>93</b>
15.1	Retrofitting a Communication Module	96
15.2	Scope of Delivery	96
15.3	Installing a Communications Module	96
<b>16</b>	<b>Type Plate</b>	<b>97</b>
<b>17</b>	<b>Cleaning</b>	<b>98</b>
<b>18</b>	<b>Maintenance and Spare Times</b>	<b>98</b>
18.1	Replacing a Controller	99
18.2	Removing the Controller Circuit Board	99

18.3	Installing the Controller Circuit Board .....	100
18.4	Removing the Controller Modules.....	101
18.5	Installing the Controller Module.....	101
<b>19</b>	<b>Electrical Connections.....</b>	<b>102</b>
19.1	Controller Module.....	102
19.2	Power Line Requirements.....	102
19.3	General Connection .....	103
19.4	Furnaces up to 3.6 kW – Replacement for B130, B150, B180, C280, P330 to 12.2008 .....	104
19.5	Furnaces up to 3.6 kW – Replacement for B130, B150, B180, C280, P330 from 01.2009.....	105
19.6	Furnaces, Single-Zone > 3.6 kW with Semi-Conductor Relay or Protection .....	106
19.7	Furnaces > 3.6 kW with 2 Heating Circuits .....	107
<b>20</b>	<b>Nabertherm Service.....</b>	<b>108</b>

# 1 Introduction

**Dear Customer,**

Thank you for choosing a quality product from Nabertherm GmbH.

With this system, you have selected a product which is tailored specifically to your manufacturing and production conditions and of which you can be justifiably proud.

**This product is characterized by:**

- Easy operation
- LCD display
- Rugged construction
- For use near machinery
- All Nabertherm controllers with optional ethernet interface connectable

Your Nabertherm Team



## Note

These documents are intended only for buyers of our products and may not be copied or disclosed to third parties without our written consent.

(Law governing copyright and associated protective rights, German Copyright Law from Sept. 9, 1965)

## Protective Rights

Nabertherm GmbH owns all rights to drawings, other documents and authorizations, also in case of applications for protective rights.

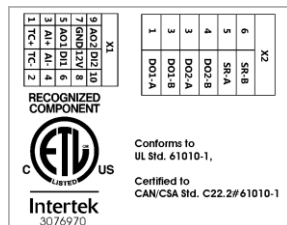

## 1.1 Warranty and Liability



**As regards warranty and liability, the normal Nabertherm warranty terms apply, unless individual terms and conditions have been agreed. However, the following conditions also apply:**

Warranty and liability claims for personal injury or damage to property shall be excluded if they are attributable to one or more of the following causes:

- All persons involved in operation, installation, maintenance, or repair of the furnace must have read and understood the operating instructions. No liability will be accepted for damage or disruption to operation resulting from non-compliance with the operating instructions.
- Not using the furnace as intended
- Improper installation, start-up, operation, or maintenance of the furnace,
- Operation of the furnace with defective safety equipment or improperly installed or non-functioning safety and protective equipment
- Not observing the information in the operating instructions with respect to transportation, storage, installation, start-up, operation, maintenance, or equipping the furnace
- Making unauthorized changes to the furnace
- Making unauthorized changes to the operating parameters
- Making unauthorized changes to the parameterization, the settings, or the program
- Nabertherm accepts absolutely no liability for damage caused by using parts that are not original Nabertherm parts. Original parts and accessories are designed especially for Nabertherm furnaces. Replace parts only with original Nabertherm parts. Otherwise the warranty will be void.
- Catastrophes due to third-party causes and force majeure
- Errors in the controller cannot be ruled out. Nabertherm does not assume any liability for the absence of errors in the controller. The responsibility for the appropriate selection and the results of using the controller as well as the intended or achieved results is born by the purchaser. No liability is accepted for any loss of data. Furthermore, absolutely no liability is assumed for any damage caused by other inadequate controller performance. Nabertherm never accepts liability for any damages from lost profits, production down-times, data loss, for damages to hardware or other damages, no matter what the type, which result from using this controller even if Nabertherm or the retailer was made aware of or informed of the possibility of said damage, as long as this is legally permissible.

## 1.2 General

Before working on electrical systems, switch the power switch to "0" and disconnect the power cord.

Even with the power switch off, some parts in the furnace may carry voltage.

Work on the electrical system may only be done by a trained person.

The furnace and switching system have been preset by Nabertherm. If required, process-specific optimization must be carried out in order to achieve the best possible control behavior.

The temperature curve must be modified by the user so that the load, furnace or surroundings are not damaged. Nabertherm GmbH assumes no guarantee for the process.



### Caution

Before working on the program-controlled grounding receptacle, the connector (optional series L, HTC, N, LH), or the connected device, always turn off the furnace and disconnect the power cord.

Read the operating instructions for the controller carefully to avoid mistakes or malfunctions in the operation of the controller or the furnace.

## 1.3 Ambient Conditions

This controller may only be operated if the following environmental conditions have been met:

- Height of the installation site: < 2000 m (sea level)
- No corrosive atmospheres
- No explosive atmospheres
- Temperature and air humidity in conformance with the technical data.

The controller may only be operated with the USB cover is in place, since otherwise dampness and dirt can enter the controller and perfect functionality cannot be ensured.

No warranty is given if the module is dirty because the USB cover was not used correctly or if there was no USB cover.

## 1.4 Disposal

These controllers contain a battery. This must be disposed of if the battery is replaced or if the controller is disposed of.

Empty batteries do not belong in the garbage. As a consumer, you are legally obliged to return used batteries. You can hand in your used batteries at your local public collection points or anywhere where batteries are sold. Of course you can also return used batteries that we provide to us.



Batteries containing toxic substances are labeled: they show a crossed-out bin and the chemical symbol of the heavy metal necessitating its classification as a source of contamination.

## 1.5 Product Description

In addition to precise temperature control, the program controller described here of the 400 series provides the option for other functions such as the control of external process devices. The operation of multi-zone furnaces, charge control and controlled cooling are examples of the extensive features of this control unit.

A further decisive characteristic is the user friendliness that is reflected in the operating philosophy, the easy-to-navigate menu configuration and the clear display design. Various menu languages can be selected for plain text information.

By default, a USB interface is integrated for process documentation and to archive programs and settings. An optional Ethernet interface is available, which enables the controller to be integrated into a local network. Extended documentation, archiving and operation is possible with the optional process documentation software, the VCD software.



## 1.6 Defined Application

The device is used exclusively to control and monitor the furnace temperature and to activate other peripheral devices.

The device may be used only under the conditions and for the purposes for which it was designed.

The controller may not be modified or converted. It must also not be used to implement safety functions. If it is used for purposes other than those for which it was intended, operating safety is not guaranteed.



### Note

The applications and processes described in these instructions are exclusively application examples. The responsibility for the selection of suitable processes and the individual application purpose is the responsibility of the operation.

Nabertherm assumes no warranty for the results of processes described in these instructions.

All the applications and processes described are based only on the experience and knowledge of Nabertherm GmbH.

## 1.7 Symbols Used in this Manual

**Explanations of how to operate the controller are supported in this instruction manual by symbols. The following symbols are used:**



Press the jog dial to select a parameter for adjustment or to confirm the set value.



Turning and pressing the jog dial. Turning changes a selected value or allows you to select a menu item. Press the jog dial to select a parameter for adjustment or to confirm the set value.



Turning the jog dial. Turning changes a selected value or allows you to select a menu item.



"START" on the jog dial. Starts or stops a heating program. Holding down the button longer stops the heating program.



The MENU operating button. Menu level selection

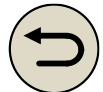

"BACK" on the jog dial. One menu level up.  
 Press and hold this button to return directly to the main overview (from V1.06)



The "INFO" jog dial. Selection of the info-menu.  
 Press and hold this button in the main overview to go directly to user logon.



Symbol for the user level that is necessary for operating (Operator, Supervisor oder Admin)

## 2 Safety

The controller has a series of electronic monitoring functions. If a malfunction occurs, the furnace automatically shuts down and an error message appears in the LC display.



### Caution

Without additional safety system, this controller is not approved for the monitoring or control of safety-relevant functions.

If the failure of furnace components presents a danger, additional qualified protective measures are necessary.



### Note

For more information, please see Chapter "Faults - fault messages"



### Note

The behavior of the controller after a grid power outage has been preset as a default setting.

If the grid power outage is shorter than approx. 2 minutes, a running program is continued, otherwise the program is aborted.

If this setting is not suitable for your process, this setting can, as a rule, be adapted to your process (see the section "Setting the Behavior after Power Outage").



### Warning! General Hazards!

The Operating Instructions must be followed prior to switching on the furnace.

## 3 Operation



### 3.1 Power Switch/Control Current Switch



The power switch/control power switch is located below or beside the controller. End the running heating programs before you turn off the furnace at the power switch.

(power switch type differs depending on features/furnace model)

### 3.2 Turning on the Controller/Furnace

Switching on the Controller		
Steps	Display	Comments
Turn on the power switch		Turn on the power switch by setting it to "I" (power switch type differs depending on features/furnace model)
The overview screen appears. After a couple of seconds, the temperature is displayed.		If the temperature is displayed at the controller, the controller is ready to operate.

All the necessary settings for perfect functions have already been made at the factory.

If necessary, heating programs can be imported by loading a program file from a USB stick.

### 3.3 Turning off the Controller/Furnace

Turn off the controller		
Steps	Display	Comments
Turn off the power switch		Turn off the power switch by setting it to "O" (power switch type differs depending on features/furnace model)



**Note**

Stop running heating programs before turning the furnace off at the main switch, since the controller will otherwise generate a fault message when it is turned back on.  
 See Faults/fault messages

## 4 Construction of the Controller

### 4.1 Arrangement of the Individual Modules of the Controller

The controller consists of the following modules:	
1	Voltage supply
2	Control modules for controlling zones and charges (-103K3/4). One control module per controller.
2a – 2c	Other modules depend on the additional features
	Communication module for USB and Ethernet connections for a PC
3	Operating and display unit (-101A8)

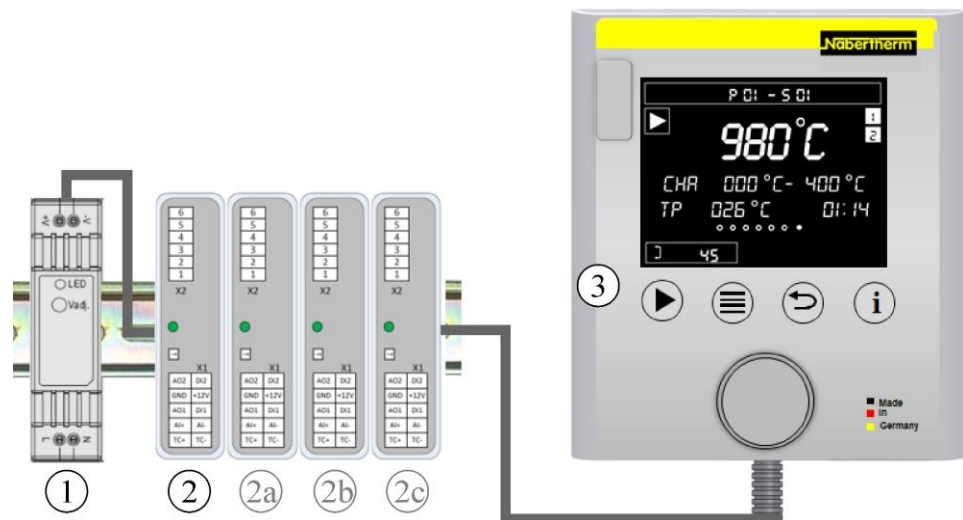

Fig. 1: Arrangement of the individual modules of the controller (similar to picture)

Voltage supply (1) and control modules (2) are located in the switchgear, the operating and display unit (3) can be installed in the front or side of the switchgear or in the front of the furnace. The control modules (2) are coupled via a pluggable connector in the back wall.

### 4.2 Control Fields

#### B410/C450/P480



Fig. 2: Control field B410/C450/P480 (similar to picture)

B410/C450/P480	
No.	Description
1	Display
2	Control keys for "Start/Hold/Stop", "Menu" selection, "Back" function and information menu selection
3	Jog dial
4	USB interface for a USB stick
5	Over-temperature limiter with manual reset (optional)

**B400/C440/P470**



Fig. 3: Control field B400/C440/P470 (similar to picture)

No.	Description
1	Display
2	Control keys for "Start/Hold/Stop", "Menu" selection, "Back" function and information menu selection
3	Jog dial
4	USB interface for a USB stick

### 4.3 Display Fields

Display area

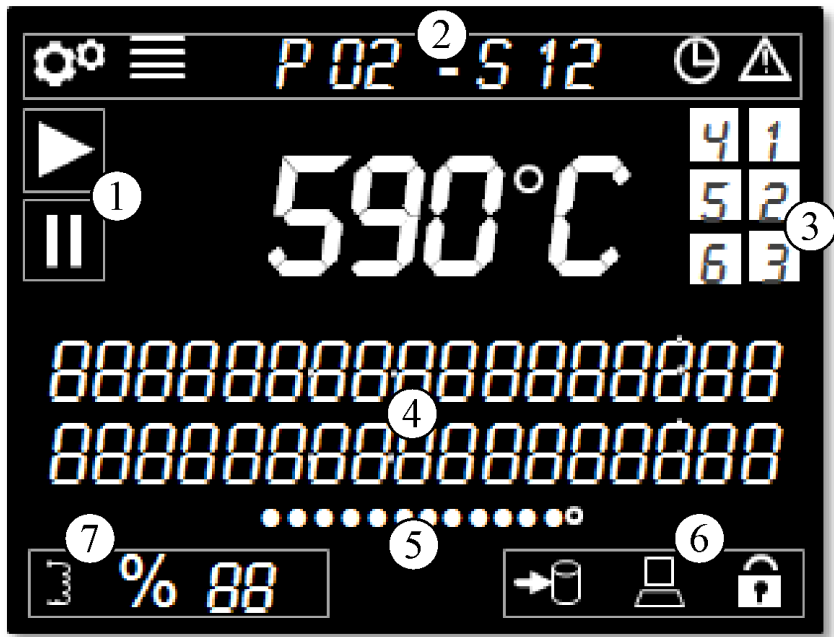

Fig. 4: Display area

No.	Function	Description
1	Program status	Operating mode of the controller. The display shows whether a heating program is running or has been held
2	Menu bar	Information about the selected menu level, a selected program and any malfunctions are displayed here
3	Extra functions	Overview of all active extra functions in the current segment. These are active in the current program as a status and also in the program entry mode.
4	Information lines	Additional information about the current function in entry mode and the current program information during the current program are displayed
5	Page display	Page display offers a quick overview of the page in the menu that you have open and also how many pages are available. If there are more than 10 menu items, more than one page can be assigned to a page display.
6	Data bar, controller lock	The data bar shows active data links, such as plugging, writing/reading (icon flashes) USB flash drives and links to VCD software. An active controller lock is also shown here.
7	Heating status	Required power output of the controller as a percentage (display [FP] at 100 %), power limit and status symbol for the heating output. If the furnace has no door switch, the heating output is displayed but is switched off.

## 4.4 Display Symbols

### Display icons

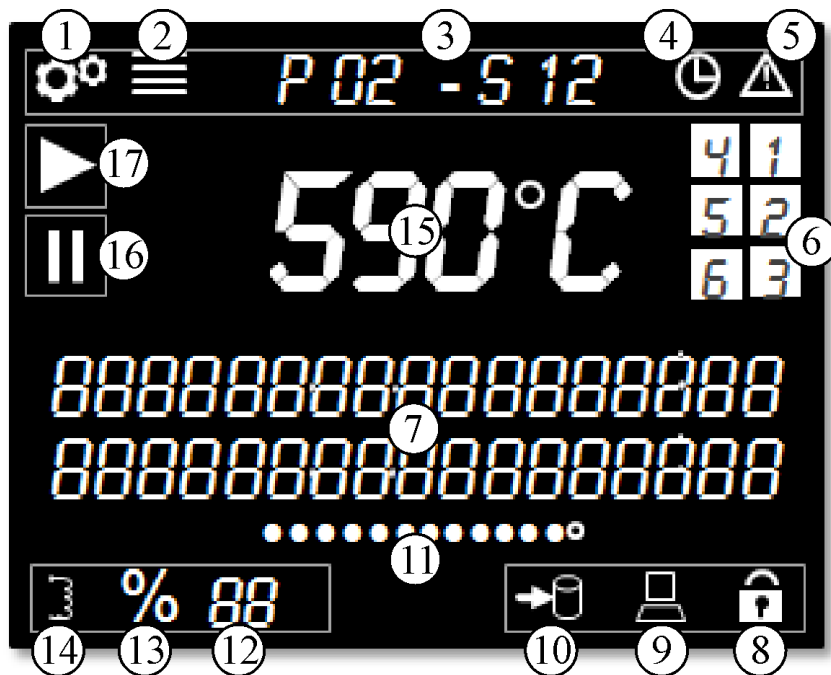

Fig. 5: Display icons

No.	Function	Description
1	Icon “configuration active”	Shows that a setting level is selected
2	Icon “menu”	If this icon is displayed, press the “menu” button to display more settings
3	Program and segment display	The current program and segment numbers are shown here
4	Icon “delayed start”	If this icon is displayed, a program is started with a delay. The icon disappears at the selected start time.
5	Icon “malfunction”	This icon indicates that there is a malfunction. The corresponding message is shown in clear text on the overview display
6	Extra functions 1-6	If a program has been started, the extra functions are displayed here
7	Information lines	Text area for explanations and entries
8	Icon “controller lock”	If this icon is shown, controller operation is locked. To unlock it, refer to “Controller Lock”.
9	PC communication	Shows active communication with VCD software
10	Icon “USB flash drive”	If a USB flash drive is plugged in, this icon is displayed. The icon flashes when data is saved or read.
11	Page display	Shows which page is selected. Turn the jog dial to navigate from one item to the next. If there are more than 10 menu items, more than one page can be assigned to a page display.

Display icons		
12	Power display in %	When a program is active, the current power of the furnace is shown here as a percentage. As regards the exact power that is displayed, please refer to “Overview Pages for Multiple Zone and Charge Controllers”. If the value reaches 100%, [FP] is displayed
13	Icon “Start-up circuit/ power limit”	This icon is displayed if start-up circuit/power limit is active
14	Icon “Heating output active”	This icon indicates an active heating output. The icon remains when the output is constant. The rate with which the icon is displayed does not correspond to the actual heating output, but relates to a cycle time of 2 seconds. When the furnace is open, this icon is still displayed but the heating is not activated
15	Furnace temperature in °C/°F	Shows the current temperature and temperature unit
16	Furnace program in hold	If this icon is displayed, the program has either been held manually or due to an alarm.
17	Furnace program started	If this icon is displayed, the furnace program was started successfully

## 4.5 Operating Keys

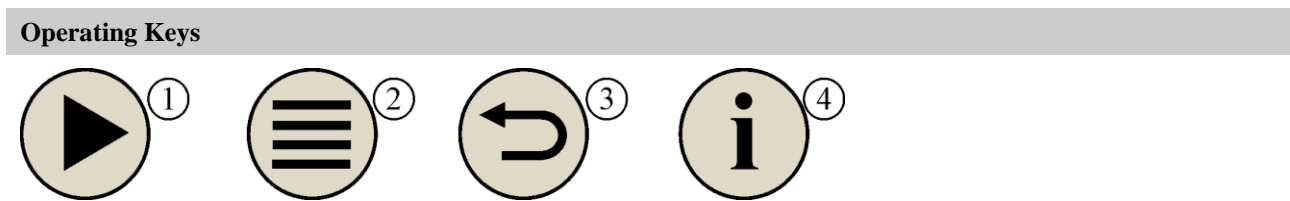

Fig. 6: Operating Keys

No.	Function	Description
1	Start/Hold/Stop	Starts or holds a heating program. Holding down the button longer stops the heating program.
2	Menu	Select the menu level
3	Back	One menu level up. Press and hold this button to go directly to the main overview (from V1.06)
4	Information	Select the information menu. Press and hold this button in the main overview to go directly to user logon.



## 5 Features of the Controller

Function		B400/ B410	C440/ C450	P470/ P480
		x = Serial feature o = Option		
	Internal over-temperature protection <sup>1)</sup>	x	x	x
<b>Program functions</b>	Programs	5	10	50
	Number of segments	4	20	40
	Segment leap	x	x	x
	Select start time	x	x	x
	Manual + automatic holdback in the program	AUTO	x	x
	Extra functions	max. 2	max. 2	max. 6
	Program name to be selected	x	x	x
	Ramps as gradient/rate or time	x	x	x
	Active extra functions also after the end of the program	x	x	x
	Copy programs	x	x	x
	Delete programs	x	x	x
	Program start at current furnace temperature	x	x	x
<b>Hardware</b>	Thermocouple type B/C/E/J/K/L/N/R/S/T	x	x	x
	Measurement input 0-10 V/4-20 mA	x	x	x
	Constant heating control	no	no	x
<b>Controller</b>	Zones	1	1	1 – 3
	Charge control	no	no	o
	Controlled cooling	no	no	o
	Manual heating circuit setting	o	o	o
	Start-up circuit	x	x	x
	Self optimization (only single zone)	x	x	x
<b>Documentation</b>	Process documentation NTLog	x	x	x
	Display and record of up to 3 additional thermocouples	no	no	o
<b>Settings</b>	Calibration (max. 10 base points)	x	x	x
	Control parameters (max. 10 base points)	x	x	x
<b>Monitoring</b>	Gradient monitoring (rate of temperature increase)	x	x	x
	Alarm functions (band/min/max)	min/max	min/max	x

Function		B400/ B410	C440/ C450	P470/ P480
		x = Serial feature o = Option		
Other	Controller lock	x	x	x
	Heating delay after door is closed	o	o	o
	User administration	x	x	x
	Changing the time format	x	x	x
	Changing between °C/°F	x	x	x
	Adjusting the power failure behavior	x	x	x
	Import/export parameters and data	x	x	x
	Protection function for air circulation <sup>2)</sup>	o	o	o
	Decimal place (< 1000 °C)	no	no	o
	Display of PID output for optimization	x	x	x
	Energy meter (kWh) <sup>3)</sup>	x	x	x
	Statistics (operating hours, consumption values)	x	x	x
	Real-time clock	x	x	x
	Acoustic signal, can be parameterized	o	o	o
	Ethernet data interface	o	o	o
	Operation with jog dial	x	x	x

1) When the program starts, the highest temperature in the program is calculated. If the furnace is 30/86 °C/°F warmer than the highest program temperature for 3 minutes during the program sequence, the controller turns off the heating and the safety relay, and a fault message appears.



2) Pre-set function for air circulation furnaces: As soon as a program was started at the controller, the air recirculation motor starts. They continue to operate until the program is ended or interrupted and the furnace temperature has again fallen below a previously set value (e.g. 80/176 °C/°F).

3) The kWh counter calculates the power theoretically consumed over the time the heater is turned on for a heating program at nominal voltage. However, there may actually be deviations: If the voltage is low, the power consumption displayed will be too high, and for a higher voltage the power consumption displayed will be too low. Aging heating elements may also cause deviations.

## 6 Overview Pictures

This controller, depending on the design, is able to control several zones. Since not all

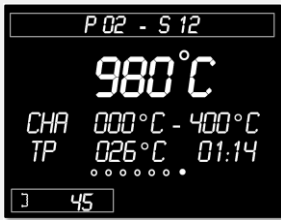
information can be displayed on one overview page, turn the jog dial  to the right to display information about the other zones. Go to the main overview. If you are not in the main overview, press the "Back" button until the settings icon on the top left disappears and you reach the main overview. You can also reach the overview page from the main overview by pressing and holding the "Back" button.

Switching between the overviews			OPERATOR
Steps	Operation	Display	Comments
Select overview			
Select zone overview		Main overview Zone overview Zones 1..3 Zone overview charge	



### Caution

The individual overviews differ in the displayed temperatures and the information in the two text lines.

### Main overview

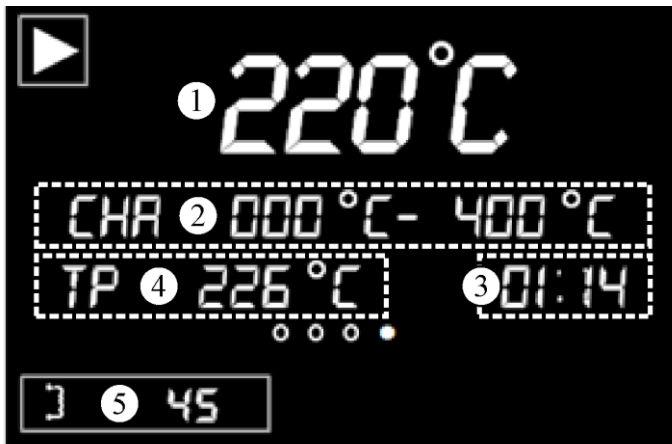

No.	Description
1	Guide temperature (master zone, cooling temperature or charge temperature with active charge control)
2	Start and target temperature of the segment ([COOL] with active controlled cooling, "CHA" is displayed when charge control is active)
3	Remaining time in segment
4	Current setpoint of the master zone or the charge control if charge control is active
5	Power of the master zone

### Zone Overview Zone 1 ..3



No.	Description
1	Guide temperature (master zone or charge for activated charge control)
2	Zone name and zone temperature
3	---
4	Current setpoint of the master zone or the charge control for activated charge control
5	Power of the selected zone

### Overview Charge Control

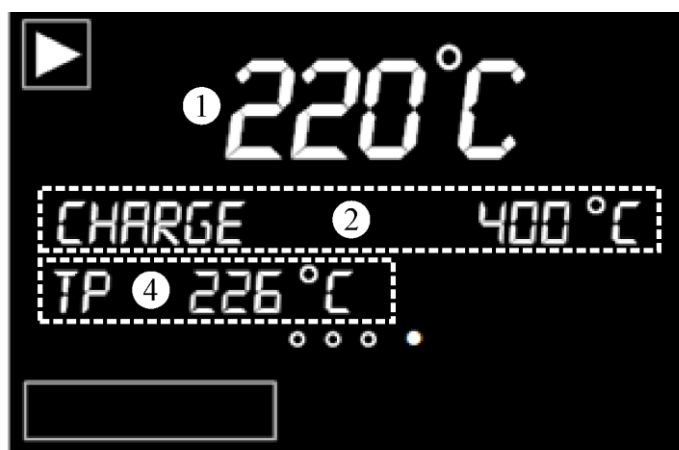

No.	Description
1	Guide temperature (master zone, cooling temperature or charge temperature with active charge control)
2	Temperature of the charge
3	---
4	Current setpoint of the charge control during active charge control
5	---

## 7 Operating Instructions Summary B400/B410/C440/C450/P470/P480

### 7.1 Basic Functions

Print this page in order to have the basic operating instructions on hand at all times.

Read the safety instructions in the controller operating instructions.

#### Read the tutorials on the Internet

To access the operating instruction quickly, scan the QR code with your smartphone or enter the Internet address in your browser:

[www.nabertherm.com/tutorials/controller](http://www.nabertherm.com/tutorials/controller)

Apps to scan QR codes can be downloaded from the corresponding sources (app stores).



#### Turn on the controller

Turn on the power switch.

You are in the overview.









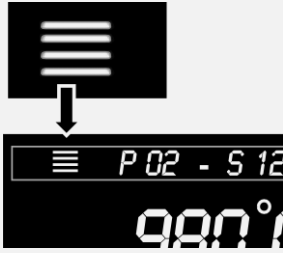

Set power switch to “I”.  
 (power switch type varies according to design/furnace model)

#### Set language with the quick selection buttons

Steps	Operation	Display	Comments
Press the Info button			
Press and hold the menu button (2 sec.)			
Briefly press the jog dial			
Turn to select the language			
Press to confirm			

#### Select overview

Steps	Operation	Display	Comments
Press the Back button			To go to the overview, press the Back button for 2 sec.

Select overview			
Steps	Operation	Display	Comments
The menu icon is shown in the top left-hand side of the display when you reach the overview.			
Load and start the program (if applicable, enter a program beforehand)			
Steps	Operation	Display	Comments
Return to overview. Briefly press the jog dial			
Turn to select the program			
Press to confirm			
Press to reject delayed start: [NO]			
Press Start to start the program			
Stop program			
Steps	Operation	Display	Comments
Press and hold the Start button to stop the current program (2 sec).			

## 7.2 Entering a New Program (Program Table)

Program entry is described in more detail in “Entering or Changing Programs”.

For simple, PC-supported program input and program import via a USB flash drive, please refer to “Preparing Programs on a PC with NTEdit”.

<b>First, fill the program table</b>	
<b>Program name</b>	
<b>Furnace</b>	
<b>Other</b>	

Program options (depending on furnace features).

<b>Activate charge control</b>	
--------------------------------	--

Segment	Temperature		Duration of the segment Time [hh:mm] or rate [°/h]	Additional functions (optional):				
	Start temperature T <sub>A</sub>	Target temperature		Controlled cooling	Extra functions			
					1	2	3	4
1	(0 °)			<input type="checkbox"/>	<input type="checkbox"/>	<input type="checkbox"/>	<input type="checkbox"/>	<input type="checkbox"/>
2	<sup>1)</sup>			<input type="checkbox"/>	<input type="checkbox"/>	<input type="checkbox"/>	<input type="checkbox"/>	<input type="checkbox"/>
3	<sup>1)</sup>			<input type="checkbox"/>	<input type="checkbox"/>	<input type="checkbox"/>	<input type="checkbox"/>	<input type="checkbox"/>
4	<sup>1)</sup>			<input type="checkbox"/>	<input type="checkbox"/>	<input type="checkbox"/>	<input type="checkbox"/>	<input type="checkbox"/>
5	<sup>1)</sup>			<input type="checkbox"/>	<input type="checkbox"/>	<input type="checkbox"/>	<input type="checkbox"/>	<input type="checkbox"/>
6	<sup>1)</sup>			<input type="checkbox"/>	<input type="checkbox"/>	<input type="checkbox"/>	<input type="checkbox"/>	<input type="checkbox"/>
7	<sup>1)</sup>			<input type="checkbox"/>	<input type="checkbox"/>	<input type="checkbox"/>	<input type="checkbox"/>	<input type="checkbox"/>
8	<sup>1)</sup>			<input type="checkbox"/>	<input type="checkbox"/>	<input type="checkbox"/>	<input type="checkbox"/>	<input type="checkbox"/>
9	<sup>1)</sup>			<input type="checkbox"/>	<input type="checkbox"/>	<input type="checkbox"/>	<input type="checkbox"/>	<input type="checkbox"/>
10	<sup>1)</sup>			<input type="checkbox"/>	<input type="checkbox"/>	<input type="checkbox"/>	<input type="checkbox"/>	<input type="checkbox"/>
11	<sup>1)</sup>			<input type="checkbox"/>	<input type="checkbox"/>	<input type="checkbox"/>	<input type="checkbox"/>	<input type="checkbox"/>
12	<sup>1)</sup>			<input type="checkbox"/>	<input type="checkbox"/>	<input type="checkbox"/>	<input type="checkbox"/>	<input type="checkbox"/>
13	<sup>1)</sup>			<input type="checkbox"/>	<input type="checkbox"/>	<input type="checkbox"/>	<input type="checkbox"/>	<input type="checkbox"/>
14	<sup>1)</sup>			<input type="checkbox"/>	<input type="checkbox"/>	<input type="checkbox"/>	<input type="checkbox"/>	<input type="checkbox"/>
15	<sup>1)</sup>			<input type="checkbox"/>	<input type="checkbox"/>	<input type="checkbox"/>	<input type="checkbox"/>	<input type="checkbox"/>
16	<sup>1)</sup>			<input type="checkbox"/>	<input type="checkbox"/>	<input type="checkbox"/>	<input type="checkbox"/>	<input type="checkbox"/>
17	<sup>1)</sup>			<input type="checkbox"/>	<input type="checkbox"/>	<input type="checkbox"/>	<input type="checkbox"/>	<input type="checkbox"/>
18	<sup>1)</sup>			<input type="checkbox"/>	<input type="checkbox"/>	<input type="checkbox"/>	<input type="checkbox"/>	<input type="checkbox"/>
19	<sup>1)</sup>			<input type="checkbox"/>	<input type="checkbox"/>	<input type="checkbox"/>	<input type="checkbox"/>	<input type="checkbox"/>
20	<sup>1)</sup>			<input type="checkbox"/>	<input type="checkbox"/>	<input type="checkbox"/>	<input type="checkbox"/>	<input type="checkbox"/>
21	<sup>1)</sup>			<input type="checkbox"/>	<input type="checkbox"/>	<input type="checkbox"/>	<input type="checkbox"/>	<input type="checkbox"/>
22	<sup>1)</sup>			<input type="checkbox"/>	<input type="checkbox"/>	<input type="checkbox"/>	<input type="checkbox"/>	<input type="checkbox"/>
23	<sup>1)</sup>			<input type="checkbox"/>	<input type="checkbox"/>	<input type="checkbox"/>	<input type="checkbox"/>	<input type="checkbox"/>
24	<sup>1)</sup>			<input type="checkbox"/>	<input type="checkbox"/>	<input type="checkbox"/>	<input type="checkbox"/>	<input type="checkbox"/>
25	<sup>1)</sup>			<input type="checkbox"/>	<input type="checkbox"/>	<input type="checkbox"/>	<input type="checkbox"/>	<input type="checkbox"/>
26	<sup>1)</sup>			<input type="checkbox"/>	<input type="checkbox"/>	<input type="checkbox"/>	<input type="checkbox"/>	<input type="checkbox"/>
27	<sup>1)</sup>			<input type="checkbox"/>	<input type="checkbox"/>	<input type="checkbox"/>	<input type="checkbox"/>	<input type="checkbox"/>
28	<sup>1)</sup>			<input type="checkbox"/>	<input type="checkbox"/>	<input type="checkbox"/>	<input type="checkbox"/>	<input type="checkbox"/>
29	<sup>1)</sup>			<input type="checkbox"/>	<input type="checkbox"/>	<input type="checkbox"/>	<input type="checkbox"/>	<input type="checkbox"/>
30	<sup>1)</sup>			<input type="checkbox"/>	<input type="checkbox"/>	<input type="checkbox"/>	<input type="checkbox"/>	<input type="checkbox"/>

<sup>1)</sup> Value is transferred from previous segment

Enter a new program			
Steps	Operation	Display	Comments
Press [MENU], turn to select [ENTER PROGRAM] and press to confirm			
Turn to select an empty program and press to confirm			The program number is shown in the menu bar
Program name: Change name: -> Print Do not change the name: -> Turn more			Change default name (e.g. "P01"): Turn to change flashing sign, press to confirm sign. <b>Press for 2 sec. to complete entry, the 1st segment is displayed.</b>
Press to confirm segment [S01]. Segment number is shown in the menu bar.			P01-S01 means: First segment [S01] of program 01 [P01]. A program can consist of several segments.
If necessary, turn to select the start temperature [TA] of the segment. This is necessary only in the first segment. Press to confirm.			The start temperature [TA] is a chosen temperature at which the program should begin. Normally, this setting does not have to be changed, as the furnace usually starts at the current temperature. In this case, simply press the jog dial to confirm.
Turn to enter the target temperature of the first segment. Press to confirm.			
Turn to select whether you wish to enter the time [TIME] or degrees per hour [RATE]. Press to confirm.			Enter the time [TIME] in the format hour:minute (hh:mm), and the [RATE] in degrees per hour (°/h).
Turn to enter the time [TIME] or degrees per hour [RATE] for the segment. Press to confirm.			



Enter a new program			
Steps	Operation	Display	Comments
Turn to select the extra functions. Press to confirm.			The number of extra functions depends on the features of the furnace (e.g. controlled exhaust air flap).
Turn to select the next segment and press to confirm.			The next segment is specified automatically.
Repeat the steps described above until you have entered all the segments. If you do not need another segment, do not enter a target temperature in the last segment ([END] is displayed) but save the program, as described in the next step.			
Extra functions set in the end segment remain set when the program is finished.			
Save the program: Press and hold the jog dial (2 sec.).			If you do not want to save the program, select [NO]. Alternatively, you can also press “Back”  to save the program.

## 8 Displaying, Entering or Changing Programs

The controllers have an efficient, easy to use program entry function. Programs can be entered or changed quickly with the convenient jog dial. Programs can be changed, exported or imported from a USB flash drive while the furnace is operating.

Instead of a program number, you can assign a name to the program. If a program is to be used as a template for a different program, it can be copied or deleted easily.

For simple, PC-supported program input and program import via a USB flash drive, please refer to “Preparing Programs on a PC with NTEdit”.

### 8.1 Displaying Programs

Prepared programs can be viewed without changing the program. To do this, carry out the following steps:

Program - Display			
Steps	Operation	Display	Comments
Select the menu level			
Select the program and confirm			The program number is shown in the menu bar

When you have selected this menu, the program can be displayed by turning the jog dial.

The program can also be started from this menu.

## 8.2 Entering the Programs





For automatic control of the furnace, enter a temperature curve to describe the required temperature pattern before you start the controller. This set temperature pattern is also described as the program or heating program.

All programs have freely configurable segments:

- B400/B410 = 5 programs/4 segments
- C440/C450 = 10 programs/20 segments
- P470/P480 = 50 programs/40 segments (39 segments + end segment)

From the overviews, simply press “Menu” to reach [ENTER PROGRAMS]. Press the jog dial to confirm, which opens program editing. From here, you can select all parameters of program entry one by one by turning the jog dial. If a parameter is to be changed, press the jog dial to change the value of the parameter.

For simple, PC-supported program input and program import via a USB flash drive, please refer to “Preparing Programs on a PC with NTEdit”.



Entering the Program			 SUPERVISOR
Steps	Operation	Display	Comments
Select the menu level			
Select and confirm program			The program number is displayed in the menu bar

When you choose the program using the jog dial, the menu icon starts flashing and indicates that more settings can be made by pressing the menu button. In this case, holdback mode can be set.



### Note

Holdback mode can be entered only with a C440/C450/P470 or P480. With a B400/B410, the mode is set to AUTO.

Steps	Operation	Display	Comments
If necessary, select holdback mode. Do this by pressing the menu key			Choose between [AUTO] and [MANUAL] See section "The Holdback Setting". The menu symbol in the display blinks.

The "holdback" is a function that can hold the program when, depending on the temperature, when it departs from the tolerance band. A distinction to draw between 2 operating modes:

- Holdback operating mode = [AUTO]

In the [AUTO] operating mode there are no effects of a holdback on the program except when switching over from ramps to dwell times. The program waits at the end of a ramp for the dwell time temperature to be reached. Once the dwell time



temperature is reached the controller jumps into the next segment and the processing is continued without further influence. The master thermocouple is observed or, if activated, the charge thermocouple. For controlled cooling, the master thermocouple is observed.

- Holdback operating mode = [MANUAL]

In the [MANUAL] operating mode a tolerance can be entered for every dwell time. If the temperature of the master zone (or of the charge thermocouple for charge control) departs from the band, the program is put on hold. The program is continued when the master zone is back in the band. If the band 0 °C is entered, the program is not held and is executed time-controlled, independent of the measured temperatures. This band does not operate in ramps and extends the dwell time when the temperature leaves the band. For controlled cooling, the master thermocouple is observed.



This operating mode is advisable, for example, with multiple zone control where the zones are arranged vertically.

Select the required holdback operating mode and press the jog dial to confirm.



Steps	Operation	Display	Comments
Editing the program name. By turning and pressing you can set the individual letters/numbers. Press longer to finalize the entry.			If you don't want to change the name, the entry can be skipped by turning further or, after having selected, by pressing longer.

Turn the jog dial to reach the next parameter. Press the jog dial to begin entering the program name. The letter that can be changed flashes. Confirm the letter to move to the next one. Press and hold the jog dial to finish entering the program name.



After entering the name of the program, if a charge thermocouple has been installed, the charge control can be activated.

Steps	Operation	Display	Comments
Optional: Turning the charge control on or off			This selection only appears if the option is available.

The charge control has major impacts on the actual controller. During a charge control, an offset is transferred from the charge thermocouple to the zone controller that changes the zone controller until the charge has reached the program setpoint. This finalizes the global entries of the program and the individual segments can be entered.

Sequence	Operation	Display	Comments
Selecting the segment in the menu bar			The program and segment display is in the upper section of the display. Here P01-S01 means: First segment [S01] of program 01 [P01]. One program can comprise several segments.



Subsequently, in the first segment, the starting temperature of the program can be selected. All the following starting temperatures result from the previous segment.

Steps	Operation	Display	Comments
Enter the start temperature [TA] of the program.			The start temperature [TA] is a any selected temperature, that specifies the starting point of the first segment. This need not be the ambient temperature. Please remember the possibility of assuming the current furnace temperature for the program start as the starting temperature



If the option "Take over actual value" is active, 0 °C can be entered. When the program is started, then, the current temperature value is always accepted as the start setpoint.

Do not enter a dwell time in the first segment. Use a temperature ramp to heat up to the dwell time and program the dwell time in the next segment. Otherwise the time starts to elapse immediately without the dwell time temperature having been reached.

If, for the holdback operation mode, [MANUAL] has been selected, the entry of the holdback band is displayed for dwell times.





Steps	Operation	Display	Comments
Only for dwell times and Holdback mode [MANUAL]: Set holdback band [HB] width.			Note: The holdback entry[HB] is only available for dwell times.

If, for example, a value such as "3 °" is entered, in the range +3 ° to -3 ° the temperatures are monitored and, if the value strays outside the band, the program is held. When "0 °" is entered, the program is not influenced. If the holdback value has been entered, the temperature target value can be adapted

Steps	Operation	Display	Comments
Enter target temperature of the segment			If "0 °" is entered for the target temperature, the following segments are deleted when the program is saved.



The target temperature is simultaneously the start temperature of the following segment.

Then a time (for dwell times and ramps) or a rate (for ramps) can be attributed to the segment.

Steps	Operation	Display	Comments
Selection of the ramp mode: Select the ramp entry [RATE] or time [TIME] Note: A change is only possible for ramps			The time is entered using the format hours:minutes (hh:mm)
Enter duration of the dwell time, and/or the duration or rate for ramps.		 	[TIME] is stated in the format hh:mm. The entry "INFINITE" (infinite dwell time) appears between 499:59 and 00:00. [RATE] is stated in the format °/h. The entry "STEP" (infinite rapid ramp) appears between 9999 and 0 °/h. Warning: For long dwell times and activated data recording the maximum recording time must be respected! If necessary, set the process data archiving to [24 H LONG TERM REC]



[TIME] flashes. Turn the jog dial to select the [RATE]. If you do this, instead of time, [°/h] is shown; in other words, an increase is possible. The corresponding value can then be set using the jog dial. Entering 499:59 for [TIME] generates an infinite hold time.

Depending on the features of the furnace, external, switchable functions, also called extra functions, are available.

Sequence	Operation	Display	Comments
Selecting the extra functions			The number of extra functions depends on how the furnace is equipped



Select and unselect the extra functions by turning the jog dial.

If the furnace is equipped with a variable-speed cooling fan, it can be used for controlled cooling (see section "Controlled cooling").

Drain	Operation	Display	Comments
Select the cooling function			Depending on the oven equipment.

This parameter entry is repeated until all the segments have been entered.



A special feature in the program input is the "End" segment. It allows the automatic repetition of the program and setting of extra functions after the end of the program.

Steps	Operation	Display	Comments
Set the behavior of the end segment: With [END] the program is simply ended. With [REPEAT] the program is started repeatedly from the beginning.			Extra functions set in this segment remain set after the end of the program, until the Start/Stop  has been pressed.

If [END] flashes, you can select the operating mode [REPEAT] by turning the jog dial. Then, after the “end” segment, the complete program is repeated over and over again and can be stopped only with the start/stop buttons.

You will now be asked to select the extra functions. The extra functions in this special segment will not be reset at the end of the program. The extra functions are not reset until the Start/Stop key has been pressed.

If all the parameters have been entered, decide whether you want to save the program or to leave it without saving. This dialog can be called up at any time by pressing the "Back" key repeatedly.

Steps	Operation	Display	Comments
Saving changes: Press the [Back] icon and select Save with the jog dial and confirm or press and hold the jog dial (max. 3 seconds)	 		If you do not want to save the program, select [NO].

Once the entry has been completed, the program can be started (see program start).

If for a longer period of time no key is pressed, the display automatically jumps back to the overview.

### 8.3 Preparing Programs on a PC with NTEdit

Entering the required temperature curve is simplified considerably by using software on the PC. The program can be entered on the PC and then be imported to the controller with a USB flash drive.

This is why Nabertherm offers a valuable aid with the freeware **NTEdit**.

The following features support you in your day-to-day work:

- Selecting your controller
- Filtering of extra functions and segments depending on the controller
- Setting extra functions in the program
- Exporting a program to a hard disk (.xml)
- Exporting a program to a USB flash drive for direct import into the controller
- Graphical display of the program sequence



**Note**

This software and the corresponding documentation for NTEdit can be downloaded at the following address:

**http://www.nabertherm.com/download/**

**Product: NTEdit**

**Password: 47201701**

The downloaded file has to be unzipped before you use it.

Before using NTEdit, read the instructions, which are also in the directory.

System requirements: Microsoft EXCEL™ 2007, EXCEL™ 2010 or EXCEL™ 2013 for Microsoft Windows™.





**Read the tutorials on the Internet**





To access the operating instruction quickly, scan the QR code with your smartphone or enter the Internet address in your browser:  
[www.nabertherm.com/tutorials/controller](http://www.nabertherm.com/tutorials/controller)  
 Apps to scan QR codes can be downloaded from the corresponding sources (app stores).



### 8.4 Deleting and Copying Programs

Besides the entry of programs, it is also possible to delete or copy them.

Deleting and Copying Programs			 SUPERVISOR
Steps	Operation	Display	Comments
Select the menu level and, by turning, select the function			
Select the program you want to copy			

Deleting and Copying Programs			 SUPERVISOR
Steps	Operation	Display	Comments
Select the target location of the copy procedure			
Editing the program name. By turning you can set the individual letters/numbers. Press longer to finalize the entry			If you do not want to change the name, the entry can be skipped

## 8.5 What is a Holdback?

A holdback is a temperature band around the program setpoint. Should the actual value drift outside this band the holdback function will pause the setpoint adjuster and remaining time – and maintain the current setpoint value – for as long as necessary for the actual value to return within the temperature band.

The holdback cannot be applied if the processes have to be completed following a precise time specification. The delay of a segment by a holdback is not acceptable, for example, when the actual value approaches the setpoint slowly or there are delay effects in multi-zone controls/charge controls.

Here, the holdback only impacts on the master zone. The other control zones are not monitored

The holdback monitoring is only possible in dwell times.

The charge thermocouple is the master zone for the holdback when the charge is controlled.

There are 2 modes for the holdback:

**Holdback = AUTO:** There are no effects of a holdback on the program except when switching over from ramps to dwell times. Here, the controller waits for the dwell time temperature to be achieved. The program waits at the end of a ramp for the dwell time temperature to be reached. Once the dwell time temperature is reached the controller jumps into the next segment and the processing is continued.

**Holdback = MANU:** A tolerance band can be entered for every dwell time. If the temperature of the master zone (or of the charge thermocouple for charge control) departs from the band, the program is put on hold. The program is continued when the master zone is back in the band. If the band 0 °C is entered, the program is not held and is executed time-controlled, independent of the measured temperatures.

This band does not operate in ramps and extends the dwell time when the temperature leaves the band.

If the value entered is "0", the program works "purely time-controlled". No influence of the program takes place.

### Parameter Entry:

In the program entry the operator can set the holdback basically to "Auto" or "Manual" immediately after entering the program name by pressing the menu key (programmed parameters). The blinking menu symbol calls the attention of operator to this entry option.



## 8.6 Changing a Running Program

A running program can be changed without stopping it. Please remember that only the segments after the current segment can be changed, unless you jump, using the [SEGMENT JUMP] function again to the desired point.

**Note:** With a manual segment leap it may happen that more than one segment is skipped per leap. This depends on the current temperature of the furnace (automatic application of actual value).







**Note**

The changes in a running program remain saved as long as the program is running or a power outage took place.

If the current segment is a ramp, the current actual value after the program change, is accepted as a setpoint and the ramp is continued at this point. If a current dwell time is changed, then a change in the running program has no impact. Only a manual segment jump into this segment results in the execution of a change in the dwell time. The changes on following dwell times are executed without any restrictions.

The following steps must be performed to change an active program:

Changing the program			 SUPERVISOR
Steps	Operation	Display	Comments
Turn the jog dial while the program is running.			
Menu [CHANGE ACTIVE PROGRAM]			

When a program is active only individual segments can be changed. Global parameters such as the holdback operating mode and charge control cannot be changed.

For further entry of the program please read the instructions regarding the segment entry in the section entitled "Entering or Changing Programs".









After saving the change, the program is continued at the time of the change.

### 8.6.1 Performing Segment Jumps

Besides changing a program, it is also possible to jump between the segments of a running program. This can make sense if, for example, a dwell time needs to be shortened.

**Note:** With a manual segment leap it may happen that more than one segment is skipped per leap. This depends on the current temperature of the furnace (automatic application of actual value).

The following steps must be taken to execute a segment step:

Carrying out a segment leap			 SUPERVISOR
Steps	Operation	Display	Comments
Turn the jog dial while the program is running.			A heating program must have been started.
Turn and press to select and confirm the [SEGMENT JUMP]			
Select the segment in the menu bar			The program and segment display is at the top of the display. P01-S01 means: first segment [S01] of program 01 [P01]. A program can consist of several segments.
Confirm the segment and also press to confirm the confirmation prompt			

## 8.7 Locking the Controller

If you want to prevent a running program from being interrupted intentionally or unintentionally, you can achieve this using a controller lock. The lock blocks any entries at the controller.







The operation can only be released by the [SUPERVISOR].

The following steps must be performed to lock the controller:

Locking the controller			 OPERATOR
Steps	Operation	Display	Comments
Turn the jog dial while the program is running			A heating program must have been started.
Turn and press to select and confirm [CONTROLLER LOCK]			When this has been confirmed, the controller can no longer be operated.
The controller lock is shown by an icon in the overview			Icon flashes

## 8.8 Unlocking the Controller

The following steps must be performed to unlock the controller:

Enabling the controller			 SUPERVISOR
Steps	Operation	Display	Comments
Turn the jog dial while the program is running.			A heating program must have been started.
Select the user [SUPERVISOR].			A heating program must have been started.
Confirm your selection by entering the password for the [SUPERVISOR].			When you have confirmed the password, the display changes to the overview and the icon for the controller lock disappears.

## 9 Process Documentation NTLog

This controller has an inbuilt USB interface for using a USB flash drive (no external hard disks or network drives).

Settings and programs can be imported and exported via this USB interface.

Another important function of this interface is saving process data for a current program on a USB flash drive.

It is unimportant whether the USB flash drive is inserted in the operating unit during the heating program or afterwards. Each time the USB flash drive is inserted, all files are copied from the operating unit to the USB flash drive (up to 16 files).



### Note

During the current program, the process data is saved cyclically in a file on the internal memory of the controller. At the end of the heating program, the file is then copied to the USB flash drive (the USB flash drive must be formatted (file system FAT32)).

Please remember that only a maximum of 16 heating programs can be saved to the memory of the controller. Once the memory is full, the first process data file is overwritten. So if you want to analyze all the process data, plug in the USB stick into the control unit, permanently or directly after the heating program.

The two files that are generated per heating program have the following file names:

[HOSTNAME]\ARCHIVE \ [DATE]\_[SERIALNUMBER-CONTROLLER]\_[SERIALNUMBER].CSV

### Example:

File: "20140607\_15020030\_0005.csv" and „20140607\_15020030\_0005.csv"

After 9999 is reached, the serial number of the file name starts again at 0001.

The files with the extension "CSV" are used for the analysis with NTGraph (Nabertherm tool for displaying NTLog files) and Excel™.

### Caution

Helpful tips about NTLog and NTGraph

For the presentation of NTLog process data files Nabertherm makes available the "NTGraph" for Microsoft Excel™ (freeware).

This software and the corresponding documents for NTlog and NTGraph can be downloaded at the following Internet address:

**<http://www.nabertherm.com/download/>**

**Product: NTLOG\_C4eP4**

**Password: 47201410**

The downloaded file must be unpacked before use.

Instructions for using NTGraph can be found in the manual that is also included in the directory.

System requirements: Microsoft EXCEL™ 2003, EXCEL™ 2010 or EXCEL™ 2013 for Microsoft Windows™.

### The following data are saved to the files:

- Date and time
- Charge Name
- File name
- Program number and name
- Serial number of the controller
- The heating program
- Comments regarding the course and result of the heating program
- Version of the display unit
- Controller name
- Product group of the controller
- Process Data

The process data is composed of the following constituents:

Process data table		
Process	Function	Description
Data 01	Program setpoint	Setpoint that is determined by the heating program that is entered
Data 02	Setpoint of zone 1	Setpoint for a zone. This consists of the program setpoint, the setpoint offset and the offset of the charge control.
Data 03	Temperature of zone 1	Measurement of the thermocouple for the zone
Data 04	Power of zone 1 [%]	Output of the controller for the zone in [0-100 %]
Data 05	Setpoint of zone 2	See above
Data 06	Temperature of zone 2	Measurement of the thermocouple for the zone or of a documentation thermocouple

Process data table		
Process	Function	Description
Data 07	Power of zone 2 [%]	See above
Data 08	Setpoint of zone 3	See above
Data 09	Temperature of zone 3	Measurement of the thermocouple for the zone or of a documentation thermocouple
Data 10	Power of zone 3 [%]	See above
Data 13	Temperature of the charge/documentation thermocouple	Measurement of the charge/documentation thermocouple
Data 14	Setpoint output of the charge control	Setpoint of charge controller. This consists of the program setpoint and the offset of the charge control.
Data 15	Temperature of the cooling thermocouple	Measurement of the cooling thermocouple
Data 16	Speed of the cooling fan [%]	Output of the controller for controlled cooling [0-100%]

Which data is available for your furnace depends on the furnace design. The data is stored without decimal place.



**Caution**

When you insert the USB stick, a symbol is displayed in the lower right of the display. As long as the control unit is writing or reading data, the symbol blinks. These procedure can last as long as 45 seconds. Wait until this symbol stops blinking before you pull out the USB stick!

For technical reasons, all the archive files on the controller are always synchronized. That is why this time can vary depending on the sizes of the files.

**IMPORANT: Do not connect here any PC, external harddrive or any other USB host/controller - You may damage both devices.**

USB stick			
Steps	Operation	Display	Comments
Plug the USB stick into the control unit.		 Symbol blinks	In the lower right a symbol for the USB stick is displayed.















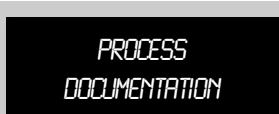

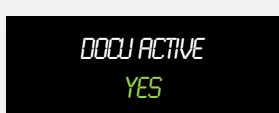

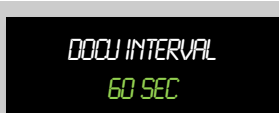

**Caution**

As long as the symbol for the USB stick is blinking, it must **not** be pulled out. Otherwise data may be lost.

### Parameters:

The process documentation NTLog can be adapted to the personal and process technical needs.

Parameters			 SUPERVISOR
Steps	Operation	Display	Comments
Select the menu level and, by turning, select settings menu			
Select, by turning, the [PROCESS DOCUMENTATION] menu			
Turn the documentation on or off			
Setting the interval between 2 writing procedures			Minimum setting 10 seconds. Nabertherm recommends an interval of 60 seconds to keep the data quantity as small as possible.
Selection of the modus for the end of the process documentation			Please observe the following instructions:
		<p>The parameter <b>[DOCU END]</b> determines when the recording of a process data file is ended.</p> <p><b>Here, 2 settings are possible:</b></p> <p><b>[PROGRAM END]</b> The recording is automatically ended at the end of the heating program. This is a standard setting</p> <p><b>[BELOW LIMIT]</b> The recording is not ended until the temperature falls below a temperature threshold [TEMP LIMIT]. This setting also contributes to recording the cooling procedures after the end of the heating program.</p>	
Change the temperature limit for the end of the process recording (default setting = 100 °C)			Not available if [DOCU END] was set to [BELOW LIMIT].

Parameters			 SUPERVISOR
Steps	Operation	Display	Comments
Setting the 24 h long term recording			A long-term recording should be selected if clearly more than 80,000 datasets (approx. 60 days at 60 second intervals) need to be written to a file. This can be true for infinite dwell times or very long programs. In this case, the USB stick must remain plugged in. A file is saved for each day.
			 ADMIN
Activating the USB interface			This function must be activated in order to use a USB stick.

**Note**

In case of long-term recording, observe the maximum recording time. A maximum of approx. 89,760 data records can be recorded. A new file is created each day.

If long-term recording is not selected, up to 5,610 data records are recorded in each file. If the heating program takes longer, a new file is created with no interruption to the heating program. Up to 16 files are written. Recording is then stopped.

**Caution**

Make sure that the date and time settings are correct before the first recording (see the section "Setting the Date and Time")

## 10 Setting the Parameters

### 10.1 Measurement Range Calibration

The measurement range from the controller to the thermocouple can exhibit measurement errors. The measurement range consists of the controller inputs, the measurement wires, sometimes terminals and the thermocouple.

If you discover that the temperature value on the controller display no longer agrees with the value of a comparison measurement (calibration), this controller offers the option of an easy matching of the measurement values for each thermocouple.

By entering up to 10 base points (temperatures) with the relevant offsets these temperatures can be matched very flexibly and precisely.

When an offset of a grid point is entered, the actual value of the thermocouple and the entered offset are added.

### Example:

- **Adaptation using a comparative measurement:** The control thermocouple outputs a value of 1000 °C. Calibration measurements near the control thermocouple return a temperature value of 1003 °C. By entering an offset of "+3 °C" at 1000 °C, this temperature is raised by 3 °C and the controller, then also returns a value of 1003 °C.
- **Adaptation using a transducer:** Instead of the thermocouple, a transducer supplies the measurement range with an actual value of 1000 °C. The display outputs a value of 1003 °C. The deviation is "-3 °C" from the reference value. Hence, the offset that must be entered is "-3 °C".
- **Adaptation using a calibration certificate:** On the calibration certification (for example for a thermocouple) there is, at 1000 °C, a deviation of "+3 °C" from the reference value. The correction is "-3 °C" between the display and the reference value. Hence, the offset that must be entered is "-3 °C".
- **Adaptation using a TUS measurement:** During a TUS measurement, a deviation of the display from the reference band of "-3 °C" is determined. Here, the offset that must be entered is "-3 °C".



#### Caution

The thermocouple calibration certificate does not take into account the deviations of the measurement range. Deviations of the measurement range must be determined by a measurement range calibration. The two values are added together to produce the correction values that need to be entered.



#### Caution

Please observe the instructions at the end of the section.

### The setting function in this instance follows specific rules:

- The values between two support points (temperatures) are linearly interpolated. That means that a straight line is projected between the two values. The values between the supporting points are then on this line.
- The values below the first support point (for example, between 0 and 20 °C) are located on a straight line that is connected (interpolated) with 0 °C.
- Values above the last supporting point (for example >1800 °C) are project further with the final offset (a final offset at 1800 °C of +3 °C is also used at 2200 °C)
- Temperature inputs for the support points must be in ascending order. Support points that follow gaps ("0" or a lower temperature for a support point) are ignored.



**Example:**

**Use from only one supporting point**

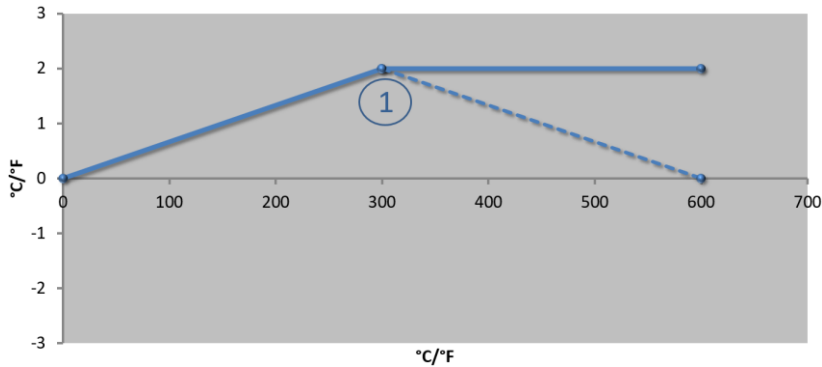

Similar to picture

No.	Meas. Point	Offset
1	300.0°	+2.0°
	0.0°	0.0°
	0.0°	0.0°
	0.0°	0.0°
	0.0°	0.0°
	0.0°	0.0°
	0.0°	0.0°
	0.0°	0.0°
	0.0°	0.0°

**Comments:** The offset is continued beyond the final supporting point. The gradient of the dashed line would be achieved by entering an additional line with an offset of 0.0 °C at 600.0 °C.

**Use of only one offset for several supporting points**

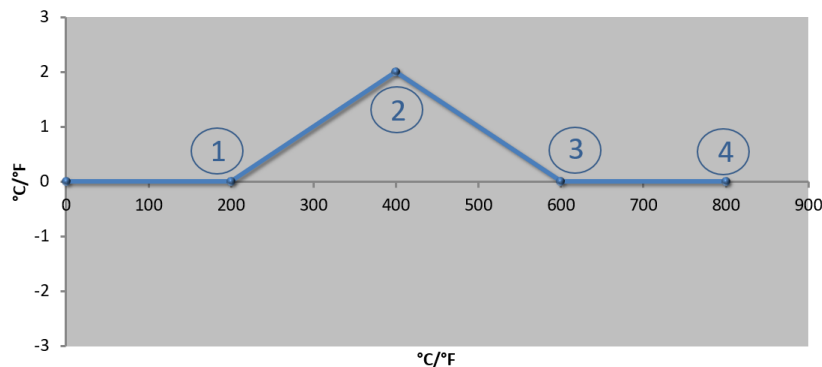

Similar to picture

No.	Meas. Point	Offset
1	200.0°	0.0°
2	400.0°	+2.0°
3	600.0°	0.0°
4	800.0°	0.0°
	0.0°	0.0°
	0.0°	0.0°
	0.0°	0.0°
	0.0°	0.0°
	0.0°	0.0°
	0.0°	0.0°

**Comments:** When several supporting points are entered, but only one offset, the result is that to the left and right of this supporting point the offset has the value "0". This can be recognized at the points 200 °C and 600 °C.

**Use of 2 supporting points**

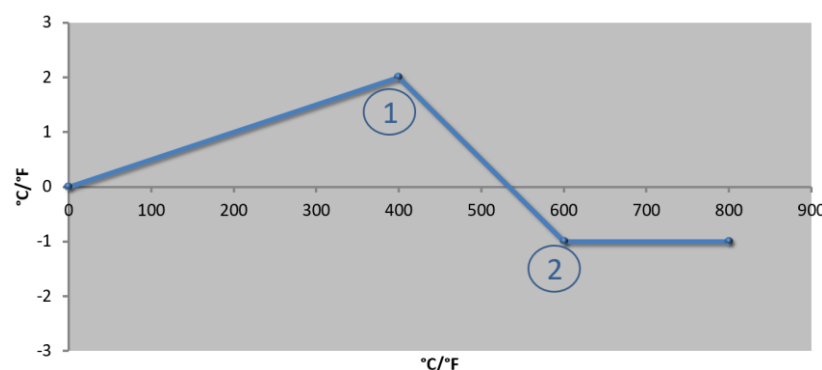

Similar to picture

No.	Meas. Point	Offset
1	400.0°	+2.0°
2	600.0°	-1.0°
	0.0°	0.0°
	0.0°	0.0°
	0.0°	0.0°
	0.0°	0.0°
	0.0°	0.0°
	0.0°	0.0°
	0.0°	0.0°
	0.0°	0.0°

**Comments:** If two supporting points are entered, each with an offset, there is an interpolation between the offsets (see

points 1 and 2).

### Use of only two offsets for several supporting points

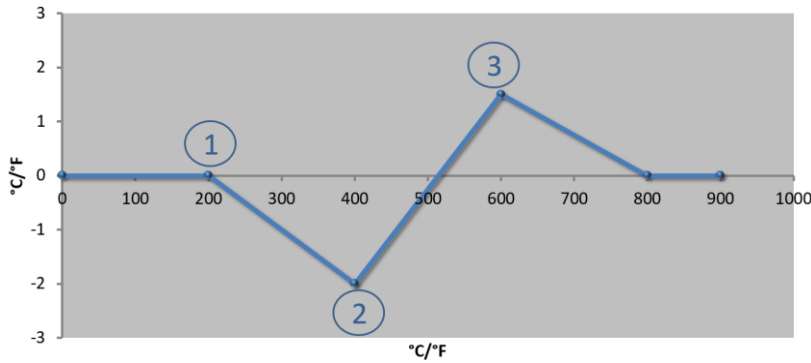

No.	Meas. Point	Offset
1	200.0°	0.0°
2	400.0°	-2.0°
3	600.0°	+1.5°
	800.0°	0.0°
	0°	0°
	0°	0°
	0°	0°
	0°	0°
	0°	0°

Similar to picture

**Comments:** Here, too, the range around the offsets entered can be eliminated again.

### Use of several supporting points with separated offsets

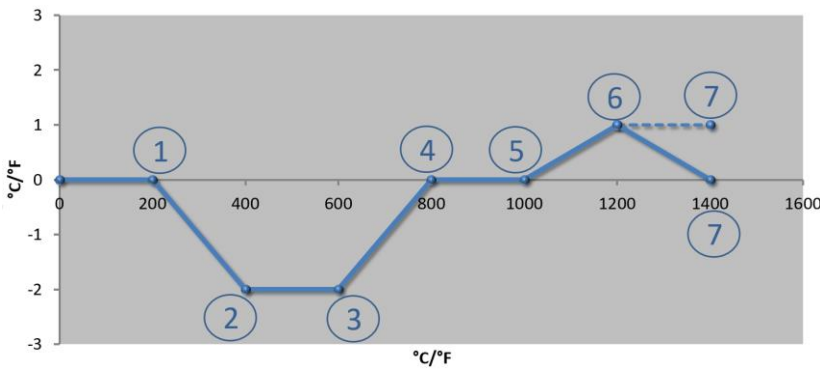

No.	Meas. Point	Offset
1	200.0°	0.0°
2	400.0°	-2.0°
3	600.0°	-2.0°
4	800.0°	0.0°
5	1000.0°	0.0°
6	1200.0°	1.0°
7	1400.0°	0.0°
	0.0°	0.0°
	0.0°	0.0°

Similar to picture

**Comments:** If the final line were left out, the gradient of the dashed line would reach (1400.0 °C). The offset would then continue beyond the final supporting point.





#### Notice











This function is intended for setting the measurement section. If deviations outside the measurement section are to be balanced out, for example, temperature uniformity measurements inside the furnace, the actual values of the corresponding thermocouples are falsified.

We recommend that you create the first base point at 0 ° with an offset of 0 °.

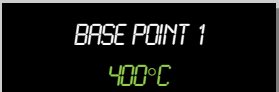
When you have set a measuring point, you must always carry out a comparison measurement with an independent measurement device. We recommend that you document and file changed parameters and comparison measurements.

The following steps must be performed to set the measurement range calibration:

Setting the Measurement Range Calibration			ADMIN
Steps	Operation	Display	Comments
Select the menu level and, by turning, select settings menu	 		

Setting the Measurement Range Calibration			ADMIN
Steps	Operation	Display	Comments
Select by turning the menu [CALIBRATION]			
Select the menu [BASE POINTS]			
Setting the base points 1-10			Determine based on the base points for which temperature an offset should apply. The number of base points can be freely selected (up to 10).
Selecting the zone			The selection depends on the furnace's features.
Setting the offset of the base points 1-10			
Saving			The data entered is saved automatically when the page is closed or when the measurement point is changed. After the data has been saved, call up the page again and check it to make sure that all the changes have been correctly entered.

## 10.2 Control Parameters

Control parameters define the behavior of the controller. For example, the control parameters influence the speed and accuracy of control. This allows users to adjust the controls to suit their particular requirements.

This controller provides a PID controller. The output signal of the controller consists of 3 parts:

- P = proportional portion
- I = integral portion
- D = differential portion

### Proportional Portion

The proportional portion is a direct reaction to the difference between the setpoint and the actual value of the furnace. The larger the difference, the larger the P-portion. The parameter that influences this P-portion is the parameter "X<sub>p</sub>".

Here the following applies: The larger the "X<sub>p</sub>", the smaller the reaction to the deviation. So it acts inversely proportional to the control deviation. At the same time, this value describes the deviation, for which the P-portion rises to = 100 %.

Example: A P controller should, for a control deviation of 10 °C, output a power of 100 %. X<sub>p</sub> is therefore set to "10".

$$Power [\%] = \frac{100\%}{XP} \cdot Deviation [^{\circ}C]$$

### Integral Portion

The integral portion grows as long as a control deviation is present. The speed at which this portion grows is determined by the constant  $T_N$ . The bigger this value is, the more slowly the I-portion increases. The I-portion is set using the parameter  $[T_I]$  unit:  $[Seconds]$ .

### Differential Portion

The differential percent reacts to the change in the control deviation and works against it. If the temperature in the furnace approaches the setpoint, the D-portion acts against this approach. It "dampens" the change. The D-portion is set using the parameter  $[T_D]$  unit:  $[Seconds]$ .

The controller calculates a value for each of these percentages. Then all three percentages are added together and the results is the power output of the controller for this zone in percent. Whereby, the I- and D-portions are each limited to 100 %. The P-portion is not limited.

### Display of the Controller Equation

$$F(s) = \frac{100\%}{XP} \cdot \left[ 1 + \frac{1}{T_N \cdot s} + \frac{T_v \cdot s}{T_{cyc}} \right]$$

### Integrating PID parameters from Controllers B130/B150/B180/C280/C290/P300-P310 (Index 2) for Series 400 Controllers (Index 1)









The following factors must be used to integrate the parameters:





$$xp_1 = xp_2$$

$$Ti_1 = Ti_2$$

$$Td_1 = Td_2 \times 5.86$$

The following steps must be taken to set the control parameters:

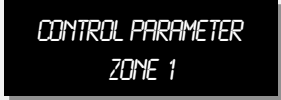
Setting the Control Parameter			 SUPERVISOR
Steps	Operation	Display	Comments
Select the menu level and, by turning, select settings menu			
Select, by turning, the [CONTROL PARAMETER] menu			
Select the [BASE POINTS] menu			
Setting the base points 1-10			Determine, using the base points, for which temperature range the parameters should be set. The number of base points can be freely selected (up to 10).

Setting the Control Parameter			 SUPERVISOR
Steps	Operation	Display	Comments
Selecting the zone			The selection depends on the furnace's features. Instead of [ZONE 1], in a single-zone furnace the designation [HEATING] is used.
Parameter values the offset of the base points 1-10			Repeat this entry for $T_N$ and $T_V$ .
Saving			The data entered is saved automatically when the page is closed or when the measurement point is changed. After the data has been saved, call up the page again and check it to make sure that all the changes have been correctly entered.



#### Caution

The I-portion is only enlarged until the P-portion has reached its maximum value. From then on the I-portion is no longer changed. In certain situations, this can prevent major overshooting.



#### Caution

The setting of the control parameters is similar to the Nabertherm controller B130/B150/B180, C280 and P300-P330. After a replacement with a new controller, controller settings can be taken over in the first step and, then, optimized.

## 10.3 Properties of the Controls

This section describes how to adjust integrated controllers. Depending on the features, controllers are used for zone heating, charge control and controlled cooling.

### 10.3.1 Smoothing

A heating program usually consists of ramps and dwell times. Overshooting is a likely possibility when the program progresses from one segment to the next. In order to dampen this tendency to overshoot, the ramp can be "smoothed" just prior to the transition into the dwell time.

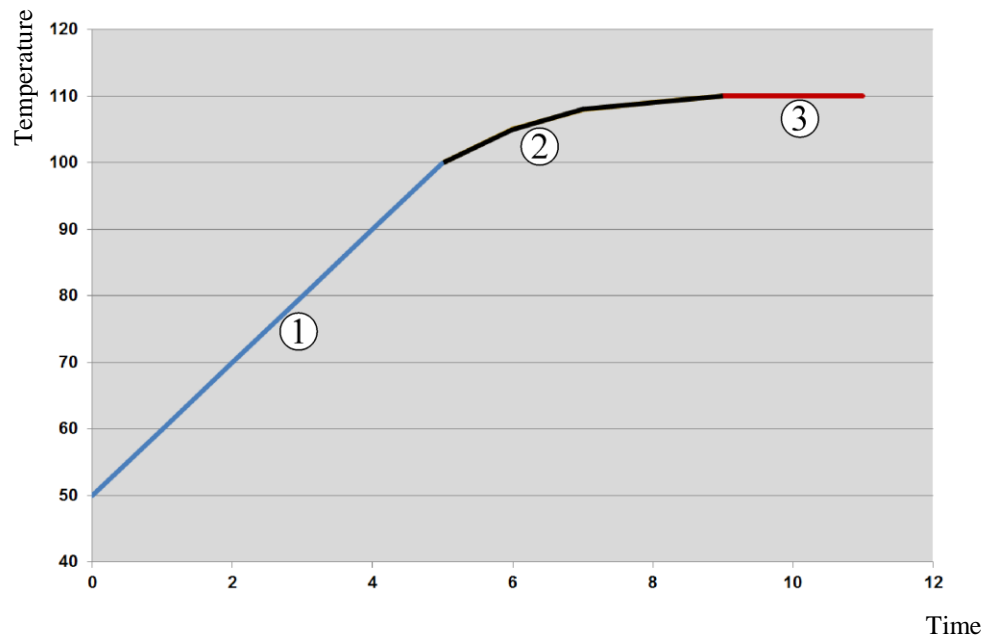

Fig. 7: Smoothing the ramp time







Range	Explanation
1	Normal course of the ramp
2	Smoothed range of the ramp
3	Normal dwell time



**Caution**

The ramp time can be extended when this function is activated, depending on the smoothing factor.

The following steps must be performed to set the smoothing parameters:

Setting the Smoothing			ADMIN
Steps	Operation	Display	Comments
Select the menu level			
Select, by turning, the [CONTROL] menu			
Select the [SMOOTHING] menu and select the smoothing factor			
Saving			The changes are automatically saved after you leave the menu.



### Caution

Calculation of the smoothing:

In case of a setpoint jump, the setpoint reaches, with a smoothing time of 30 seconds, after 30 seconds, 63 % of the target setpoint and, after 5 x 30 seconds, 99 % of the target setpoint.







**Equation:**

$$\text{Set value } (t) = 1 - e^{-t/\tau}$$

### 10.3.2 Heating Delay

If a furnace is loaded hot and with the door open, the cooling of the furnace will result in intensive reheating and overshooting after the door has been closed.

This function can delay the switching on of the heating so that the heat stored in the furnace first raises the temperature in the furnace again. If the heating switches on again after the delay time, the heating need not reheat the furnace as much and overshooting is avoided.

Setting the Heating Delay			ADMIN
Steps	Operation	Display	Comments
Select the menu level			
Select, by turning, the [CONTROL] menu			
Select the [HEATING DELAY] menu and set the delay time			
Saving			The changes are automatically saved after you leave the menu.



#### Caution

In order to be able to use this function the door switch signal ("Door closed" = "1" signal) must be connected to an input of the controller module. The setting of the corresponding input can only be performed in the service level and, hence must be set before the controller leaves the factory.

### 10.3.3 Manual Zone Control

It is possible that for furnaces with 2 heating circuits that do not have their own multi-zone control, different output powers are needed.

Using this function you can individually adapt the power of two heating circuits to the process. The controller has two heating outputs whose ratio in relation to each other can be set differently by the optional reduction of one output power. When shipped from the factory, both heating outputs are set to 100 % output power.

The setting of the ratios of the two heating circuits and their output powers are shown in the following table:

Display	0	10	20	30	40	50	60	70	80	90	100	110	120	130	140	150	160	170	180	190	200
A1 in %	0	10	20	30	40	50	60	70	80	90	100	100	100	100	100	100	100	100	100	100	100
A2 in %	100	100	100	100	100	100	100	100	100	100	100	90	80	70	60	50	40	30	20	10	0

#### Example:

1) At the setting "200", the furnace is heated only through output 1 (A1), for instance for a furnace for fusing applications, if only the ceiling heater is to be used and the side or floor









heater is to be turned off. Note that when operating with reduced heating power, the furnace may no longer be able to reach the maximum temperature specified on the type plate!

2) At setting "100", the furnace is operated with both heat outputs without reduction, for instance for an even temperature distribution when baking clay and ceramics.

3) At setting "0", output 1, for instance, the ceiling heater in fusing furnaces, is turned off. The furnace is heated only through the heater attached to output 2 (A2), e.g. the side and floor (see the furnace description). Note that when operating with reduced heating power, the furnace may no longer be able to reach the maximum temperature specified on the type plate!

The settings can only be saved globally and not program-dependent.

The following steps must be performed to set the function:

Setting the Zone Control			 ADMIN
Steps	Operation	Display	Comments
Select the menu level			
Select, by turning, the [CONTROL] menu			
Select [OFFSET MAN ZONE] and sset the offset			
Saving			The changes are automatically saved after you leave the menu.



**Caution**

Consult the furnace directions to determine which output (A1) (A2) is responsible for which heating range. For furnaces with two heating circuits, Output 1 is always the upper and Output 2 is always the lower heating circuit

### 10.3.4 Integrating the actual value as setpoint for the program start

Application of the actual value is a useful function to shorten heating up times.

Normally, a program starts at the start temperature that was entered in the program. If the furnace is below the start temperature of the program, the specified ramp is still started and the furnace temperature is not applied.

When deciding the temperature at which it will start, the controller always bases its decision on which temperature is higher at that time. If the furnace temperature is higher, the furnace starts at the current furnace temperature; if the start temperature set in the program is higher, the program starts with the temperature that is set there.

This function is switched on when the controller is delivered.







With segment leaps actual value application is always activated. Therefore, segments may be skipped with segment leaps.

### Example:

A program with a ramp from 20 °C to 1500 °C is started. The furnace still as a temperature of 240 °C. With activated take over actual value the furnace does not start at 20 °C but at 240 °C. The program can be substantially shortened.

This function is also used for segment steps and program changes in a running heating program.

The following steps must be performed to activate or deactivate the automatic take over value:

Activating/Deactivating Automatic Take Over Value			 ADMIN
Steps	Operation	Display	Comments
Select the menu level			
Select, by turning, the [CONTROL] menu			
Select the [TAKE OVER ACTUAL VALUE] menu and select the offset			
Saving			The changes are automatically saved after you leave the menu.

### 10.3.5 Controlled Cooling (option)

A furnace can be cooled in various ways. Such a cooling process can be controlled or uncontrolled. An uncontrolled cooling takes place at a fixed speed of the cooling blower. The controlled cooling also processes the temperature of the furnace and can set the appropriate cooling intensity anytime via a variable speed control or flap setting.. A controlled cooling is necessary if you want the furnace to follow a linear cooling ramp that is faster than the natural cooling of the furnace. This can always only occur in the physical limits of the furnace.

This controller enables such a controlled cooling to be implemented. Moreover, in a heating program, separate for each segment, the controlled cooling can be turned on or off. This assumes that the cooling in furnace has been prepared and the controller has been enabled (menu [Service]). Otherwise, this option is not visible in the program entry screen.

We recommend activating the cooling only in a cooling ramp (falling set value)

The controlled cooling is realized with the help of a tolerance band around the setpoint (see the figure below). This tolerance band consists of 2 limit values that enclose a monitoring range.

This range is uses as a hysteresis when switching between heating and cooling. The range should not be too large. A range of 2 - 3 °C has proved to be practical.

If the furnace temperature exceeds the upper band (1), cooling is activated (a fan for example) and the heating is switched off. If, during cooling, the furnace temperature falls below the setpoint (2), the cooling is switched off.

If the furnace temperature is below the lower band (3), the heating is reactivated. If, during heating, the furnace temperature rises above the setpoint again (4), the heating is switched off completely.

In addition, if the band is exceeded during cooling, a release output is switched on, for example, to activate a fresh-air fan.

If there is a malfunction in the cooling thermocouple during active cooling, the system switches over to the thermocouple of the master zone.

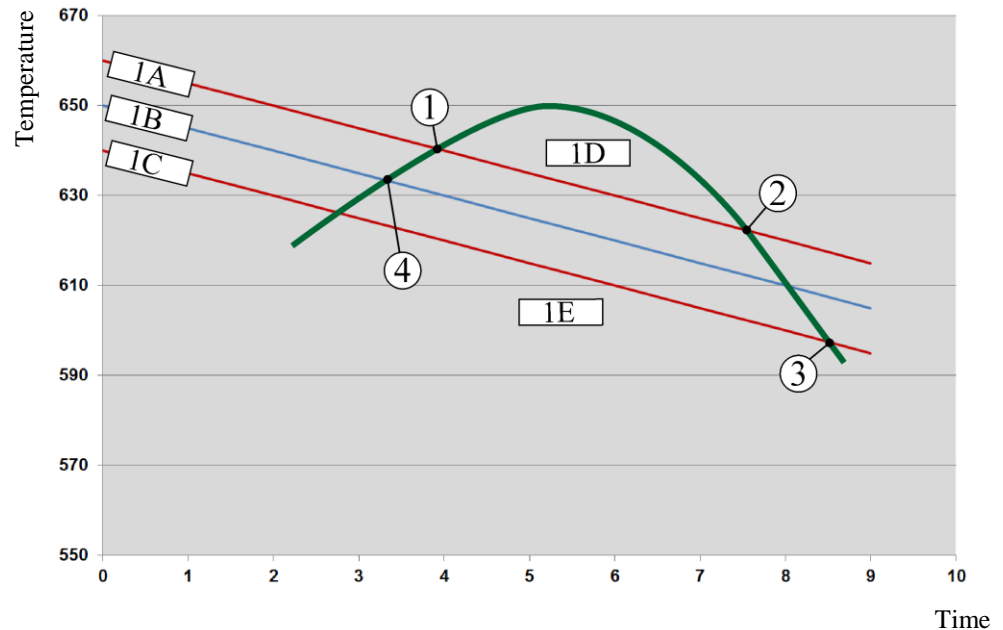

1A = upper band, 1B = setpoint, 1C = lower band, 1D = cooling, 1E = heating

Fig. 8: Switching between heating and cooling

**Note**

When the switchover from heating to controlled cooling is made, the I and D parts of the controller are also deleted.

To observe the control parameters of controlled cooling, please read “Information Menu -> Display PID Output”.

For controlled cooling, the thermocouple in the set master zone or a cooling thermocouple connected especially for controlled cooling is decisive (this depends on the furnace model). Documentation thermocouples or thermocouples from additional zones are not considered here. This applies also if charge control is active.









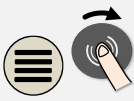

If controlled cooling is selected for a program segment, the zone thermocouple is switched to the cooling thermocouple for the complete segment. If no cooling thermocouple is connected, the thermocouple from the master zone is used for controlled cooling.

With active controlled cooling with a separate cooling thermocouple, the display in the main overview is switched to the temperature of the cooling thermocouple.

In the process documentation, the cooling temperature (with or without a separate cooling thermocouple) is always recorded parallel to the control thermocouple and the cooling output.

The controlled cooling can be parametrized in the **[SETTINGS]** menu.

This is done by performing the following steps:

Controlled cooling			ADMIN
Steps	Operation	Display	Comments
Select the menu level and turn to select the function [SETTINGS]			
Select the menu [CONTROL]			
Select the menu [CONTR COOLING] and switch controlled cooling on or off			This parameter is visible only if controlled cooling is available. Activate controlled cooling in order to enter it in the program.
Set the limit value for heating			The value is entered in Kelvin.
Set the limit value for cooling			The value is entered in Kelvin.
Changes do not have to be saved			Press the [Back] icon to go back to the overview

### Behavior in Case of Error

If the cooling thermocouple is defective, the thermocouple in the master zone is used. The temperature in the zone with the defective thermocouple is shown with "-- °C".

### 10.3.6 Start-Up Circuit (Output Limit)











A temperature control always reacts to a deviation between setpoint and the actual temperature value in the furnace. If this difference is large, the controller attempts to reduce this difference by means of greater heating power. This can lead to damage to the charge or the furnace.

This can have, for example, the following reasons:

- Use a thermocouple with major imprecision in the lower temperature range (for example type B)
- Use of pyrometers that in the lower temperature range do not deliver a measurement value
- Use of thermocouples with heavy-duty protective tubes and, hence, longer delay time

In order to limit the power peaks of the heating system in the lower temperature range in these cases, you are provided with the function "Start-Up Circuit/Output Limit". With this function you can limit the controller output for the heating to a specified temperature [LIMIT TEMPERATURE] to a specific output [MAX POWER]. Independent of the set setpoint, the furnace does not heat up with more power than in the startup circuit.

The following steps must be performed to set the startup circuit/power limit:

Setting the startup circuit/output limit			ADMIN
Steps	Operation	Display	Comments
Select the menu level and, by turning, select the function [SETTINGS]			
Select the [CONTROL] menu			
Select the [STARTUP CIRCUIT] menu and turn on or off the startup circuit			
Enter the limit temperature			
Enter maximum power in [%]			
The changes need not be saved.			Press the [Back] symbol to return to the overview

The startup circuit analyzes the following thermocouples:

- For a single-zone control: The control thermocouple is monitored
- For a single-zone control with charge control: The control thermocouple is monitored
- For a multi-zone control: All the zones are monitored individually. If a zone is below the limit temperature, the output power of the corresponding zone is limited correspondingly.
- For a multi-zone control with charge control: In this combination, the startup circuit behaves like a multi-zone controller.

### 10.3.7 Self Optimization

The behavior of controllers is determined by control parameters. The control parameters are optimized to a specific process behavior. To allow furnace operation to be as rapid as possible other parameters are used than those for an operation that is as precise as possible. To simplify this optimization, this controller offers the option of an automatic optimization, self-optimization. This does not replace the manual optimization and can only be used for single-zone furnaces, not multi-zone furnaces.

The control parameters of the controller have already been set at the factory for an optimum control of the furnace. If the control behavior must be adapted for your process, you can improve the control behavior by means of a self-optimization.

The self-optimization takes place in a specific sequence and, in addition, can only be performed, each time, for one temperature [OPT TEMPERATURE]. The optimization of several temperatures can only be performed one after another.

Start the self-optimization only when the furnace is cooled down ( $T < 60\text{ }^{\circ}\text{C}$ ), since otherwise false parameters are calculated for the control section. First enter the optimization temperature. The self-optimization is performed in each case at approx. 75 % of the set value to prevent a destruction of the furnace, for example for the optimization of the maximum temperature.

For some models, the self-optimization can take longer than 3 hours depending on the type of furnace and temperature range. The control behavior can be worsened by a self-optimization in other temperature ranges! Nabertherm assumes no liability for damages that are caused by manual or automatic change in the control parameters.

For this reason, check the control quality after autotune by operating the furnace without charge.



**Note**

Execute the autotune, if necessary, for several temperature ranges. Autotunes in lower temperature ranges ( $< 500\text{ }^{\circ}\text{C}/932\text{ }^{\circ}\text{F}$ ) can return extreme values depending on the calculation procedure. Correct these values, as necessary, by a manual optimization. Always check the returned by performing a test run.







The following steps must be performed to launch a self-optimization:

Start Self-Optimization			ADMIN
Steps	Operation	Display	Comments
Select the menu level and, by turning, select the function [SETTINGS]			
Select the [CONTROL] menu			
Select the [SELF OPTIMIZE] menu			
Start Self-Optimization			After confirmation, the controller starts to heat the furnace to the pre-set temperature.

If self-optimization was started, the controller heats to 75 % of the optimization temperature at full power. The heating process is then stopped and restarted at 100 % power. This procedure is carried out twice. Self-optimization is then finished.

After the autotune has been completed, the controller ends the heating and enters the calculated control parameters but not yet into the corresponding base point of the control parameters.

To save the calculated parameters, open the autotune menu again and check the parameters. Then you can select the base point in the same menu in which you want to copy the parameters.

Autotune: Check and Save Parameters			ADMIN
Steps	Operation	Display	Comments
Browse in the menu for autotune			
Check control parameters xp, Tn, Tv			
Import checked control parameters into the selected base point.			

### 10.3.8 Charge Control

The cascade, charge or melting bath control system is a combination of two control circuits which permits the temperature measured directly at the product being treated to be adjusted very precisely and rapidly dependent on the furnace chamber heating. When the charge control is turned on (cascade control) the temperature is measured by an additional thermocouple directly at the charge, for example in an annealing box, and controlled in relation to the furnace temperature.

#### Operation with Charge Control (cascade control)

When the charge controller (cascade) is turned on, both the charge temperature and the furnace chamber temperature are measured. A setpoint offset is generated for the furnace chamber, corresponding to the amount of the control deviation. This achieves a substantially quicker and more precise temperature control at the charge.

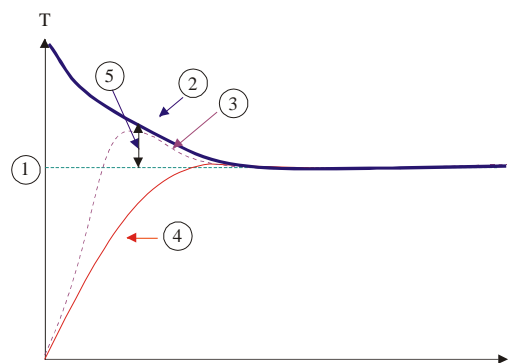

- ❶ Setpoint charge
- ❷ Setpoint furnace chamber
- ❸ Actual value furnace chamber
- ❹ Actual value charge/tank
- ❺ Setpoint offset

#### Operation with Charge Control (cascade control)

When the charge control (cascade) is switched off only the furnace chamber temperature is measured and corrected. Since the charge temperature in this context has no influence on the regulation, it approaches the program setpoint more slowly.

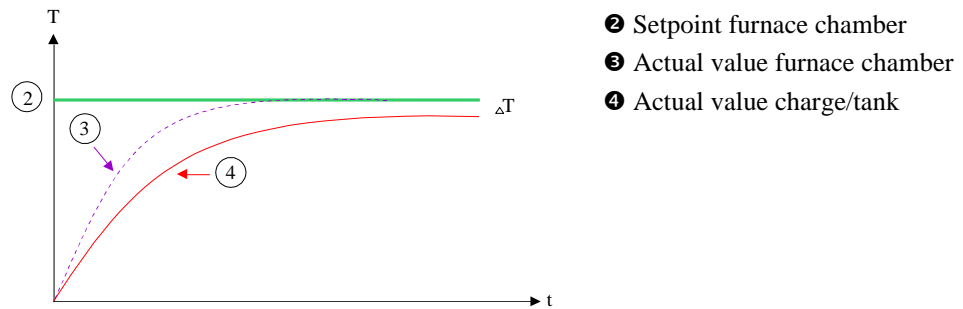

As explained in the previous paragraphs, the charge controller influences the furnace chamber controller to compensate the deviation between the thermocouple at the heating elements and the thermocouple at the charge (e.g., in the middle of the furnace). This compensation must be limited so that the furnace does not begin to vibrate.

The following parameter can be adapted for this purpose:

### Maximum Negative Output

The maximum negative offset that is transferred from the charge controller to the heating controller/zone controller. Hence, the setpoint of the heating zone cannot become smaller than:

- Heating setpoint = program setpoint – maximum negative offset.

### Maximum Positive Output

The maximum positive offset that is transferred from the charge controller to the heating controller/zone controller. Hence, the setpoint of the heating zone cannot become greater than:

- Heating setpoint = program setpoint + maximum positive offset.

### No I-Portion in Ramps

In ramps it is possible that the I value (integral portion of the output) of the charge controller slowly builds up a lasting control deviation. For the transition into the dwell time this cannot fall rapidly enough and the result may be an overshoot.

To avoid this effect, a build-up of the I-portion of the charge controllers in ramps can be deactivated.

















### Example:

If for the charge setpoint 500 °C is pre-set, the furnace chamber can, for an optimum control, accept a setpoint of 500 °C + 100 °C, i.e. 600 °C. The result is that the furnace chamber can heat up the charge very rapidly.

Depending on the process and the charge, it may be necessary to change the offset values. For example, a too sluggish control can be accelerated by a higher offset, or a too rapid control can be slowed down. However, the offset should only be changed after consultation with Nabertherm since the control behavior is largely determined by the control parameters and not by the trim.



The following steps must be performed to set the charge control:

Setting the Charge Controller			ADMIN
Steps	Operation	Display	Comments
Select the menu level and, by turning, select the function [SETTINGS]	 		
Select the menu [CONTROL]			
Select the menu [CHARGE CONTROL]			
Set the maximum negative output			The entry is made in Kelvin
Set the maximum positive output			The entry is made in Kelvin
Switching on or off the I-portion of the PID controller in the ramps with the function [I-BLOCK FOR RAMPS]			
Select whether a negative output of the charge controller should also be allowed outside of the cooling ramps. Parameter text: [BLOCK LOWERING]			Default: [YES] Here, select only [NO] if you are certain what the consequences for the process are. Follow the instructions below.
The changes need not be saved			Press the "Back" symbol to return to the overview

#### Additional Instructions:

- When the charge control is active, the large temperature display of the main overview is switched to the charge thermocouple.
- The error analyses that are part of the charge control (for example, a pulled charge thermocouple), are only activated if the charge control is activated in a running program. If the charge thermocouple has an error, a switchover is made to the master zone thermocouple and an error message is outputted. A program interrupt does not take place.
- The switchover between the control parameters, for example from Support point 1 to Support point 2 conforms with the program setpoint, not with the actual temperature value in the furnace.

### Limiting the Offset of the Charge Controller [BLOCK LOWERING]:

Charge control does not directly affect the heating; it influences the heating controller indirectly via an offset on the program setpoint. This offset (output) is simply added to (positive offset) or subtracted from (negative offset) the setpoint. A negative offset is usually permissible only with decreasing (negative) ramps, as otherwise fluctuations would occur.

Certain furnace series (such as tube furnaces) need the option that the negative offset is also active during hold times or heating ramps. Otherwise, it could happen that the program does not go to the next segment.

This release can be granted via the parameter [BLOCK LOWERING] = [NO] in the charge control settings. This adaption should only be performed if it is necessary for the process.

### 10.3.9 Setpoint Offsets for Zones

With multi-zone furnaces it may be necessary to give the zones different setpoints. Normally, all the furnace zones work with the setpoint that is generated from the heating program. For example, if a zone does not have 600 °C has a setpoint as the other zones do, but instead only 590 °C, this is possible using the "Zone Offset Set Value".

The following steps must be performed to enter setpoint offsets for one or several zones:

Entering the set value offset for one or several zones			 ADMIN
Steps	Operation	Display	Comments
Select the menu level and, by turning, select the function [SETTINGS]	 		
Select the [CONTROL] menu			
Select the [ZONE OFFSET SET VALUE]			
Select the zone and its offset			The entry is made in Kelvin
The changes need not be saved			Press the [Back] symbol to return to the overview

## 10.4 User Administration

The user administration allows certain operating functions to be protected by a password. This means that an operator with basic rights cannot change any parameters.

**For this purpose 4 user levels are available:**

User	Description	Passwords (default setting)
<b>OPERATOR</b>	Normal user	00001 <sup>1</sup>
<b>SUPERVISOR</b>	Process officer	00002 <sup>1</sup>
<b>ADMIN</b>	Technical officer	00003 <sup>1</sup>
<b>Service</b>	Only for Nabertherm Service	*****
<b>Resetting the Passwords</b>	Available on request	*****

<sup>1</sup> We recommend changing the passwords for safety reasons when the furnace is started up for the first time. For this purpose you have to switch into the user level "ADMIN" where you can change the password for the relevant user level (see "Adapt User Administration to Needs").

**The rights of the individual users are assigned as follows:**

User	Assignment of rights
<b>OPERATOR</b>	
	View overviews
	Segment leap
	Operate extra functions manually
	Switch on controller lock
	Load, view, start, hold and stop the program
	Select language
	Initiate export files
	Log on user and reset passwords
	Read out the information menu
<b>SUPERVISOR</b>	<i>All rights of the [Operator], plus</i>
	Change current program
	Enter, delete, and copy programs
	Unlock controller
	Upload process documentation
<b>ADMIN</b>	<i>All rights of the [Supervisor], plus</i>

User	Assignment of rights
	Enable/disable interfaces (USB/Ethernet)
	Calibration
	Controller smoothing
	Set delay after door is closed
	Set control parameters
	Set manual zone control
	Enable/disable actual value application
	Set controlled cooling
	Set start-up circuit
	Carry out self optimization
	Set zone offsets
	Set charge control
	Change user administration
	Change extra functions
	Change alarm functions
	Change gradient monitoring
	System: Temperature unit, date and time format
	Set interfaces
	Set power failure behavior (only operating mode)
	Import parameters and programs via USB flash drive
	Set date and time
	Log on modules







### User Registration



#### Note - Quick User Selection











Log-on a user quickly by exiting the main menu and then pressing the info menu key  for several seconds until the user selection is displayed. Then select the corresponding user and, then, enter the password.

You can log-on a user without using the quick selection by carrying out the following steps:

Log-On of a User (user level)			 OPERATOR/SUPERVISOR/ADMIN
Steps	Operation	Display	Comments
Press the information key approx. 3 seconds to log-on, select the user and confirm the selection.	 		
Entering the password			After an incorrect password is entered, the warning [PASSWORD NOT CORRECT] is outputted.

### Adopting User Administration by Needs

To adapt the user administration to their needs, please perform the steps described below. Here, the time can be set after which the user is automatically logged off again. Equally, the user level can be set to which the controller returns after the log-off [STANDARD USER]. That means, which functions are available without having to register.

Change user administration according to requirements			 ADMIN
Procedure	Operation	Display	Comments
If required, change the password of a user. Select the user and enter the new password twice.		  	
Activate [OPERATION LOCK]: Select this parameter to activate a basic operation lock for the operator.			See "Continuous Controller Lock".
After making the change, log off again			
If necessary, reset the passwords of all users with [PASSW RESET CMPL].			Request the necessary password from Nabertherm Service.
Changes do not have to be saved			Press the [Back] icon to go back to the overview.

## 10.5 Controller Lock

### 10.5.1 Controller Lock when Program Is Running

Another type of access limitation is the controller lock. It can always be activated after the start of a heating program. Its purpose is to prevent intentional and unintentional interventions in the running of a heating program.

Controller lock			 OPERATOR
Steps	Operation	Display	Comments
Turn the jog dial while the program is running.			A heating program must have been started.
Turn and press to select and confirm [CONTROLLER LOCK]			
Enable controller lock			
			 SUPERVISOR
Disable controller lock			You will be asked to enter a password. Enter the password and confirm it.

## 10.6 Controller Lock

To prevent operation of the controller permanently, use the function [Operation Lock]. This prevents any access to the controller, even if no program has been started.

The supervisor can activate the operation lock in user administration with the parameter [Operation Lock].

The operation lock is activated when the user is logged off automatically or manually.

If a key on the controller is pressed when the operation is locked, a password prompt is displayed. Enter the password for the required user.

## 10.7 Configuring the Extra Functions

Besides heating, many furnaces support additional functions such as exhaust-air flaps, fans, solenoid valves, optical and acoustic signal (see, as necessary, addition instructions for the extra functions). For this purpose, each segment offers an opportunity to enter values. How many extra functions are available depends on the furnace design.

With this controller, in the basic configuration, optionally, up to 2, with additional modules, up to 6 extra functions, depending on the program, can be switched on or off in the segments.











### Extra Functions Are for Example

- Activating a fresh-air fan

- Activating an exhaust air flap
- Activating a signal lamp

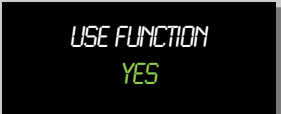

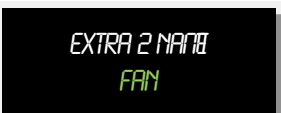

If you want to deactivate or rename individual functions, perform the following steps.



## 10.8 Deactivate or Rename Extra Functions

Disable or rename extra functions			ADMIN
Steps	Operation	Display	Comments
Select the menu level and turn to select the function [SETTINGS]			
Select the menu [EXTRAFUNCTIONS]			This menu item is displayed only if extra functions are actually available.
Select extra function			
Switch extra function on or off			
Change the name of the extra function			Warning! Names can be entered only with Latin letters.
Saving changes: Press the “Back” icon and select Save with the jog dial and then confirm or press and hold the jog dial (max. 3 seconds)			If you do not want to save the program, select [NO].

### 10.8.1 Manually Operating Extra Functions During a Running Heating Program

The following steps must be performed if you want extra functions to be manually switched on during a running heating program.

Using extra functions during a current heating program			OPERATOR
Steps	Operation	Display	Comments
Turn the jog dial while the program is running.			A heating program must have been started.
Turn and press to select and confirm the menu [EXTRAFUNCTION SELECT]			Entry is possible only if extra functions are actually available.

Using extra functions during a current heating program			 OPERATOR
Steps	Operation	Display	Comments
Turn and press to select the extra function			There are 3 options for the extra functions [AUTO], [OFF] and [ON]
	<p>The extra function has now been changed manually. There are 3 statuses available for extra functions</p> <p><b>AUTO</b> The extra function is controlled only by the extra functions defined in the heating program</p> <p><b>OFF</b> The extra function is switched off regardless of the heating program</p> <p><b>ON</b> The extra function is switched on regardless of the heating program</p>		







### Caution

Please check what the effects of a manual setting and resetting of an extra function will have on your charge before you do it. Weigh the advantage and the damage carefully before manually intervening.

## 10.8.2 Manually Operating Extra Functions According a Heating Program

The following steps must be performed if you do not want extra functions to be manually operated during a running heating program.

Operate extra functions when the heating program is not running			 OPERATOR
Steps	Operation	Display	Comments
From the main menu press the "Menu" symbol and select and confirm the menu [SELECT EXTRAFUNCTION] by turning and pressing			
Select extrafunction by turning and pressing.			There are 3 selections available for the extra functions [AUTO], [OFF] and [ON]
	<p>The extra function was only adapted manually. There are 3 statuses available for extra functions</p> <p><b>AUTO</b> The extra function is only controlled by the extra functions stored in the heating program</p> <p><b>OFF</b> The extra function is deactivated independent of the heating program</p> <p><b>ON</b> The extra function is activated independent of the heating program</p>		



Operate extra functions when the heating program is not running			 OPERATOR
Steps	Operation	Display	Comments
Reset extra functions	The reset of manually set extra functions is achieved either via the setting [AUTO] or [OFF]. In addition, manually set extra functions are reset at: <ul style="list-style-type: none"> <li>• Program Start</li> <li>• Segment change</li> <li>• Program end</li> </ul>		



**Caution**  
 Please check what the effects of a manual setting and resetting of an extra function will have on your charge before you do it. Weigh the advantage and the damage carefully before manually intervening.

## 10.9 Alarm Functions

### 10.9.1 Alarms (1 and 2)

This controller has 2 freely configurable alarms. An alarm triggers in a certain situation a reaction. An alarm can be flexibly adapted.

#### Parameters of the alarms:

Parameters	
<b>[SOURCE]</b>	<i>Cause for the alarm:</i>
	[BAND]: A tolerance band is exceeded or undercut. Evaluation is relative to the current setpoint.
	[MAX]: A temperature limit is exceeded. The evaluation relates to the absolute actual temperature.
	[MIN]: A temperature limit is undercut. The evaluation relates to the absolute actual temperature.
	[PROGRAM END]: The end of the program is reached.
	[A1]/[A2]: These two signal sources are linked with inputs in the module configuration. Only Nabertherm can make this link.
	[A1 inverted]/[A2 inverted]: These two signal sources are linked with inputs in the module configuration and are then inverted. Only Nabertherm can make this link.
<b>[RANGE]</b>	<i>Range in which monitoring is to take place</i>
	[DWELL TIME]: A dwell time has the same start and target temperature.
	[RAMP]: The start and target temperature differ in a ramp.
	[ALWAYS]: For dwell times and ramps, also during the complete program

Parameters	
<b>[LIMITS]</b>	<i>Depending on the source, additional limits values are queried</i>
	[LIMIT MIN]: With source = [BAND]: Lower limit relative to the setpoint. [0] disables monitoring. With source = Min/Max: Absolute lower limit temperature
	[LIMIT MAX]: With source = [BAND]: Upper limit relative to the setpoint. [0] disables monitoring. With source = Min/Max: Absolute upper limit temperature
<b>[DELAY]</b>	<i>Time that the alarm is to be delayed in seconds</i>
<b>[TYPE]</b>	<i>Definition whether the alarm reaction has to be acknowledged before it is reset. It is also defined here whether a warning is to be output.</i>
	[TRANSIENT]. If the alarm is no longer present, the reaction is automatically reset. No warning is displayed.
	[TRANSIENT+REPORT]: If the alarm is no longer present, the reaction is automatically reset and must be acknowledged by the operator. A warning is displayed.
	[SAVE+REPORT]: If the alarm is no longer present, the reaction is not automatically reset and must be acknowledged by the operator. A warning is displayed.
<b>[REACTION]</b>	<i>Reaction to the alarm. If the alarm condition is fulfilled, the following reactions are possible:</i>
	[RELAY ONLY] A relay is set. This relay must be configured in module configuration.
	[ACOUSTIC ALARM]: An acoustic alarm is output. The acoustic alarm has additional parameters.
	[PROGRAM INTERRUPT]: The current program is interrupted.
	[HOLD]: The current program is held.
	[HOLD-HEATING OFF]: The current program is stopped and the heating is switched off. The safety relay is also deenergized.

Alarms can be configured as follows:

Configuring the Alarms			ADMIN
Steps	Operation	Display	Comments
Select the menu level and, by turning, select the function [SETTINGS]		SETTINGS	
Select the [ALARM FUNCTION] menu		ALARMFUNCTION	
Select Alarm 1 or 2		ALARM 1	
Select [SOURCE] and set the mode you want		SOURCE BAND	
Select [RANGE] and the range you want		RANGE DWEEL TIMES	
Select [LIMIT MAX] and enter the value you want		LIMIT MAX 2 °C	The visibility of the parameter depends on the source selected
Select [LIMIT MIN] and enter the value you want		LIMIT MIN -2 °C	The visibility of the parameter depends on the source selected
Select [DELAY] and enter the value you want		DELAY 20 SEC	Do not set the time too short so that swings in the process do not cause false alarms.
Select [TYPE] and enter the value you want		TYPE STORE+REPORT	
Select [REACTION] and enter the value you want		REACTION HOLD	

### Validity of the Band Alarm and the Min/Max Analysis:

Below you can see a table showing which thermocouples are monitored by a band alarm.

Furnace has 1 zone	The control thermocouple is monitored
Furnace has 1 zone and active charge control	Charge thermocouple is monitored
Furnace has several zones	Master control thermocouple is monitored

Furnace has several zones and active charge control	Charge thermocouple is monitored
Segment with controlled cooling and separate cooling thermocouple	When cooling is enabled, the separate cooling thermocouple is monitored
Segment with controlled cooling without separate cooling thermocouple	When cooling is enabled, the master control thermocouple is monitored

An optional documentation thermocouple is not included.











## 10.9.2 Acoustic Alarm



The acoustic alarm is one of the possible reactions in alarm 1 or 2 of the alarm configuration. The parameters of the acoustic alarm allow the operators to set certain additional properties. Regardless of the configuration of alarm 1 or 2, the output where the acoustic alarm is connected can be output constantly, at intervals, or with time limits.

The acoustic alarm is acknowledged by acknowledging the error message (press the jog dial twice).

Parameters	
[CONSTANT]	In case of alarm, a continuous alarm signal is generated.
[LIMITED]	The alarm signal is interrupted after a preset time and, then, remains turned off.
[INTERVAL]	The alarm signal is turned on for a preset time and then turned off for this preset time. This procedure repeats.

The acoustic alarm can be set as follows:

Setting the accoustic alarm			 ADMIN
Steps	Operation	Display	Comments
Select the menu level and, by turning, select the function [SETTINGS]	 		
Select the [ALARM FUNCTION] menu			
Select [ACOUSTIC ALARM]			
Select [MODE] and set the mode you want			
Set the duration			The effect of this duration depends on the mode selected (see above)

Setting the acoustic alarm			 ADMIN
Steps	Operation	Display	Comments
The changes need not be saved.			Press the "Back" symbol to return to the overview

### 10.9.3 Gradient monitoring

Gradient monitoring monitors the rate at which a furnace heats up. If the furnace heats up faster than set in the limit value (gradient), the program is interrupted.

What is decisive for a reliable analysis of the gradients is the time interval in which the gradient is repeatedly recalculated (sample interval). If it is too short, the gradient alarm is sensitive to fluctuations of the control or the furnace and probably will be triggered too soon. If the sampling interval selected is too long this may also have an impact on the charge or the furnace. This is why the right sampling interval must be calculated by trial runs.

In addition to the sampling interval, a delay of the alarm can be activated. For example, a delay of "3" means that only after 3 measurement cycles have been recognized as having excessive gradients does a reaction take place.









In order to avoid faulty measurements in the lower temperature range, a lower limit temperature can be selected for the analysis.









In the case of multi-zone furnaces and furnaces with charge control, always only the master zone (guide zone) is analyzed.

After a gradient alarm, the first sample interval that does not return a gradient exceedance restarts the heating program. The furnace runs again.

The warning for the gradient alarm can be deleted by switching the controller off and on again.

The following steps must be performed to set the gradient monitoring:

Setting the gradient monitoring			 ADMIN
Steps	Operation	Display	Comments
Select the menu level and, by turning, select the function [SETTINGS]			
Select the [ALARM FUNCTION] menu			
Select the [GRADIENT MONITORING] menu			
Turning the monitoring on or off			

Setting the gradient monitoring			ADMIN
Steps	Operation	Display	Comments
Set the minimum temperature for monitoring			
Set the permissible gradients (temperature rise)			
Sampling interval (length of the measurement cycle)			
Set the delay of the alarm			



#### Caution

This function contributes to protecting the charge and the furnace. A use for the avoidance of dangerous conditions is not permissible.

### 10.9.4 Examples of Alarm Configuration

Below you will find some helpful points for parametrizing frequently occurring alarms. These examples are only for the purpose of illustration. The parameters may have to be adapted to the application.

When you set the alarms, please remember to log-on as the [ADMIN] user.

#### Example: External error

An external error, e.g. a temperature switch signals an over-temperature by closing a contact. This should result in a program interrupt.

Function	Source	Range	Limits	Delay	Type <sup>1</sup>	Reaction
External fault	A1	Always	-	2s	Save + Report	[PROGRAM INTERRUPT]:

Explanation: The source of the alarm is an input that was linked to [A1], which is evaluated [always], that is, during ramps and hold times. After a delay of [2 seconds], a reaction that must be acknowledged S = [Save], namely [Program interrupt], is triggered with a clear text message M = [Report].

The output configuration of an acoustic alarm must be set at the factory.

#### Examples: Cooling water monitoring

When the cooling water flow of a furnace is monitored. After a flow switch is triggered, the program will be held up and the heating turned off. An acoustic alarm will signal an error.

Function	Source	Range	Limits	Delay	Type <sup>1</sup>	Reaction
Cooling water monitoring	A1	Always	-	2s	Save + Report	[HOLD-HEATING OFF]
Acoustic alarm	A1	Always	-	2s	Save + Report	[ACOUSTIC ALARM]

### Examples: Monitoring of an external vacuuming

For certain processes it is important that during the heating program an external venting is switched on. This should be monitored by the controller and the program interrupted, if necessary, if the venting has not been switched on. In addition, an acoustic alarm should signal the error.

Function	Source	Range	Limits	Delay	Type <sup>1</sup>	Reaction
External extraction	A1	Always	-	120s	Save + Report	[PROGRAM INTERRUPT]:
Acoustic alarm	A1	Always	-	120s	Save + Report	[ACOUSTIC ALARM]

Explanation: The source of the alarm is an input that was linked to [A1], which is evaluated [always], that is, during ramps and hold times. After a delay of [120 seconds], a reaction that must be acknowledged S = [Save], namely [Program interrupt], is triggered with a clear text message M = [Report].

The output configuration of an acoustic alarm must be set at the factory.

### Example: Relative Over-Temperature Monitoring

A dwell time should be monitored. Here, the program setpoint should not be exceeded by more than 5 °C.

Function	Source	Range	Limits	Delay	Type <sup>1</sup>	Reaction
Relative Temperature Monitoring	Band	Hold time	Max = 5° Min = -3000°	60s	Transient + Report	[HOLD-HEATING OFF]

Explanation: The source of the alarm is band monitoring [Band], which is [always] evaluated, that is, during ramps and hold times. After a delay of [60 seconds], a reaction that must be acknowledged [Transient], namely [Program interrupt], is triggered with a clear text message M = [Report].

## 10.10 Network Failure Behavior Settings

In case of a power outage, no heater power remains. Hence, any power outage has an impact on the product in the furnace.

The behavior of the controller during a grid power outage has been preset at Nabertherm. But you can always change this behavior to suit your own needs.

There are 4 modes available:

Mode	Parameter
<b>Mode 1</b>	[CANCEL]: If there is a power outage, the program is canceled.

Mode	Parameter
<b>Mode 2</b>	[DELTA T] When the power returns, the program continues if the furnace has not cooled too much [ $<50\text{ °C}/90\text{ °F}$ ]. Otherwise the program is canceled. The program is always canceled below a limit temperature [T min = $80\text{ °C}/144\text{ °F}$ ].
<b>Mode 3</b>	[TIME] (pre-selection) When the power returns, the program continues if the power was not out for longer than the set time [max. power outage time 2 minutes]. Otherwise the program is canceled.
<b>Mode 4</b>	[CONTINUE] When the power returns, the program always continues.



### Caution

After a power outage the program, i.e. the remaining run time of the dwell time, is continued at the same rate.

Power outages  $< 5\text{ s}$  are always continued.

The behavior after power outage can be set as follows:

Network Failure Settings			ADMIN
Steps	Operation	Display	Comments
Select the menu level and, by turning, select the function [SETTINGS]			
Select the [POWER OUTAGE] menu			
If necessary, set the mode of the behavior after power outage as described above			
The changes need not be saved.			Press the [Back] symbol to return to the overview

## 10.11 System Settings

### 10.11.1 Setting Date and Time

This controller needs a real-time clock for saving process data and the setting of a starting time. This is buffered with a battery in the operating housing.



There is no automatic reset from daily saving to standard time. The time must be reset manually.

The time may only be reset if no program is active to avoid irregularities during the recording of process data.

The following steps must be performed to set the time and the date:

Set date and time			 SUPERVISOR
Steps	Operation	Display	Comments
Select the menu level and turn to select the function [SETTINGS]	 		
Select the menu [SYSTEM] and then [DATE TIME]			
Set the time and date using the jog dial			
Saving changes: Press the “Back” icon and select Save with the jog dial and confirm or press and hold the jog dial (max. 3 seconds)	 		If you do not want to save the program, select [NO].



**Caution**

The operating life of the battery is approx. 3 years. When the battery is replaced the time setting is lost. Battery type: see "Technical Data".





**10.11.2 Setting the Date and Time Formats**







The date can be entered/outputted in two formats:

- MM-DD-YYYY - Example: 11/28/2014
- MM-DD-YYYY - Example: 1128.2014

The time can be entered either in a 12-hour or a 24-hour format.

The following steps must be performed to set these formats:

Setting the date and time format (12h/24h)			 ADMIN
Steps	Operation	Display	Comments
Select the menu level and turn to select the function [SETTINGS]	 		



Setting the date and time format (12h/24h)			ADMIN
Steps	Operation	Display	Comments
Select the menu [SYSTEM] and then [DATE FORMAT] or [TIME FORMAT]			
Set and confirm the settings using the jog dial			
Changes do not have to be saved			Press the [Back] icon to go back to the overview

### 10.11.3 Language Setting







The available languages can be selected on the display/screen. When you are making your selection, a list of the available languages is displayed.



#### Note - Quick Language Selection

If you want to quickly change the language, please open the info menu  and press the  key for several seconds until the language selection is displayed. Then select the appropriate language.

You can set the language without using the quick selection by carrying out the following steps:

Set language			OPERATOR
Steps	Operation	Display	Comments
Select the menu level and turn to select the function [SETTINGS]			
Select the menu [SYSTEM] and then [LANGUAGE]			
Set and confirm the language using the jog dial			
Changes do not have to be saved			Press the [Back] icon to go back to the overview







### 10.11.4 Change Temperature Unit (°C/°F)

This controller can display two temperature units:

- °C (Centigrade, default setting)
- °F (Fahrenheit)

After a reset, all the inputs and outputs of temperature values are displayed in the corresponding unit, and/or entered. Only the inputs in the service area are not reset.

The following steps must be performed to change the temperature unit:

Change the temperature unit (°C/°F)			ADMIN
Steps	Operation	Display	Comments
Select the menu level and turn to select the function [SETTINGS]			
Select the menu [SYSTEM] and then [TEMPERATURE UNIT]			
Set and confirm the temperature unit using the jog dial			
Changes do not have to be saved			Press the [Back] icon to go back to the overview

### 10.11.5 Setting the Interface

There are 2 ways to record process data:

Data recording using the USB interface	
	Onto a USB stick via the USB interface
Interface	USB 2.0
Memory capacity	up to 16 GB
File system	Fat32

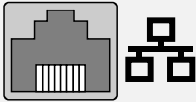
Data recording via Ethernet interface	
	Recording with the VCD process data software via an optional Ethernet interface. Files cannot be stored in a network folder or on an external hard drive.

The Ethernet interface, in contrast to the USB interface, requires additional settings to be connected to a network.

These are:

Required settings if an Ethernet interface is used	Explanation
<b>DHCP</b>	Mode for address assignment
<b>IP Address</b>	Address of the Ethernet interface. Network subscribers may not use the same IP address.
<b>Subnet Mask</b>	Mask for describing the address space
<b>DNS Server</b>	Server address for name resolution
<b>Host Name</b>	Default setting: [serial number] 8 characters must be entered. Entry must be in Latin characters.
<b>Communication Port</b>	Port 2905











### Caution

Consult your network administrator about the settings.

The use of this interface is not possible in connection with IPv6. Connect the controller to an existing network without knowledge about this network can lead to malfunctions in the network.

The following steps must be performed to set these parameters:

Setting the Data Interface (USB/Ethernet)			ADMIN
Steps	Operation	Display	Comments
Select the menu level and, by turning, select the function [SETTINGS]			
Select the [SYSTEM] menu and, then, [INTERFACES]			
Select [DHCP] and the address assignment mode			DHCP = Yes: The address of the controller is provided via a customer DHCP DHCP = No: Address is entered manually
Select [IP ADDRESS] and enter the IP address		 (Example)	If you are uncertain, ask your IT department about a network integration.
Select [SUBNET MASK] and enter		 (Example)	If you are uncertain, ask your IT department about a network integration.

Setting the Data Interface (USB/Ethernet)			 ADMIN
Steps	Operation	Display	Comments
Select [DNS SERVER] and enter		 (Example)	If you are uncertain, ask your IT department about a network integration.
Select [GATEWAY] and enter		 (Example)	If you are uncertain, ask your IT department about a network integration.
Enter [HOST NAME]		 (Example)	If you are uncertain, ask your IT department about the Host Name. The number of entered characters must always be 8. This name is also used for the data fold on a USB stick.  Warning! A name can only be entered in Latin letters.
The changes need not be saved.			Press the [Back] symbol to return to the overview

### Sample Configuration with DHCP Server (only available with router or in larger networks)

<b>DHCP</b>	Yes (with a permanently allocated IP address)
<b>IP Address</b>	-
<b>Subnet Mask</b>	-
<b>DNS Server</b>	-
<b>Host Name</b>	Default: [serial number]  The number of entered characters must always be 8. The entry can only be made in Latin letters.



#### Note

Configure the DHCP server so that it always allocates the same IP addresses to the controllers. If a controller changes its IP address, it can no longer be found by the VCD software.

### Sample Configuration with Fixed IP Address (for example, in small networks)

<b>DHCP</b>	No
<b>IP Address</b>	192.168.4.1 (PC with VCD software) 192.168.4.70 (Furnace 1) 192.168.4.71 (Furnace 2) 192.168.4.72 (Furnace 3) ...
<b>Subnet Mask</b>	255,255,255.0

<b>DHCP</b>	<b>No</b>
<b>DNS Server</b>	0.0.0.0 (no DNS server) or 192.168.0.1 (example)
<b>Host Name</b>	Default: [serial number] The name is user defined (Latin letters). The number of entered characters must always be 8. The entry can only be made in Latin letters.

## 10.12 Importing and Exporting Process Data, Programs and Parameters

All the data in this controller can be saved on a USB stick (exported) or loaded (imported).

**The following parameters are not taken into account for a parameter import:**

- Controller type (User: [Service])
- Maximum possible temperature of the furnace (User: [Service])
- Information from the info-menu
- Passwords of the users
- Furnace power (User: [Service])
- Various monitoring parameters (over-temperature)

### Saved data after a complete export on the USB stick

<b>Programs</b>	File: [HOSTNAME]\PROGRAMS\prog.01.xml
<b>Control Parameters</b>	File: [HOSTNAME]\SETTINGS\parameter.pid.xml
<b>Settings</b>	File: [HOSTNAME]\SETTINGS\parameter.config.xml
<b>Malfunctions</b>	File: [HOSTNAME]\ERRORLOG\dump.error.xml
<b>Process Data</b>	File: [HOSTNAME]\ARCHIVE\20140705_14050102_0001.csv
<b>Import Folder</b>	Folder \IMPORT\...

The control parameters, settings and programs can also be individually exported or imported. When a complete export is performed all the files are saved on the USB stick.

The use of this function can be best explained by several examples:

- **Example 1 - Import of Programs:**  
Three identical furnaces should always be operated with the same program. The program is prepared using the controller, exported to a USB stick and re-imported to the other controllers. All controllers receive the same programs. Before importing, the exported data must always be copied to the IMPORT folder.
- Make sure that the prepared programs do not include any temperatures higher than the maximum temperature of the furnace. These temperatures will not be accepted. The maximum number of controller segments and programs must not be exceeded. A message shows whether the program was imported successfully.
- **Example 2 - Import of PID Parameters:**  
The control parameters of a furnace are optimized based on a temperature uniformity

measurement. The control paramets can then be transferred to other furnaces or simply archived. Before importing, the exported data must always be copied to the import folder.

- **Example 3 - Forwarding the data by email to Nabertherm Service:**  
In case of a service incident, Nabertherm Service requests that you save all the data to a USB stick. Then simply forward the data by email.



**Note**

If the controller breaks down, all the settings that the operator has entered are lost. The complete export of the data to a USB stick permit this data to be backed up. It can then be simply imported to a new, equivalent controller.



**Caution**

Files that you want to import must be saved on the USB stick in the folder "\\IMPORT\". Do **NOT** create this folder in an exported folder of a controller. The "Import" folder must be on the top level.

When you perform an import, all the files in this folder are imported.

NO subfolders may be used!



**Note**

If you want to import files into the controller, the import process can fail if these files were previously changed. The import files must not be changed. If the import is not successful, make the necessary changers directly in the controller and export the files again.







**Caution**







When you insert the USB stick, a symbol is displayed in the lower right of the display. As long as the control unit is writing or reading data, the symbol blinks. These procedure can last as long as 45 seconds. Wait until this symbol stops blinking before you pull out the USB stick!

For technical reasons, all the archive files on the controller are always synchronized. That is why this time can vary depending on the sizes of the files.

**IMPORANT: Do not connect here any PC, external harddrive or any other USB host/controller - You may damage both devices.**

The following steps must be performed to export or import the data onto a USB stick:











Exporting or Importing Data to or from a USB Stick			 OPERATOR
Steps	Operation	Display	Comments
Insert the USB stick into the control unit			Always wait until the symbol for the USB stick has stopped blinking.
Select the menu level and, by turning, select the function [SETTINGS]			

Exporting or Importing Data to or from a USB Stick			 OPERATOR
Steps	Operation	Display	Comments
Select the [IMPORT/EXPORT] menu			The IMPORT is only allowed to the [ADMIN] user
			 ADMIN
Select the data you want to import or export			
Wait until the symbol for the USB stick has stopped blinking.			Pull out the USB stick.
After an import of parameters, turn off the controller, wait 10 second and turn the controller on again	See sections: <ul style="list-style-type: none"> <li>• Turning off the Controller/Furnace</li> <li>• Turning on the Controller/Furnace</li> </ul>		After the import of PID parameters and programs, a reboot is not necessary.



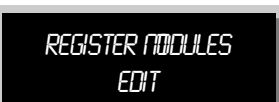

## 10.13 Registering Modules

The registration of the modules must be performed for each first startup or the replacement of a module, for controllers with more than one controller module. It allows the allocation of the module address to the controller module.

Perform the following steps to register a module:

Registering a Module			 ADMIN
Steps	Operation	Display	Comments
Select the menu level and, by turning, select the function [SETTINGS]			
Select the [SERVICE] menu			
Select the [REGISTER MODULES] menu			
Select the [REGISTER MODULES/EDIT] menu			
Select [ADD MODULE] menu			



Registering a Module			ADMIN
Steps	Operation	Display	Comments
Then press the small button on the top side of the control module. This is accessible through a small hole below the LED on the control module in the switchgear. Use a paper clip (if necessary, break off the thick end)			
After successfully registering the module, you must assign an address to the module using the jog dial			A safety prompt must then be confirmed
The changes need not be saved. Repeat this procedure until all the modules are registered			Press the [Back] symbol to return to the overview

The [BUS RESET] is only for service purposes.

The [REGISTER MODULES] is only for the display of service information.

## 10.14 Activating an Air Recirculator

This controller is able to activate an air recirculator. A recirculator can be destroyed by heat in case of a standstill. That is why the control of the air recirculator is controlled as a function of the furnace temperature.

As soon as a program was started at the controller, the air recirculation motor starts. They continue to operate until the program is completed or interrupted and the furnace temperature has fallen below a previously set value (e.g. 80 °C/176 °F).

This temperature dependent behavior always relates to the temperature of the master zone and during active charge control onto the thermocouple of the charge control.

The configuration of this function can only be performed at the factory and with the [Service] user.

In connect with a connected and door contact switch, set at the factory, this air recirculation function is extended again:





If the furnace is opened, the air recirculation motor is switched off. After 2 minutes, the air recirculation motor is automatically restarted, even if the door ist still open, to prevent a destruction of the air recirculator.

This function can also be similarly used for a door locking mechanism.

## 11 Information Menu

The information menu supports the rapid display of selected controller information.

You can access the information menu by pressing the information key in the overview:

Information Menu			 OPERATOR
Steps	Operation	Display	Comments
Select information menu from the overview			
Select subfunction			

The following information can be called in sequence:

### Calling up data via the information menu

#### Controller output

This menu provides an important tool to optimize the control parameters. When the controller/zone is selected, the P/I and D parts and the actual value, setpoint and output of the controller are displayed. The values are displayed only during a program.

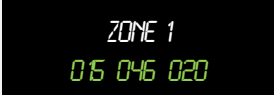

(Example)

With this display, the effect of a changed parameter can be checked immediately.

The values for controlled cooling are displayed via the control zone. If controlled cooling is enabled, the output of the controlled cooling is shown as negative values.

<b>Controller</b>	Type and version of the controller
<b>Serial number</b>	Unique production number of the controller
<b>Current program</b>	Program that is currently running
<b>Current setpoint</b>	Setpoint of the current program
<b>Current run time</b>	Expired time of the current program
<b>Run time remain</b>	Remaining time of the current program
<b>Last start</b>	Start time of the last heating program
<b>Error</b>	Current error
<b>Last error</b>	The last error that occurred
<b>Max oven temp</b>	The maximum temperature for which the furnace is designed

Calling up data via the information menu	
<b>Statistics</b> Please also observe the notes below this table	Last consumption in [kWh] Consumption in [kWh] Operating hours, e.g. [1D 17 h 46min] Number of starts [17] Number of starts > 200 °C [17] Number of starts > 1200 °C [17] Achieved temperature
<b>Module status</b>	Display of current input and output statuses of a control module. [DA1/2]          Digital outputs 1 and 2 [AA1/AA2]      Analog outputs 1 and 2
<b>File name</b>	Name of the process data file that is currently being recorded or was recorded. Example: [20140625_140400_0001].csv
<b>Display parameters</b>	Reserved for a later version
<b>Service export</b>	If you confirm this menu entry with the button, all exportable information is saved on a plugged in USB flash drive. Use this information, for example, within the scope of a service inquiry from Nabertherm Service. This function is also available via the function "Import/Export" and is provided here simply because of its easier availability.
<b>MAX TEMP LAST PROGRAM</b>	Maximum furnace temperature of the last program (see also "Statistics")



**Caution**  
 In order to be able to help quickly in case of an error, the values of the information menu are very helpful for localizing the error. In case of a malfunction, please fill out the printed check list in the "**Check List Controller Complaint**" section and place it at our disposal.





**Note**  
 The energy counter (kWh counter) calculates its value from the power output and a specified furnace power. If a regulator with non-linear behavior is used to control the heating (e.g. a phase section), this can lead to considerable deviations from the actual value when the energy consumption is being calculated.

## 12 Eurotherm 2132i Over-Temperature Limiter (Option)



The Eurotherm 2132i over-temperature limiter monitors the furnace chamber temperature using an independent measurement circuit. If the furnace chamber temperature rises above the configured value (generally  $T_{max} + 30\text{ }^{\circ}\text{C}/86\text{ }^{\circ}\text{F}$ ) the heater is turned off by a safety fuse to protect the furnace – "FSH" alarm flashes on the over-temperature limiter.

If the temperature falls back below the configured value, it must be acknowledge for operation to resume. To do this, the keys  and  must be pressed simultaneously on the over-temperature limiter in order to enable the heater again.

A temperature selection monitor (option for melting furnaces), unlike the temperature selection limiter, can turn the heating back on after it exceeds the limit. No acknowledgment is necessary.



### Note

The overtemperature limiter and overtemperature selection monitor (optional) must be checked for proper functioning at regular intervals!



### Note

See Eurotherm 2132i instructions

## 13 Malfunctions

### 13.1 Error Messages of the Controller

ID+ Sub-ID	Text	Logic	Remedy
<b>Communication error</b>			
01-01	Bus zone	Communication connection to a control module disrupted	Check that the control module is firmly attached. LEDs on the control modules red? Check the cable between the operating unit and the control module. Plug of the connection cable not plugged correctly into the operating unit
01-02	Bus communication module	Communication connection to the communication module (Ethernet/USB) disrupted	Check that the communication module is firmly attached. Check the cable between the operating unit and the communication module.
<b>Sensor error</b>			
02-01	TC open		Check thermocouple, thermocouple terminals and cable. Check contacts of the thermocouple cable in plug X1 on the control module (contacts 1+2).
02-02	Outside TC measurement range		Check set thermocouple type. Check poles of thermocouple connection.

ID+ Sub-ID	Text	Logic	Remedy
02-03	Compare point error		Control module defective
02-04	Compare point too hot		Temperature in the switchgear too high (approx. 70 °C) Control module defective
02-05	Compare point too cold		Temperature in the switchgear too low (approx. -10 °C)
02-06	Encoder separated	Error at the 4-20 mA input of the controller (<2 mA)	Check 4-20 mA sensor. Check the connection cable to the sensor.
02-07	Sensor element defective	PT100 or PT1000 sensor defective	Check PT sensor. Check connection cable to the sensor (cable break/short circuit).
<b>System error</b>			
03-01	System memory		Error after firmware updates <sup>1)</sup> Defective operating unit <sup>1)</sup>
03-02	ADC error	Communication between AD converter and controller disrupted	Replace control module. <sup>1)</sup>
03-03	File system defective	Communication between display and memory chip disrupted	Replace operating unit.
03-04	System monitoring	Program execution on the operating unit defective (Watchdog)	Replace operating unit. USB flash drive removed too soon or defective Switch controller off and on again.
03-05	Zone system monitoring	Program execution on a control module defective (Watchdog)	Replace control module. <sup>1)</sup> Switch controller off and on. <sup>1)</sup>
03-06	Self test error		Contact Nabertherm Service. <sup>1)</sup>
<b>Monitoring</b>			
04-01	No heater power	No temperature increase in the ramps when heating output <> 100 % for 12 minutes and when the temperature setpoint is higher than the current furnace temperature	Acknowledge the error (if necessary disconnect from the power supply) and check safety contactor, door switch, heating controls and controller. Lower D value of the control parameters.

ID+ Sub-ID	Text	Logic	Remedy
04-02	Excess temperature	The temperature of the control zone exceeds the max. program setpoint or the maximum furnace temperature by 50 Kelvin (from 200 °C). The equation for the switch off threshold is: Maximum program setpoint + zone offset of the master zone + charge control offset [Max] (if charge control active) + excess temperature switch-off threshold (P0268, e.g. 50 K)	Check solid state relay. Check thermocouple. Check controller.
		A program was started at a furnace temperature higher than the maximum setpoint in the program	Do not start the program until the furnace temperature is lower. If this is not possible, insert a hold time as a start segment and then a ramp with the desired temperature (STEP=0 minutes duration for both segments). Example: 700 °C -> 700 °C, Time: 00:00 700 °C -> 300 °C, Time: 00:00 The normal program begins here. From Version 1.14, the actual temperature at the start is also considered.
04-03	Power outage	The set limit for restarting the furnace was exceeded	If possible, use an uninterruptible power supply.
		The furnace was switched off at the main switch during the program	Stop the program on the controller before you switch off the main switch.
04-04	Alarm	A configured alarm was triggered	
04-05	Autotune failed	The determined values are implausible	Do not carry out self-optimization at the lower temperature range of the furnace working range.
	Battery weak	Time is not shown correctly. A power failure may not have been handled properly	Export all parameters to a USB flash drive. Replace the battery (see “Specifications”).
<b>Other malfunctions</b>			
05-00	General malfunction	Malfunction in the control module or Ethernet module	Contact Nabertherm Service. Provide the service export.

<sup>1)</sup> The error can only be acknowledged by switching off the controller.



Error messages can be reset by pressing twice the jog dial . If there is another error message, contact Nabertherm Service. Recirculation motors (if included) also remain switched on in case of an error until the temperature falls below the set cut-off temperature.

## 13.2 Warnings of the Controller

Warnings are not displayed in the error archive. They are only displayed on the display and in the file of the parameter export. Warning do not generally lead to a program crash.

No.	Text	Logic	Remedy
00	Gradient monitoring	The limit value of configured gradient monitoring was exceeded	For troubleshooting, refer to “Gradient Monitoring”. Gradient set too low
01	No control param	No “P” value was entered for the PID parameters	Enter at least one “P” value in the control parameters. It must not be “0”.
02	Charge elem defective	No charge thermocouple was determined with the current program and activated charge control	Plug in a charge thermocouple. Disable charge control in the program. Check the charge thermocouple and its cable for damage.
03	Cooling thermocouple defective	The cooling thermocouple is not plugged in or is defective	Plug in a cooling thermocouple. Check the cooling thermocouple and its cable for damage. If there is a malfunction in the cooling thermocouple during active controlled cooling, the system switches over to the thermocouple of the master zone.
04	Documentation thermocouple defective	Either no documentation thermocouple or a defective one was determined	Plug in a documentation thermocouple. Check the documentation thermocouple and its cable for damage.
05	Power outage	A power outage was detected There was no program interruption	None
06	Alarm 1 - Band	The configured band alarm 1 was triggered	Optimize the control parameters. Alarm set too narrowly
07	Alarm 1 - Min	The configured min. alarm 1 was triggered	Optimize the control parameters. Alarm set too narrowly
08	Alarm 1 - Max	The configured max. alarm 1 was triggered	Optimize the control parameters. Alarm set too narrowly
09	Alarm 2 - Band	The configured band alarm 2 was triggered	Optimize the control parameters. Alarm set too narrowly
10	Alarm 2 - Min	The configured min. alarm 2 was triggered	Optimize the control parameters. Alarm set too narrowly
11	Alarm 2 - Max	The configured max. alarm 2 was triggered	Optimize the control parameters. Alarm set too narrowly
12	Alarm - External	The configured alarm 1 at input 1 was triggered	Check the source of the external alarm.
13	Alarm - External	The configured alarm 1 at input 2 was triggered	Check the source of the external alarm.

No.	Text	Logic	Remedy
14	Alarm - External	The configured alarm 2 at input 1 was triggered	Check the source of the external alarm.
15	Alarm - External	The configured alarm 2 at input 2 was triggered	Check the source of the external alarm.
16	No USB flash drive inserted		When exporting data, insert a USB flash drive in the controller.
17	Import/export of data via the USB flash drive unsuccessful	The file was edited with a PC (text editor) and saved in the wrong format or the USB flash drive was not detected. You want to import data that is not in the import folder on the USB flash drive.	Do not edit XML files with a text editor, only in the controller. Format the USB flash drive (format: FAT32). No quick formatting Use a different USB flash drive (1-16 GB). When importing, all data must be in the import folder on the USB flash drive. The maximum storage capacity for USB flash drives is 16 GB. If you experience problems with your USB flash drive, use a different USB flash drive with maximum 8 GB.
	Programs are rejected during the import of programs	Temperature, time or rate are outside the limit values	Import only programs that are suitable for the furnace. The controllers differ as regards the number of programs and segments and the maximum furnace temperature.
	While programs are being imported, "Error occurred" is displayed	The complete parameter set (at least the configuration files) was not stored in the "Import" folder on the USB flash drive	If you deliberately left out files during import, ignore the message. Otherwise, check the completeness of the import files.
18	"Heating blocked"	This message is displayed if a door switch is connected to the controller and the door is open	Close the door. Check the door switch.

### 13.3 Malfunctions of the Switchgear

Error	Cause	Remedy
<b>Controller does not light up</b>	Controller is switched off	Switch the power switch to "I"
	No power available	Is the power cord plugged into the socket? Check the building fuses. Check the fuse of the controller (if present) and replace it if necessary.
	Check the fuse of the controller (if present) and replace it if necessary.	Switch the power switch on. If the error occurs again, contact Nabertherm Service
<b>Controller displays error</b>	See the separate instructions of the controller	See the separate instructions of the controller



Error	Cause	Remedy
<b>Furnace does not heat</b>	Door / cover is open	Close the door / cover
	The door contact switch is faulty (if present)	Check the door contact switch
	The “wait” or clock icon (product line 400 controllers) lights up	The program is waiting for the programmed start time. Set the wait time to 00:00 or disable it
	Error in entering the program	Check the heating program (see the separate instructions of the controller)
	Heating element defective	Have this checked by Nabertherm Service or a qualified electrician.
<b>Very slow heating of the heating space</b>	The fuse(s) of the connection is/are defective.	Check the fuse(s) of the connection and replace if necessary. Notify Nabertherm service if the new fuse fails again immediately.
<b>The program does not jump to the next segment</b>	In one TIME segment in the program input, the wait time is set to INFINITE (product line 400 controllers). If charge control is activated, the temperature of the charge is higher than the zone temperatures.	Do not set the wait time to INFINITE
	If charge control is activated, the temperature of the charge is higher than the zone temperatures.	The parameter [LOWER BLOCK] must be set to [NO].
<b>The controller module can not be registered on the operating unit</b>	Addressing error (product line 400 controllers)	Perform a bus reset
<b>The controller is not heating in the optimization</b>	No optimization temperature has been set	The temperature to be optimized must be entered (see the separate instructions of the controller)
<b>The temperature rises faster than the controller setting allows</b>	The switch element of the heating unit (semiconductor relay, thyristor or switch contactor) is defective.  Individual defective components inside a furnace cannot be completely ruled out in advance. That is why the controllers and the switchgear units must be equipped with safety facilities. For example, the furnace shuts down the heating unit in response to error message 04 - 02 via an independent contact element.	Have the switch element tested by a qualified electrician and replaced as necessary.

### 13.4 Controller Check List

<b>Customer:</b>	
<b>Furnace model:</b>	
<b>Controller model:</b>	

<b>Controller version (see information menu ):</b>										
<b>Controller serial number</b>										
<b>Furnace serial number</b>										
<b>Error code in the display:</b>										
<b>The following errors are dependent on external influences:</b>	02-05 Ambient temperature too low: < -10 °C (14 °F) 02-04 Ambient temperature too high: > 70 °C (158 °F)									
<b>Detailed error description:</b>										
<b>Export of the service information:</b>	Please export all the data to a USB stick using the function [EXPORT COMPLETELY] Generate a zip file using the ZIP function integrated in Windows (compression) of the exported folder (see the section "Importing and Exporting Data and Parameters") and send them to your contact at Nabertherm Service.									
<b>When does this error occur?</b>	At specific point in the program or at certain times of day:  At specific temperatures:									
<b>How long has the error existed?</b>	<input type="checkbox"/> Error is new <input type="checkbox"/> Error has existed for a long time <input type="checkbox"/> Unknown									
<b>Error frequency</b>	<input type="checkbox"/> Error occurs frequently <input type="checkbox"/> Error occurs regularly <input type="checkbox"/> Error occurs rarely <input type="checkbox"/> Unknown									
<b>Substitute controller:</b>	<table border="1"> <tr> <td>Has a substitute controller already been used?</td> <td><input type="checkbox"/> yes</td> <td><input type="checkbox"/> no</td> </tr> <tr> <td>Did the error continue with the substitute controller?</td> <td><input type="checkbox"/> yes</td> <td><input type="checkbox"/> no</td> </tr> <tr> <td>Checked according to the error search list (see the furnace operating instructions)</td> <td><input type="checkbox"/> yes</td> <td><input type="checkbox"/> no</td> </tr> </table>	Has a substitute controller already been used?	<input type="checkbox"/> yes	<input type="checkbox"/> no	Did the error continue with the substitute controller?	<input type="checkbox"/> yes	<input type="checkbox"/> no	Checked according to the error search list (see the furnace operating instructions)	<input type="checkbox"/> yes	<input type="checkbox"/> no
Has a substitute controller already been used?	<input type="checkbox"/> yes	<input type="checkbox"/> no								
Did the error continue with the substitute controller?	<input type="checkbox"/> yes	<input type="checkbox"/> no								
Checked according to the error search list (see the furnace operating instructions)	<input type="checkbox"/> yes	<input type="checkbox"/> no								

Please enter the following test program so that the furnace heats up at full power:

Program point	Value
Segment 01- Start Temperature	0 °C
Segment 01- Target Temperature	500 °C

Program point	Value
Segment 01- Time	5 minutes
Segment 01- Target Temperature	500 °C

Close door/lid and start the example program

Please check the following items:

- Does the furnace heat (temperature rise)?
- Is the "Heating" symbol displayed?

Please call up the information menu in the heating up phase for further details.

Date: \_\_\_\_\_ Name: \_\_\_\_\_ Signature: \_\_\_\_\_

## 14 Specifications



Furnace data related to electrical power are on the type plate located on the side of the furnace. The type plate of each of the controllers is located on the controller modules in the switchgear.

Controller Series 400-1 (B400/B410, C440/C450, P470/P480)		
<b>Supply voltage:</b>	<b>Controller power adapter:</b> ~100 V – 240 V 50/60 Hz <b>Controller:</b> 12 V DC	The adapter must not be used for other devices.
<b>Power consumption (12 V circuit):</b>	Maximum 70 mA for the operating unit Maximum 235 mA per power unit Maximum 50 mA for the communication module Maximum 50 mA per power unit as charge control	Power consumption with 3 zone modules, 1 charge module, 1 cooling module and 1 communication module: Approx. max. 1110 mA
<b>Sensor input:</b>	TC thermocouple TC 0-10 V TC 4-20 mA PT1000 PT100	Parameterization only by Nabertherm
<b>Thermocouple types:</b>	Type B/C/E/J/K/L/N/R/S/T	Parameterization only by Nabertherm
<b>Digital inputs 1 and 2:</b>	12 V, max. 20 mA	Use potential-free contact
<b>Analog outputs 1 and 2:</b>	Constant 0 – 5 V, 0 – 10 V, maximum 100 mA	Analog output, digitally switched. I <sub>max</sub> approx. 100 mA)
<b>Safety relay:</b>	240 Vac / 3 A with ohmic load, preliminary fuse max. 6.3 A (C-characteristic)	

**Controller Series 400-1 (B400/B410, C440/C450, P470/P480)**

<b>Extra relay</b>	240 Vac / 3 A with ohmic load, preliminary fuse max. 6.3 A (C-characteristic)	The two extra relays of a module must only be supplied with one voltage. Voltages must not be mixed. If this is the case, another module must be used.
<b>Real-time clock:</b>	Yes	
<b>Buzzer:</b>	Connect externally via output	
<b>Battery:</b>	3 V/285 mA Lithium Model: CR2430	When the battery is replaced, dispose of the used one properly. Batteries must not be disposed of with household waste.
<b>Protection type:</b>	Mounted housing: IP40 with closed USB interface cover. Front film: IP protection type of the surrounding housing is not reduced by the film.	
	Control module/power adapter: IP20	
	Furnace/Switchgear	(see furnace/switchgear instructions)
<b>Interface:</b>	USB host integrated (USB flash drive)	No other devices, such as hard disks or printers may be connected. Maximum size: 16 GB.
	Ethernet/USB device	Optionally available as a module 10/100 Mbps (auto-sensing) Automatic correction of crossed lines (cross-over detection)
<b>Measurement accuracy:</b>	+/- 1 °C, 16 bit input card	
<b>Lowest possible rate:</b>	1 °C/h when the rate is entered in the program	
<b>Ambient conditions (according to EN 61010-1):</b>		
<b>Storage temperature:</b>	-20 °C to +75 °C	
<b>Working temperature:</b>	+5 °C to +55 °C	Ensure sufficient air circulation
<b>Relative humidity:</b>	5 - 80% (to 31 °C, 50% at 40 °C)	not condensing
<b>Height</b>	< 2000 m	

## 15 Communication with the Controller

For Series 400 controllers, Nabertherm offers a module for superordinate communication. Data in the controller is accessed via this optional communication module (Ethernet).

<b>Interface</b>	Ethernet, 10/100Mbaud
<b>Protocol</b>	Modbus/TCP
<b>Port</b>	502

The datapoints are listed in the following table:

Datapoint	ParaID	SubID	Modbus address decimal	Read	Write	Min	Max	Comment
Active actual value	2000	0	100	x		-	-	[°C], in tenths of a degree
Temperature of charge zone	2000	1	101	x		-	-	[°C], in tenths of a degree
Temperature of cooling zone	2000	2	102	x		-	-	[°C], in tenths of a degree
Temperature of zone 1	2000	3	103	x		-	-	[°C], in tenths of a degree
Temperature of zone 2	2000	4	104	x		-	-	[°C], in tenths of a degree
Temperature of zone 3	2000	5	105	x		-	-	[°C], in tenths of a degree
Temperature of zone 4	2000	6	106	x		-	-	[°C], in tenths of a degree
Temperature of doc. zone 1	2000	7	107	x		-	-	[°C], in tenths of a degree
Temperature of doc. zone 2	2000	8	108	x		-	-	[°C], in tenths of a degree
Temperature of doc. zone 3	2000	9	109	x		-	-	[°C], in tenths of a degree
Temperature of doc. zone 4	2000	10	110	x		-	-	[°C], in tenths of a degree
Program setpoint	2001	0	111	x		-	-	[°C], in tenths of a degree
Spare	2001	1	112	x		-	-	[°C], in tenths of a degree
Charge setpoint	2001	2	113	x		-	-	[°C], in tenths of a degree
Cooling TC setpoint	2001	3	114	x		-	-	[°C], in tenths of a degree
Setpoint of zone 1	2001	4	115	x		-	-	[°C], in tenths of a degree

Datapoint	ParaID	SubID	Modbus address decimal	Read	Write	Min	Max	Comment
Setpoint of zone 2	2001	5	116	x		-	-	[°C], in tenths of a degree
Setpoint of zone 3	2001	6	117	x		-	-	[°C], in tenths of a degree
Setpoint of zone 4	2001	7	118	x		-	-	[°C], in tenths of a degree
Master power	2002	0	119	x		-	-	[%], in tenths of a percent
Cooling power	2002	1	120	x		-	-	[%], in tenths of a percent
Power zone 1	2002	2	121	x		-	-	[%], in tenths of a percent
Power zone 2	2002	3	122	x		-	-	[%], in tenths of a percent
Power zone 3	2002	4	123	x		-	-	[%], in tenths of a percent
Power zone 4	2002	5	124	x		-	-	[%], in tenths of a percent
Status	411	0	125	x		-	-	0=Off, 1=Wait, 2=Run, 3=Pause, 4=End, 6=Error
Program no.	2003	0	126	x		-	-	-
Segment no.	2004	0	127	x		-	-	-
Run time remain	415	0	128+129	x		-	-	32Bit, 125=Low Word, 126=High Word
Extra relay	414	0	130	x		-	-	Bit array
Alarm 1 Status	860	0	131	x		-	-	-
Alarm 2 Status	860	1	132	x		-	-	-
Warnings	161	0	133+134	x		-	-	Bit array,32Bit, 130=Low Word, 131=High Word, see on the right
Current malfunction	170	0	135	x		-	-	-
Controller type	257	0	136	x		-	-	0=B400, 1=B410, 2=C440, 3=C450, 4=P470, 5=P480
Maximum temperature	600	0	137	x		-	-	[°C]
Serial number	2005	0-9	138-147	x		-	-	ASCII String
Controller command	428	0	148		x	1	3	1=Start, 2=Stop, 3=Pause
Program read command	425	0	149		x	0	50	-

Datapoint	ParaID	SubID	Modbus address decimal	Read	Write	Min	Max	Comment
Segment jump command	426	0	150		x	-40	40	-

**Note**





“Active actual value” is a variable value that represents a controlling temperature value. This also corresponds to the rough temperature value shown on the main overview page of the controller.

Warnings			Current malfunction	
Bit	Value	Description	Display	ID+Sub-ID
0	1	Gradient monitoring	257	01-01
1	2	No control param	258	01-02
2	4	Charge sensor defective	513	02-01
3	8	Cooling sensor defective	514	02-02
4	16	Doc sensor defective	515	02-03
5	32	Restart after power outage	516	02-04
6	64	Alarm 1 band alarm	517	02-05
7	128	Alarm 1 Min	518	02-06
8	256	Alarm 1 Max	519	02-07
9	512	Alarm 2 band alarm	769	03-01
10	1024	Alarm 2 Min	770	03-02
11	2048	Alarm 2 Max	771	03-03
12	4096	Alarm 1 E1	772	03-04
13	8192	Alarm 1 E2	773	03-05
14	16384	Alarm 2 E1	774	03-06
15	32768	Alarm 2 E2	1025	04-01
16	65536	No USB inserted	1026	04-02
17	131072	Import failed	1027	04-03
			1028	04-04
			1029	04-05
			257	01-01

## 15.1 Retrofitting a Communication Module

### 15.2 Scope of Delivery

#### Retrofit kit:

Name	Quantity	Part number	Figure
Communication module for the switchgear (from Version 0.16)	1	520100283 (520100279 for deliveries to replace the defective part)	
Back-wall connector for communications module	1	520900507	
Ethernet cable in the furnace: 1 m 90° angle	1	544300197	
Ethernet socket for feeding the network cable through the wall of the switchgear	1	520900453	

### 15.3 Installing a Communications Module



#### Warning - Danger of Electric Shock!

Only qualified and authorized electricians may work on electric equipment. During maintenance work, furnace and switchgear must be kept voltage-free to prevent accidental start-ups and secure all the movable parts of the furnace. Follow the specifications in the DGUV V3 or corresponding national regulations where the furnace is installed. Wait until the furnace chamber and its attachments have cooled down to room temperature.



 **DANGER**

Control circuits for lighting and service sockets that are needed for maintenance purposes are not switched off by the power supply separation device (main switch) and remain live. The conductors for the wiring are colored (orange)

#### Tool to be made available



Screwdriver

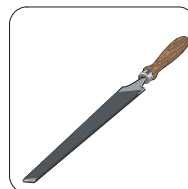





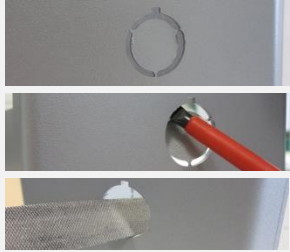

Metal file

Fig. 9: Tools



If you want to connect a furnace/controller that does not yet have a communications module, proceed as follows:

Figure	Description
	<ol style="list-style-type: none"> <li>1. Open the switchgear cover on the furnace.</li> <li>2. At the back of the switchgear, break open the pre-cut hole with a screwdriver. Pay attention to the small groove. It marks the correct hole.</li> </ol>
	<ol style="list-style-type: none"> <li>3. When you have broken the hole open, push the enclosed Ethernet socket through from outside and screw it in place from the back with the nut.</li> </ol>
	<ol style="list-style-type: none"> <li>4. Pull out the plug on the right of the module.</li> <li>5. Insert the enclosed plug here.</li> <li>6. Insert the plug that you pulled out into the new plug on the right.</li> </ol> <p>Note: Ensure correct wiring.</p>
	<ol style="list-style-type: none"> <li>7. Press the communications module on to the rail so that the red clamp also grips the other side of the module over the rail. Fix the module in place by pressing the red clamp towards the module. It must no longer be possible to lift the module from the rail.</li> </ol>
	<ol style="list-style-type: none"> <li>8. Connect the module and the Ethernet socket with the short Ethernet cable (1 m).</li> </ol>
	<ol style="list-style-type: none"> <li>9. Then connect the outside of the Ethernet socket with the PC with the long Ethernet cable (5 m).</li> </ol>

## 16 Type Plate

The type plate of the controller is located for the controllers B400/C440/P470 on the back wall of the operating housing.

For the controllers B410/C450/P480 the type place is near the operating unit, or inside the switchgear.



Fig. 10: Example (type plate)

## 17 Cleaning

The device surface can be cleaned with a mild soapy solution.

The USB interface may only be cleaned with a dry cloth.

The stickers/plates must not be cleaned with abrasive cleansers.

## 18 Maintenance and Spare Times

As shown in the section "Construction of the Controller", the controller consists of several components. The controller modules are always installed in the interior of the switchgear cabinet or the furnace housing. The control unit can be installed in a switchgear cabinet or in the furnace housing. Moreover, there are furnace models whose control unit is attached to the furnace housing so that it can be taken off. The ambient conditions are described in the section "Technical Data".

You must prevent conductive dirt and dust from entering the switchgear cabinet or the furnace housing.

To minimize the coupling of malfunctions into the control and measurement range, you must ensure that they are kept separate and laid as far apart as possible from power lines. If this is not possible, sheathed cable must be used.



### Warning – Danger of Electric Shock!

Work on the electrical equipment may be done only by qualified, authorized electricians.

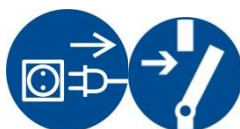

Make sure that the power switch is set to "0"!

Pull the power plug before you open the housing!

If the furnace has no power plug, cut off the power to the fixed connection.

## 18.1 Replacing a Controller



Fig. 11: Replacing a controller (similar to picture)

- Remove the 4 screws on the back side of the housing with a Phillips-tip screwdriver. Depending on the variant, these may be Phillips or Torx.
- Carefully pull the two parts of the housing apart.
- Undo the cable from the board by pressing the two orange colored elements on the plug and carefully removing it.
- You can now insert the plug on the board of the new controller.
- Screw the back of the housing on again.
- If a control module was also delivered, replace this too. Proceed as described in “Removing the Controller Modules”.

## 18.2 Removing the Controller Circuit Board

Controller boards may be installed and removed only by agreement with Nabertherm Service.

- Remove the cap of the jog dial with a flat-tip screwdriver.
- Loosen the fastening screw of the jog dial with a Phillips-tip screwdriver and then pull it off.
- Use a 10 mm socket to remove the nut holding the jog dial to the housing.
- Remove the 4 screws on the back side of the housing with a Phillips-tip screwdriver. Depending on the variant, these may be Phillips or Torx.



Fig. 12: Removing the controller circuit board - part 1 (similar to picture)

- Pull the two housing sections apart using moderate force.
- Remove the feed line of the circuit board by pressing the two orange clips on the connector and carefully pull it off.
- Remove the 7 screws holding the circuit board. Make sure that you do not damage the circuit board.
- Then you can separate the circuit board from the housing and replace it as necessary.



Fig. 13: Removing the controller circuit board - part 2 (similar to picture)

### 18.3 Installing the Controller Circuit Board

Controller boards may be installed and removed only by agreement with Nabertherm Service.

Front and back view of the circuit board.



Front



Back

Fig. 14: Installing the controller circuit board - part 1 (similar to picture)

- Carefully attach the circuit board to the front of the housing.
- Make sure that the circuit board rests on both of the locking mechanisms, above and below, provided for the purpose.
- Fasten the circuit board using the 7 fastening screws,
- Make sure that you do not damage the circuit board.
- Connect the feed line to the circuit board by carefully pushing on the green connector at the provided position so that it snaps in.
- Lead the feed line, as shown, through the housing.
- Carefully join the two parts of the housing.
- Make sure that the feed line is in the penetration.



Fig. 15: Installing the controller circuit board - part 2 (similar to picture)

- Use a screwdriver (Phillips) to screw the 4 screws on the back of the housing. Depending on the variant, they may be Phillips or Torx.
- With a 10 mm socket, slightly tighten the nut with which the operating knob is fixed to the housing.
- Insert the jog dial.

- Fix it in place with a screw using a screwdriver (Phillips).
- Carefully press the cover of the knob on with your thumb.



Fig. 16: Installing the controller circuit board - part 3 (similar to picture)

## 18.4 Removing the Controller Modules

- Disconnect the connections to the module by carefully pulling on the connector.
- To remove the module from the fastening bar, apply downward leverage with a flat-tip screwdriver to the red unlocking device.

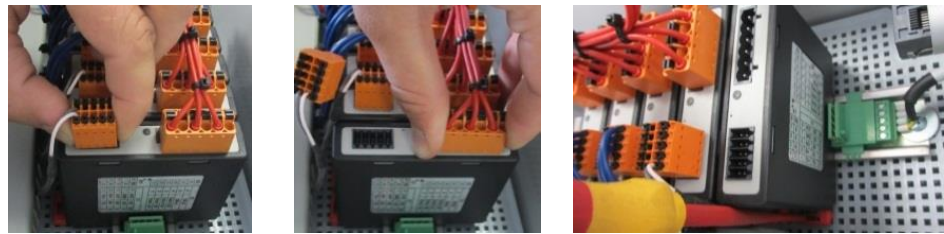

Fig. 17: Removing the controller module - part 1 (similar to picture)

At the same time, tilt the component carefully upwards. Then you can remove it from the switchgear.

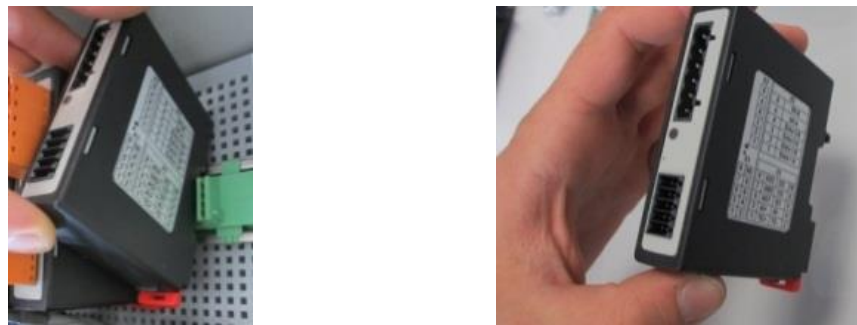

Fig. 18: Removing the controller module - part 2 (similar to picture)

## 18.5 Installing the Controller Module

- Hook the module into the fixing rail top first.
- Then tilt the module downward and allow it to engage.
- Carefully press the plug into the module. Make sure that the plug is pushed into the module as far as it can go. You feel the plug engaging. If not, increase the pressure.

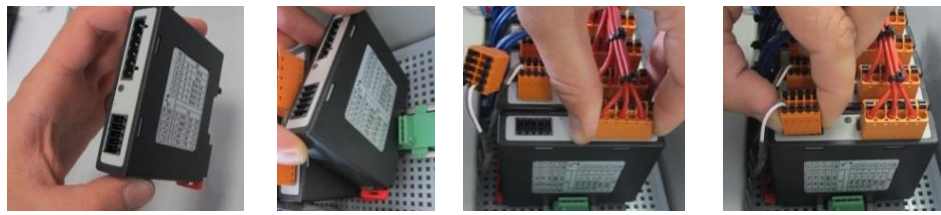

Fig. 19: Installing the controller module (similar to picture)

## 19 Electrical Connections

The following sample circuits illustrate different circuit variants. The final circuitry of the components is only permissible after having been checked by a qualified professional.

### 19.1 Controller Module

Every controller has at least one controller module in the switchgear. The controller consists of this controller module, together with the operating and display unit and a power adapter.

The overview shows the components:

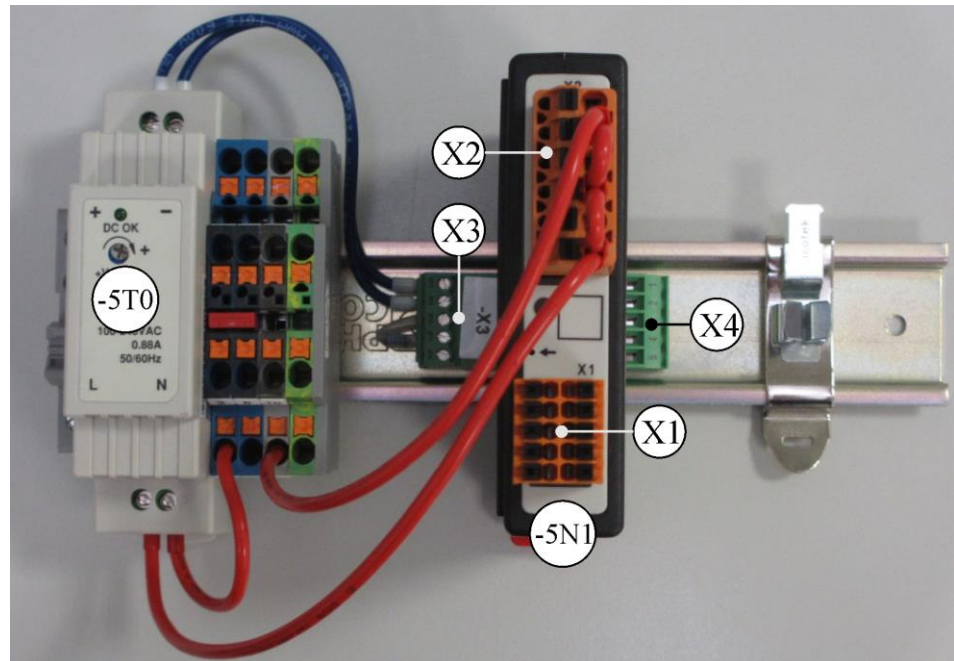

-5T0 = Power adapter

-5N1 = Controller module

Fig. 20: Power adapter and controller modules (similar to picture)

### 19.2 Power Line Requirements

For lines carrying mains voltage: Use 18 AWG or 1 mm<sup>2</sup> lines (multinorm line, 600 V, max. 105 °C, PVC insulation) and ferrules with insulation compliant with DIN 46228.

For lines carrying 12 V direct current: Use 20 AWG or 0.5 mm<sup>2</sup> (multinorm line, 600 V, max. 90 °C, brief periods 105 °C, PVC insulation) and ferrules with insulation compliant with DIN 46228.

### 19.3 General Connection

The following connection schematic includes all the possible wirings of the controller modules for single-zone furnaces.

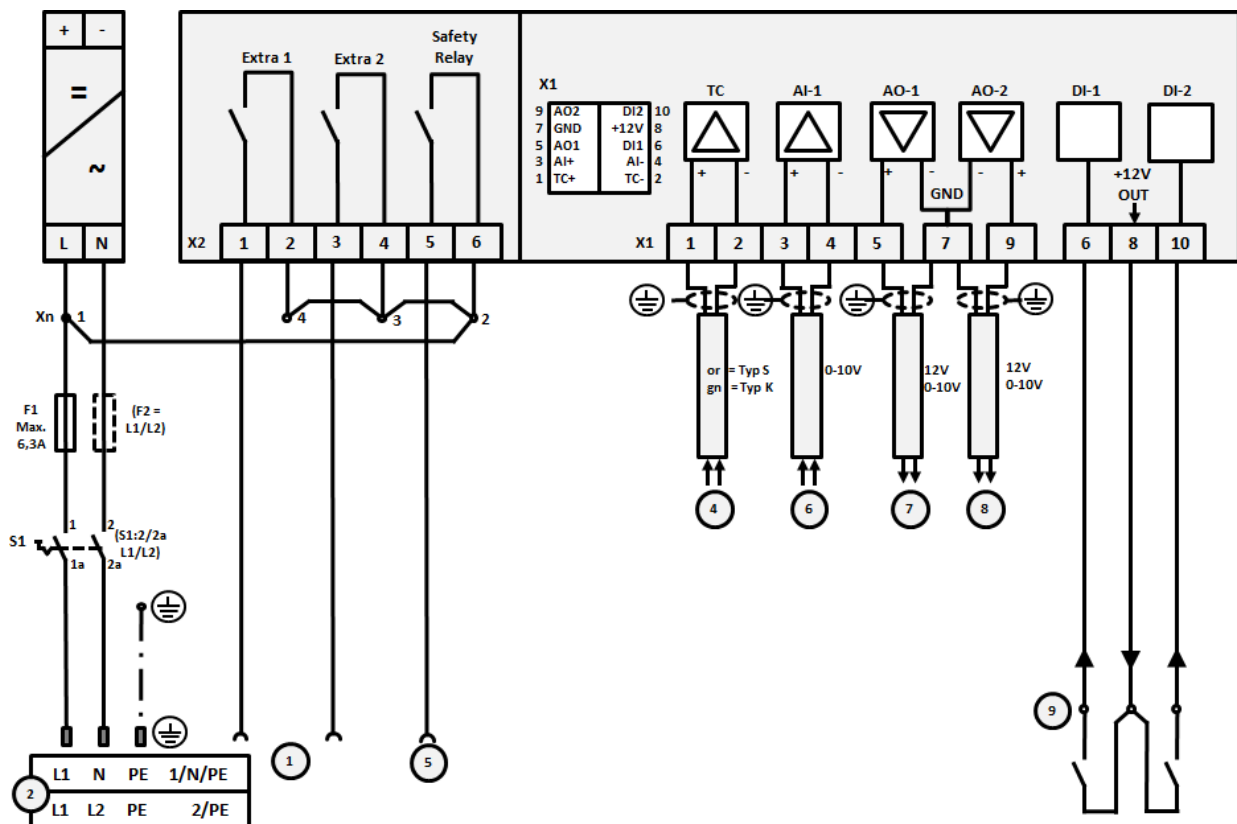

Fig. 21:

No.	Explanation
1	Outputs for extra functions
2	Power supply
3	-
4	Thermocouple connection
5	Output for safety relay
6	Analog input (0-10 V or 4-20 mA with load of 47 Ohm)
7	Analog Output 1 (Heating activation 12 V or 0-10 V contactor control via converter relay)
8	Analog output 2
9	Connections of potential-free contacts at Input 1 and 2

## 19.4 Furnaces up to 3.6 kW – Replacement for B130, B150, B180, C280, P330 to 12.2008

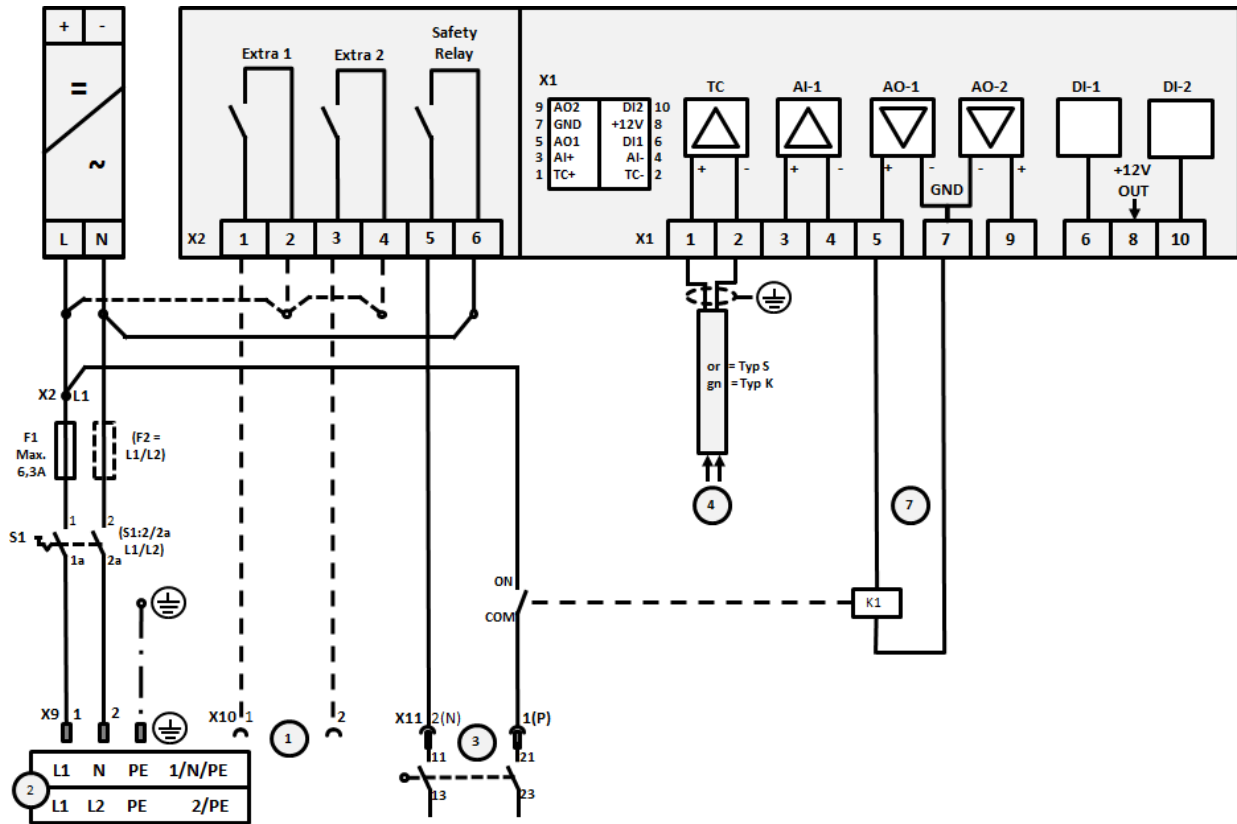

Fig. 22:

No.	Explanation
1	Outputs for extra functions (option)
2	Power supply
3	Connection of heating, see furnace operating manual
4	Thermocouple connection
5	-
6	-
7	Heating activation 12 V or 0-10 V contactor control via converter relay
8	-
9	-



**19.5 Furnaces up to 3.6 kW – Replacement for B130, B150, B180, C280, P330 from 01.2009**

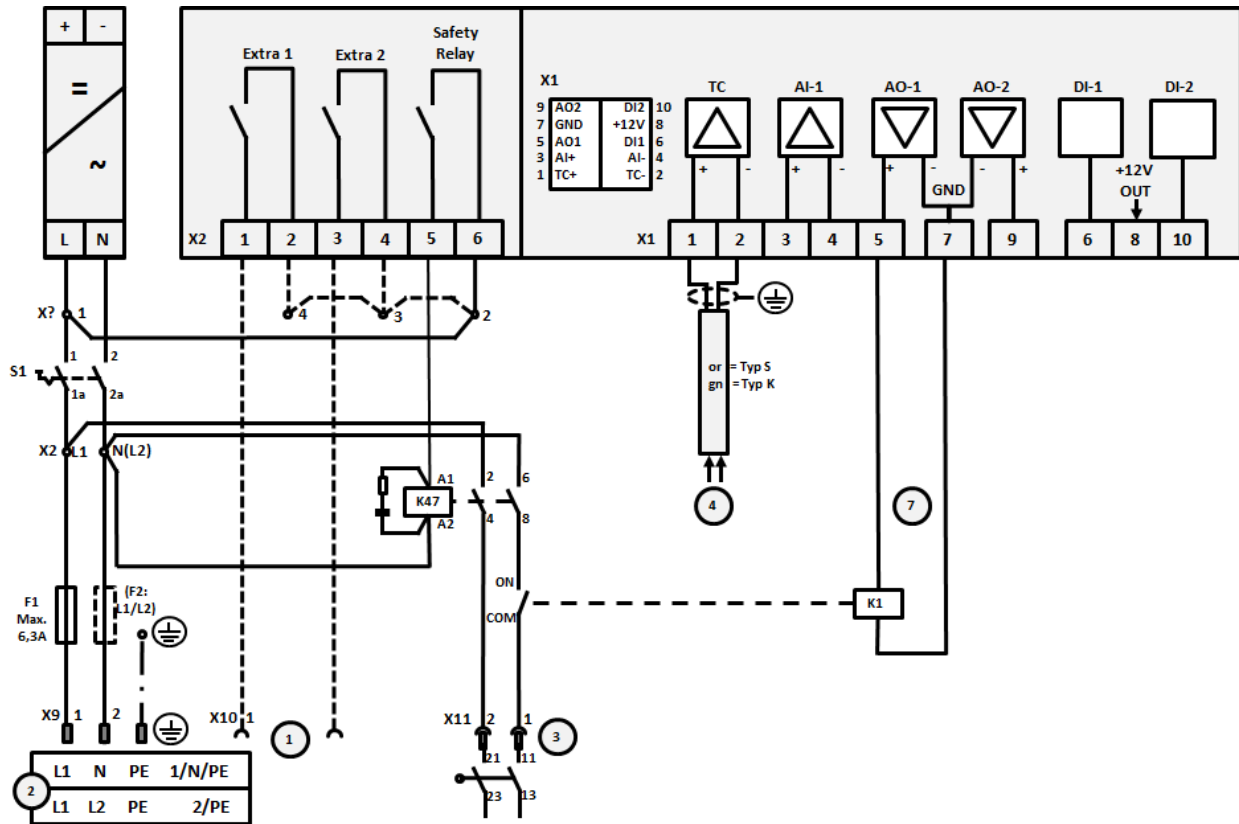

Fig. 23:

No.	Explanation
1	Outputs for extra functions (option)
2	Power supply
3	Connection of heating, see furnace operating manual
4	Thermocouple connection
5	-
6	-
7	Heating activation 12 V or 0-10 V contactor control via converter relay
8	-
9	-

## 19.6 Furnaces, Single-Zone > 3.6 kW with Semi-Conductor Relay or Protection

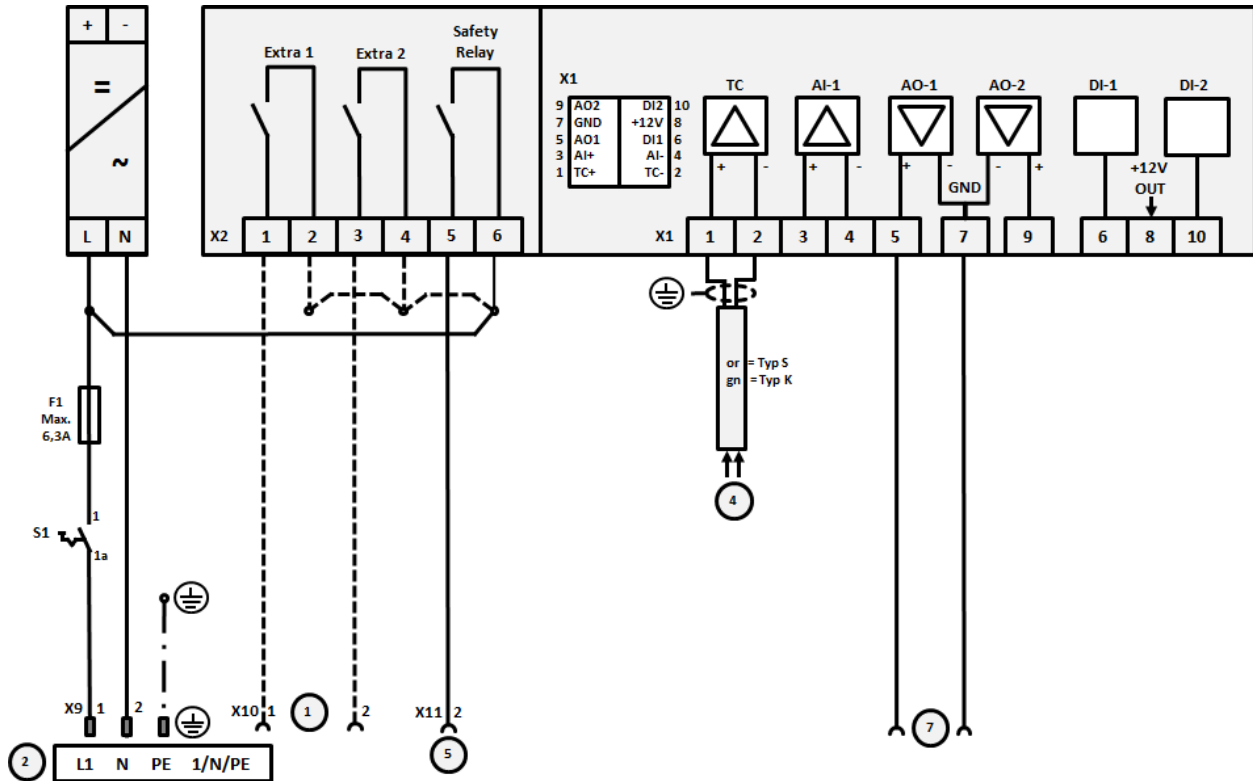

Fig. 24:

No.	Explanation
1	Outputs for extra functions (option)
2	Power supply
3	-
4	Thermocouple connection
5	Output for safety relay
6	-
7	Heating activation 12 V or 0-10 V contactor control via converter relay
8	-
9	-

### 19.7 Furnaces > 3.6 kW with 2 Heating Circuits

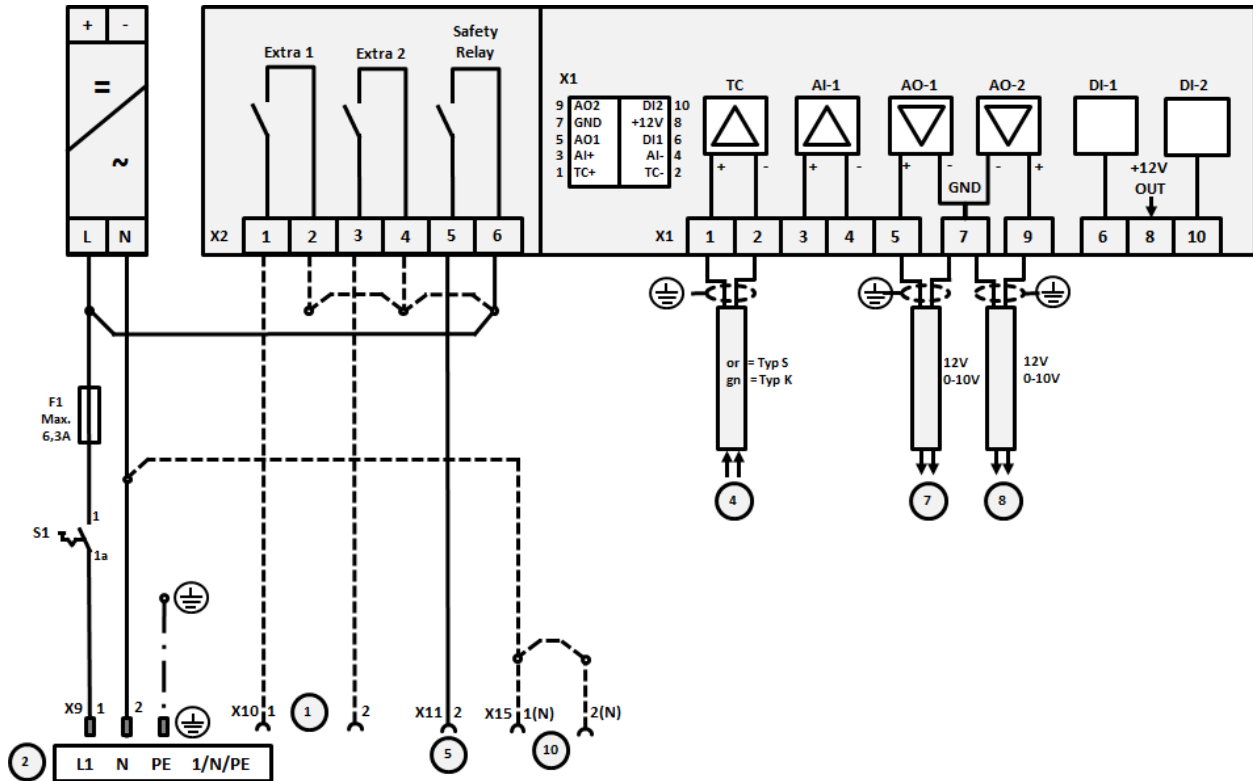

Fig. 25:

No.	Explanation
1	Outputs for extra functions
2	Power supply
3	-
4	Thermocouple connection
5	Output for safety relay
6	-
7	Heating activation 12 V or 0-10 V heating circuit 1 contactor control via converter relay
8	Heating activation 12 V or 0-10 V heating circuit 2 contactor control via converter relay
9	-

## 20 Nabertherm Service



The Nabertherm Service team is available at all times for furnace maintenance and repair. If you have any questions, problems, or requirements, contact Nabertherm GmbH. By mail, phone, or the Internet.

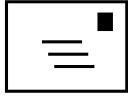

### Mail

Nabertherm GmbH  
Bahnhofstrasse 20  
28865 Lilienthal/Germany



### Phone or fax

Phone: +49 (4298) 922-0  
Fax: +49 (4298) 922-129



### Web or e-mail

[www.nabertherm.com](http://www.nabertherm.com)  
[contact@nabertherm.de](mailto:contact@nabertherm.de)

**When you contact us, please have the type plate details of the furnace or controller at hand.**

Provide the following details from the type plate:

<b>Nabertherm</b> <small>MORE THAN HEAT 33-3000 °C</small>		
Nabertherm GmbH Bahnhofstr. 20, 28865 Lilienthal/Bremen ,Germany Tel +49 (04298) 922-0, Fax +49 (04298) 922-129 contact@nabertherm.de  <small>www.nabertherm.com</small>		
①	②	④
③		
<b>CE</b>		

- ① Furnace model
- ② Serial number
- ③ Article number
- ④ Year of construction

Fig. 26: Example (type plate)







